



PORSCHE



Cayman GT4

Owner's Manual

Dr. Ing. h.c. F. Porsche AG is the owner of numerous trademarks, both registered and unregistered, including without limitation the Porsche Crest®, Porsche®, Boxster®, Carrera®, Cayenne®, Cayman®, Panamera®, Macan®, Speedster®, Tiptronic®, Equipment®, VarioCam®, PCM™, PDK®, 911™, 4S®, RS® and the model numbers and the distinctive shapes of the Porsche automobiles such as, the federally registered 911 and Boxster automobiles in the US. The third party trademarks contained herein are the properties of their respective owners.

Porsche Cars North America, Inc. and its affiliates believes the specifications to be correct at the time of printing. However, specifications, standard equipment and options are subject to change without notice. Some options may be unavailable when a car is built. Some vehicles may be shown with equipment that is not available in the US and Canada. Please ask your authorized dealer for advice concerning the current availability of options and verify the optional equipment that you ordered.

Porsche recommends safety belt usage and observance of traffic laws at all times.

© 2014 Dr. Ing. h.c. F. Porsche AG

Orientation guides in the Owner's Manual

The orientation guides in the Owner's Manual are highlighted in yellow.

Overall Table of Contents

At the start of the Owner's Manual you will find an overview of the overall contents of the Owner's Manual.

Section Contents

There is a summary of topics with the corresponding page numbers at the beginning of each main chapter.

Index

There is a detailed, alphabetical index at the end of this Owner's Manual.

Safety instructions in the Owner's Manual

For your own protection and longer service life of your car, please heed all operating instructions and special warnings. These special warnings contain important messages regarding your safety and/or the potential for damage to your Porsche. Ignoring them could result in serious mechanical failure, serious personal injury or death.

Various types of safety instructions are used in this Owner's Manual.



DANGER

Serious injury or death

Failure to observe safety instructions in the "Danger" category will result in serious injury or death.



WARNING

Possible serious injury or death

Failure to observe safety instructions in the "Warning" category could result in serious injury or death.



CAUTION

Possible moderate or minor injury

Failure to observe safety instructions in the "Caution" category can result in moderate or minor injury.

NOTICE

Possible vehicle damage

Failure to observe safety instructions in the "Notice" category could result in damage to the vehicle.



Information

Additional information, tips and instructions are indicated by the word "Information". Please read this information carefully and follow the instructions.

Dear Owner,

Thank you for choosing a Porsche sports car. No other car embodies such a unique blend of legendary heritage and cutting edge innovation. For maximum safety and pleasure, we encourage you to read the Owner's Manual and take time to familiarize yourself with the operation of your Porsche vehicle before you drive it. Always drive within your own unique capabilities as a driver and ensure that anyone else driving your Porsche vehicle does the same. To help prevent or minimize injury, always use your safety belts and always lawfully operate your Porsche vehicle. Always keep your Owner's Manual in the car. If you sell your Porsche vehicle, pass the Owner's Manual and other operation manuals on to the new owner.

Should you have any questions regarding the operation or maintenance of your vehicle, please call 1-800-PORSCHE or contact your authorized Porsche dealership.

A separate Maintenance Booklet explains how you can keep your Porsche in top driving condition by having it serviced regularly.

A separate Warranty and Customer Information Booklet contains detailed information about the warranties covering your Porsche.

For U.S. only:

If you believe that your vehicle has a fault which could cause a crash, injury or death, you should immediately inform the National Highway Traffic Safety Administration (NHTSA) in addition to notifying Porsche Cars North America, Inc. (Porsche Cars N.A.).

If NHTSA receives similar complaints, it may open an investigation, and if it finds that a safety problem exists in a group of vehicles, it may order a recall and remedy campaign. However, NHTSA cannot become involved in individual problems between you and your dealer, or Porsche Cars N.A..

To contact NHTSA, you may call the Vehicle Safety Hotline toll-free at

1-888-327-4236 (TTY: 1-800-424-9153);

go to

<http://www.safercar.gov>;

or write to:

Administrator, NHTSA, 1200 New Jersey Ave, SE, Washington, DC 20590.

You can also obtain other information about motor vehicle safety from <http://www.safercar.gov>.

Your car has thousands of parts and components which have been designed and manufactured in accordance with Porsche's high standards of engineering quality and safety.

WARNING

Alteration or misuse of vehicle

Any alteration of the vehicle may negate or interfere with those safety features built into the vehicle. Modifications may be carried out on your vehicle only if approved by Porsche.

Your Porsche is intended to be used in a safe manner obeying the local traffic laws and in the light of driving conditions faced by you, and in accordance with the instructions provided in this Owner's Manual.

- ▷ Do not misuse your Porsche by ignoring those laws and driving conditions, or by ignoring the instructions in this manual.
 - ▷ Do not alter your Porsche. Any alteration could create dangerous conditions or defeat safety engineering features built into your car.
-

NOTICE

Risk of damage to the engine due to inadequate supply of oil.

The fitting of racing tires (e.g. slicks) for sporting events is not approved by Porsche. Very high cornering speeds can be achieved with racing tires. However, the resulting transverse acceleration values would jeopardize the adequate supply of oil to the engine. Porsche therefore will not accept any warranty or accept any liability for damage occurring as a result of non-compliance with this provision.

- ▷ Do not fit racing tires (e.g. slicks) for sporting events on your vehicle.
-

Regularly check your vehicle for signs of damage.

Damaged or missing aerodynamic components such as spoilers or underside panels affect the driving behavior and therefore must be replaced immediately.

Your car may have all or some of the components described in this manual.

Should you have difficulty understanding any of the explanations of features or equipment installed in your vehicle, contact your authorized Porsche dealer. He/She will be glad to assist you. Also check with your dealer on other available options or equipment.

Throughout this booklet, left is designated as the driver's side of the vehicle, and right as the passenger's side of the vehicle.

Text, illustrations and specifications in this manual are based on the information available at the time of printing.

It has always been Porsche's policy to continuously improve its products. Porsche, therefore, reserves the right to make changes in design and specification, and to make additions or improvements in its product without incurring any obligation to install them on products previously manufactured.

We wish you many miles of safe and pleasurable driving in your Porsche.

Note to owners

In Canada, this manual is also available in French. To obtain a copy contact your dealer or write to:

Note aux propriétaires

Au Canada on peut se procurer un exemplaire de ce Manuel en français auprès du concessionnaire ou du:

Porsche Cars Canada, Ltd.
Automobiles Porsche Canada, LTEE

5925 Airport Road
Suite 420
Mississauga, Ontario
Canada, L4V 1W1

Telephone number for customer assistance:
1-800-PORSCHE / Option 3

Development Philosophy

Porsche Cayman GT4 stands for a sports car with exceptional performance, both on the road and on the race circuit. This objective means that, in the event of any compromise being required between sportiness and comfort during the development process, the tendency will be geared more towards sportiness. This can result in the following restrictions in comfort:

- Brake squeal when light pressure applied to the pedal shortly before stopping.
- Cracking noise in area of front-axle coil springs.
- Aerodynamic-related extremely low vehicle position with restrictions in terms of ground clearance.

Sport tires

Your vehicle is equipped with special sport tires (ultra high performance tires). This type of tire is approved for use on public highways and comply with all statutory requirements and safety criteria. The design of the tire is also geared towards use on racing circuits (driver safety training courses, sports driving schools, Club Sport events) and provides distinct advantages here in terms of dry grip and wear compared to conventional road tires.

The major features are a reduced tread depth and a special tread pattern and carcass.

The design features of this sports tire result in the following effects compared with other summer tires when used under normal driving conditions:

- Sport tires have a smaller tread depth, and thus can reach their wear limit sooner. As with all tires, the attainable mileage depends on the individual driving style and the conditions of use.
- Exercise caution when driving on wet roads, paying special attention to hydroplaning situations (stagnant water, puddles, lane grooves). Sport tires have a lower tread depth than normal tires and you must therefore adapt speed accordingly when driving on wet surfaces.
- The driver's skill level must be commensurate with the vehicle performance levels in the upper range limits, due to increased safety risks in the upper range limits.

- ▷ Sport tires are not suitable for use in cold, snowy, or icy conditions. At outside temperatures below 45 °F (7 °C) change to snow tires.
- ▷ Notify anyone using your car of these characteristics and possible effects.

DANGER

Loss of Road Surface Contact, Control over the Vehicle and Braking Ability

The reduced tire tread depth means that there is an increased risk of aquaplaning on wet roads.

- ▷ When driving on wet or mud-covered roads reduce speed significantly.

DANGER

Worn Tires

Sport tires have a smaller tread depth, and thus can reach their wear limit sooner. It is important to check tire wear frequently to avoid risk of serious personal injury or death from worn tires.

- ▷ Check tire wear frequently.

Driving on Race Circuit (e.g. sports driving schools, motor sport events)

Brake fluid, brake pads and brake disks

Brake fluid absorbs moisture from the air over time. This accumulation of water lowers the boiling point and can impair braking action if the brakes are subjected to high temperatures, such as can occur on race circuits (sports driving school, motor sport events).

The brake fluid should therefore not be more than 12 months old if the vehicle is driven on race circuits (sports driving school, motor sport events).

- ▷ For more information, see the "Maintenance" booklet.

Wear on the brake pads and brake disks depends to a great extent on the driving style and driving conditions. Wear on the brake components is increased as a result of high temperatures, such as can occur on race circuits (sports driving school, motor sport events).

- ▷ Before and after driving on race circuits (sports driving school, motor sport events), it is important therefore to carry out a visual inspection of the brake pads and brake disks for wear.

Racing tires

The fitting of racing tires (e.g. slicks) for sporting events is not approved by Porsche.

Very high cornering speeds can be achieved with racing tires. The resulting transverse acceleration values would jeopardise the adequate supply of oil to the engine.

Porsche therefore refuses to accept any warranty or liability for damage occurring as a result of non-compliance with this provision.

Setting and operating vehicle components when driving

WARNING

Operating components while driving

Setting or operating the multi-function display, radio, navigation system, telephone or other equipment when driving could distract you from the traffic. You could lose control of the vehicle resulting in serious personal injury or death.

- ▷ Operate the components while driving only if the traffic situation allows you to do so safely.
 - ▷ Carry out any complicated operating or setting procedures only with the vehicle stationary.
-

Engine Exhaust

DANGER

Engine exhaust inhalation

Engine exhaust is dangerous if inhaled. Engine exhaust fumes have many components which you can smell. They also contain carbon monoxide (CO), which is a colorless and odorless gas.

Carbon monoxide can cause unconsciousness and even death if inhaled.

- ▷ Never start or let the engine run in an enclosed, unventilated area.
It is not recommended to sit in your car for prolonged periods with the engine on and the car not moving.
-

WARNING

California
Proposition 65

Engine exhaust, some of its constituents, and certain vehicle components contain or emit chemicals known to the State of California to cause cancer and birth defects or other reproductive harm.

In addition, certain fluids contained in vehicles and certain products of component wear contain or emit chemicals known to the State of California to cause cancer and birth defects or other reproductive harm.

Hot Exhaust Pipes

WARNING

Hot exhaust pipes

The exhaust pipe is hot when the vehicle is running and remains hot for some time after the vehicle is turned off.

- ▷ To prevent injury, make a point of noting where your vehicle's exhaust pipe is, avoid placing your legs near the exhaust pipe, and closely supervise children around the vehicle during time when the exhaust pipe could be hot.
A hot exhaust pipe can cause serious burns.
-

Portable Fuel Containers

DANGER

Portable fuel container leaks

Portable fuel containers may leak, whether they are full or partially empty. Fuel leaking from a portable container carried in your vehicle could, in case of an accident, cause a fire or explosion.

- ▷ Never carry additional fuel in portable containers in your vehicle.
-

Ground Clearance

NOTICE

Risk of damage to the vehicle due to lower ground clearance.

The vehicle may touch the ground as a result of reduced ground clearance.

- ▷ Drive carefully and slowly on steep slopes (e. g. parking lots, curbs, uneven roads, lifting platforms etc.).
 - ▷ Avoid steep ramps.
-

Porsche Ceramic Composite Brake (PCCB)

- ▷ Please see the chapter "BRAKES" on page 121.

The high-performance brake system is designed for optimal braking effect at all speeds and temperatures.

Certain speeds, braking forces and ambient conditions (such as temperature and humidity) therefore might cause brake noises.

Wear on the different components and braking system, such as brake pads and brake disks, depends to a great extent on the individual driving style and the conditions of use and therefore cannot be expressed in actual miles on the road.

The values communicated by Porsche are based on normal operation adapted to traffic. Wear increases considerably when the vehicle is driven on race tracks or through an aggressive driving style.

- ▷ Please consult an authorized Porsche dealer about the current guidelines in effect before such use of your vehicle.

Service Brake

- ▷ Please see the chapter “BRAKES” on page 120.

Both the standard brake system with composite brake disks and the Porsche Ceramic Composite Brake (PCCB) are high-performance brake systems, designed specifically for driving on race circuits.

Certain speeds, braking forces and ambient conditions (such as temperature and humidity) may therefore cause the brakes to squeal. This also applies after completion of the running-in phase required for the new brake components.

Wear on different components of the brake system, e.g. brake pads or brake disks, depends to a great extent on the individual driving style and the conditions of use and therefore cannot be expressed in actual miles on the road.

The values communicated by Porsche are based on normal operation adapted to traffic. Wear increases considerably when the vehicle is driven on race tracks or as a result of aggressive driving. Before driving your vehicle in this way, please ask your authorized Porsche dealer about the guidelines that currently apply.

Dear Porsche Owner,

A lot has gone into the manufacture of your Porsche sports car, including advanced engineering, rigid quality control and demanding inspections. These engineering and safety features will be enhanced by you...

the safe driver...

- who knows her/his car and all controls,
- who maintains the vehicle properly,
- who uses driving skills wisely and always drives within her/his own capabilities and the level of familiarity with the vehicle.

You will find helpful hints in this manual on how to perform most of the checks listed on the following pages. If in doubt, have these checks performed by your authorized Porsche dealer.

Before driving off...

Check the following items first

- ▷ Turn the engine off before you attempt any checks or repairs on the vehicle.
- ▷ Be sure the tires are inflated correctly. Check tires for damage and tire wear.
- ▷ See that wheel bolts are properly tightened and not loose or missing.
- ▷ Check engine oil level, add if necessary. Make it a habit to check the engine oil with every refueling.
- ▷ Check all fluid levels such as windshield washer and brake fluid levels.

- ▷ Be sure the vehicle battery is well charged and cranks the engine properly.
- ▷ Check all doors and lids for proper operation and latch them properly.
- ▷ Check and if necessary replace worn or cracked wiper blades.
- ▷ See that all windows are clear and unobstructed.
- ▷ Check air intake slots and area between luggage compartment lid and windshield. Ensure that these areas are free of snow and ice, so the heater and the windshield wipers work properly.
- ▷ If a child will be riding in the vehicle, check child seat/child seat restraint system to ensure that restraints are properly adjusted.
- ▷ Check all exterior and interior lights for operation and that the lenses are clean.
- ▷ Check the headlights for proper aim, and if necessary, have them adjusted.
- ▷ Check under the vehicle for leaks.
- ▷ Be sure all luggage is stowed securely.

Emergency equipment

It is good practice to carry emergency equipment in your vehicle.

Some of the items you should have are: window scraper, snow brush, container or bag of sand or salt, emergency light, small shovel, first-aid kit, etc.

In the driver's seat...

- ▷ Check operation of the horn.
- ▷ Position seat for easy reach of foot pedals and controls. To reduce the possibility of injury from the air bag deployment, you should always sit back as far from the steering wheel as is practical, while still maintaining full vehicle control.
- ▷ Adjust the inside and outside rear view mirrors.
- ▷ Buckle your safety belts.
- ▷ Check operation of the foot and electric parking brake.
- ▷ Check all warning and indicator lights with ignition on and engine not running.
- ▷ Start engine and check all warning displays for warning symbols.
- ▷ Never leave an idling car unattended.
- ▷ Lock doors from inside, especially with children in the car to prevent inadvertent opening of doors from inside or outside. Drive with doors locked.

On the road...

- ▷ Never drive after you have consumed alcohol or drugs.
- ▷ Always have your safety belt fastened.
- ▷ Always drive defensively. Expect the unexpected.
- ▷ Use signals to indicate turns and lane changes.
- ▷ Turn on headlights at dusk or when the driving conditions warrant it.
- ▷ Always keep a safe distance from the vehicle in front of you, depending on traffic, road and weather conditions.
- ▷ Reduce speed at night and during inclement weather.
Driving in wet weather requires caution and reduced speeds, particularly on roads with standing water, as the handling characteristics of the vehicle may be impaired due to hydroplaning of the tires.
- ▷ Always observe speed limits and obey road signs and traffic laws.
- ▷ When tired, get well off the road, stop and take a rest. Turn the engine off. Do not sit in the vehicle with engine idling. Please see the chapter "ENGINE EXHAUST" on page 4.
- ▷ When parked, always put the electric parking brake on.
On hills also turn the front wheels toward the curb.
- ▷ When emergency repairs become necessary, move the vehicle well off the road. Turn on the emergency flasher and use other warning devices to alert other motorists. Do not park or operate the vehicle in areas where the hot exhaust system may come in contact with dry grass, brush, spilled fuel or other flammable material.

- ▷ Make it a habit to check the engine oil with every refueling.

While driving



Information

Fuel consumption and CO₂ emissions can be reduced through correct use and regular servicing of the vehicle, as well as by an appropriate driving style, e.g. defensive driving style, low speeds, anticipatory braking actions, correct tire pressure, no unnecessary engine idling, and no unnecessary ballast.

Break in hints for the first 2,000 miles (3,000 kilometers)

The following tips will be helpful in obtaining optimum performance from your new Porsche.

Despite the most modern, high-precision manufacturing methods, the moving parts must still wear in with each other. This wearing-in occurs mainly in the first 2,000 miles (3,000 km).

Therefore:

- ▷ Preferably take longer trips.
- ▷ Avoid frequent cold starts with short-distance driving whenever possible.
- ▷ Avoid full throttle starts and abrupt stops.
- ▷ Do not exceed maximum engine speed of 4,200 rpm (revolutions per minute).
- ▷ Do not run a cold engine at high rpm either in Neutral or in gear.
- ▷ Do not let the engine labor, especially when driving uphill. Shift to the next lower gear in time (use the most favorable rpm range).
- ▷ Never lug the engine in high gear at low speeds. This rule applies at all times, not just during the break-in period.
- ▷ Do not participate in motor racing events, sports driving schools, etc. during the first 2,000 miles (3,000 kilometers).

There may be a slight stiffness in the steering, gear-shifting or other controls during the break-in period which will gradually disappear.

Break in brake pads and brake disks

New brake pads and disks have to be "broken in", and therefore only attain optimal friction when the car has covered several hundred miles or km.

The slightly reduced braking ability must be compensated for by pressing the brake pedal harder. This also applies whenever the brake pads and brake disks are replaced.

New tires

New tires do not have maximum traction. They tend to be slippery.

- ▷ Break in new tires by driving at moderate speeds during the first 60 to 120 miles (100 to 200 km). Longer braking distances must be anticipated.

Engine oil and fuel consumption

During the break-in period oil and fuel consumption may be higher than normal.

As always, the rate of oil consumption depends on the quality and viscosity of oil, the speed at which the engine is operated, the climate and road conditions, as well as the amount of dilution and oxidation of the lubricant.

- ▷ Make a habit of checking engine oil with every refueling, add if necessary.

Contents

Dear Owner	1	Opening and Closing Luggage		Instrument Lighting	66
Development Philosophy	2	Compartment Lids	24	Turn Signal/High Beam/Headlight	
Sport tires	3	Malfuncions when Opening and Closing	26	Flasher Stalk/Parking Light Switch	66
Driving on Race Circuit (e.g. Sports Driving		Trunk Entrapment	29	Emergency Flasher	67
Schools, Club Sport Events)	3			Interior/Reading Lights	67
Setting and operating vehicle components		Seats, Mirrors and Steering Wheel	30	Brief Overview – Windshield wipers	69
when driving	4	Seat Adjustment and Head Restraints	31	Windshield Wiper/Washer Stalk	70
Engine Exhaust	4	Seats	31		
Portable Fuel Containers	4	Seat Heating	33	Instrument Panel and	
Ground Clearance	4	Safety Belts	33	Multi-Function Display	73
Porsche Ceramic Composite Brake (PCCB)	4	Airbag Systems	35	Instrument Panel USA Models	74
Service Brake	5	Child Restraint Systems	39	Instrument Panel Canada Models	75
Dear Porsche Owner	5	Top Tether	43	Displays on the Instrument Panel	76
Before driving off	5	Exterior Mirrors	44	Battery/Alternator	77
In the driver's seat	6	Interior Mirror	45	Check Engine	
On the road	6	Steering Wheel Adjustment	46	(Emission Control)	77
Break in hints for the first 2,000 miles		Sun Visors	47	Acoustic Signals	77
(3,000 kilometers)	7	Vanity Mirror	47	Operating the Multi-Function Display on the	
				Instrument Panel	78
Overview Illustrations	10	Air Conditioning	48	Vehicle Menu	81
Driver's Cockpit	11	Heating and Ventilation	49	Audio Menu	83
Steering Wheel and Instrument Panel	12	Manual Air Conditioning	51	Phone Menu	84
Center Console	13	Automatically Controlled 2-zone Air		Map Menu	84
Control Panel	14	Conditioning	54	Navigation Menu	85
Overhead Console	15	Air Vents	59	Trip Menu	86
		Heated Rear Window/		Tire Pressure Menu (Tire Pressure	
Opening and Locking	16	Exterior Mirror Heating	59	Monitoring System, TPMS)	86
Never invite car theft!	17			Chrono Menu (Stopwatch)	95
Notes on the Key and Central Locking		Windows	60	Gear Shift Assist Menu	97
System	18	Power Windows	61	G-Forces Menu	98
Central Locking System	19			Performance Menu	98
Brief Overview – Opening and Locking from		Lights, Turn Signals and Windshield		Vehicle Settings on the	
Outside	20	Wipers	63	Multi-Function Display	99
Opening and Locking from Outside	21	Light Switch	64	Overview of Warning and Information	
Opening and Locking from Inside	23			Messages	109

Driving and Driving Safety	117	Parking	153	Tires and Wheels	186
Diagnostic Socket	118	Garage Door Opener HomeLink® (Universal Remote Control).....	154	Changing Wheels	196
Ignition Lock	118			Wheel Attachment Faces	198
Starting and Stopping the Engine	119	Alarm System and Theft Protection ..	158	Wheel Bolts	199
Electric Parking Brake	120	Alarm System and Passenger Compartment		Flat Tire	199
Brakes	121	Monitoring	159	Electrical System	201
Cruise Control	124	Immobilizer	160	Battery (12 volt)	205
Car Audio Operation/Tips	126	Theft Protection	160	External Power Supply, Emergency starting with jumper cables	207
Porsche Communication Management (PCM)	128			Changing Car Key (Remote Control) Battery .	209
USB/iPod® and AUX	128	Maintenance and Car Care.....	161	Replacing bulbs.....	210
Voice Control.....	129	Exercise Extreme Caution when Working on your vehicle	162	Headlights	210
Porsche Track Precision App	129	Engine Oil	165	Headlight Adjustment.....	212
Lap Trigger	130	Checking Engine Oil Level	165	Towing	214
Manual Transmission, Clutch.....	132	Topping up Engine Oil.....	166	Fire extinguisher.....	216
Transmission and Chassis Control Systems .	134	Washer Fluid	167		
Porsche Stability Management (PSM).....	135	Wiper Blades	168	Tire Pressure and Technical Data	217
ABS Brake System		Emission Control System	168	Vehicle Identification Data	218
(Anti-Lock Brake System).....	138	How Emission Control Works	169	Engine Data	219
Porsche Active Suspension Management (PASM).....	139	Fuel Economy	170	Wheels, Tires	220
Porsche Torque Vectoring (PTV) Functional Description.....	140	Operating Your Porsche in other Countries....	170	Tire Pressure for Cold Tires (68 °F/ 20 °C) ..	221
Dynamic Engine Mounting (PADM)	140	Fuel	171	Weights	222
“Sport” mode	141	Portable Fuel Container	173	Filling Capacities	223
Sports Exhaust System	141	Fuel Recommendations	173	Driving Performance.....	224
		Fuel Evaporation Control	174	Chassis Setup.....	224
		Car Care Instructions	174	Engine Diagram at Full Load.....	225
Storage and Luggage Compartment..	142				
Storage	143	Minor Repairs.....	181	Index	226
Drinks Holder/Cupholder	144	Exercise Extreme Caution when Working on your vehicle	182		
Ashtray	146	Checking the Coolant Level and Adding Coolant	184		
Cigarette Lighter.....	146	Brake Fluid	185		
Sockets	147	Electromechanical Power Steering	186		
Front Luggage Compartment.....	148	Changing Air Cleaner	186		
Rear Luggage Compartment.....	150	Changing Particle Filters	186		
Luggage Cover	150				
Loading Information	151				

Overview Illustrations

Driver's Cockpit	11
Steering Wheel and Instrument Panel	12
Center Console	13
Control Panel	14
Overhead Console	15

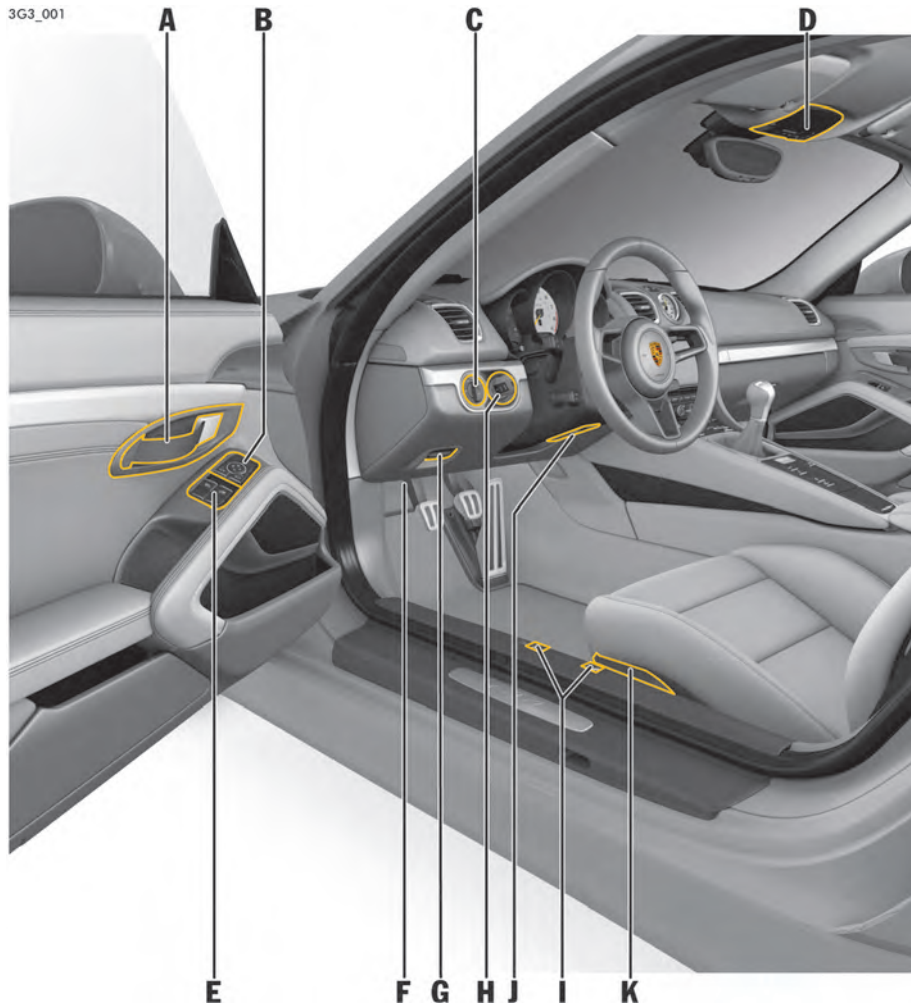

Driver's Cockpit

- A** Door opener
See page 24.
- B** Exterior-mirror setting
See page 44.
- C** Light switch
See page 64.
- D** Overhead operating console
See page 154.
- E** Power windows
See page 61.
- F** Diagnostic socket (OBD)
See page 118.
- G** Electric parking brake
See page 120.
- H** Ignition lock
See page 118.
- I** Front and rear lid release
See page 24.
- J** Steering wheel adjustment
See page 46.
- K** Seat adjustment
See page 31.



Steering Wheel and Instrument Panel

- A** Turn signal lights
See page 66.
- B** Speedometer
See page 76.
Warning and indicator lights
See page 74.
- C** Tachometer
See page 76.
Warning and indicator lights
See page 74.
- D** Multi-function display
See page 76.
Warning and information messages
See page 109.
- E** Windshield wipers
See page 69.
- F** Cruise control
See page 124.
- G** Horn
- H** Telephone controls, multi-function display
See page 78.

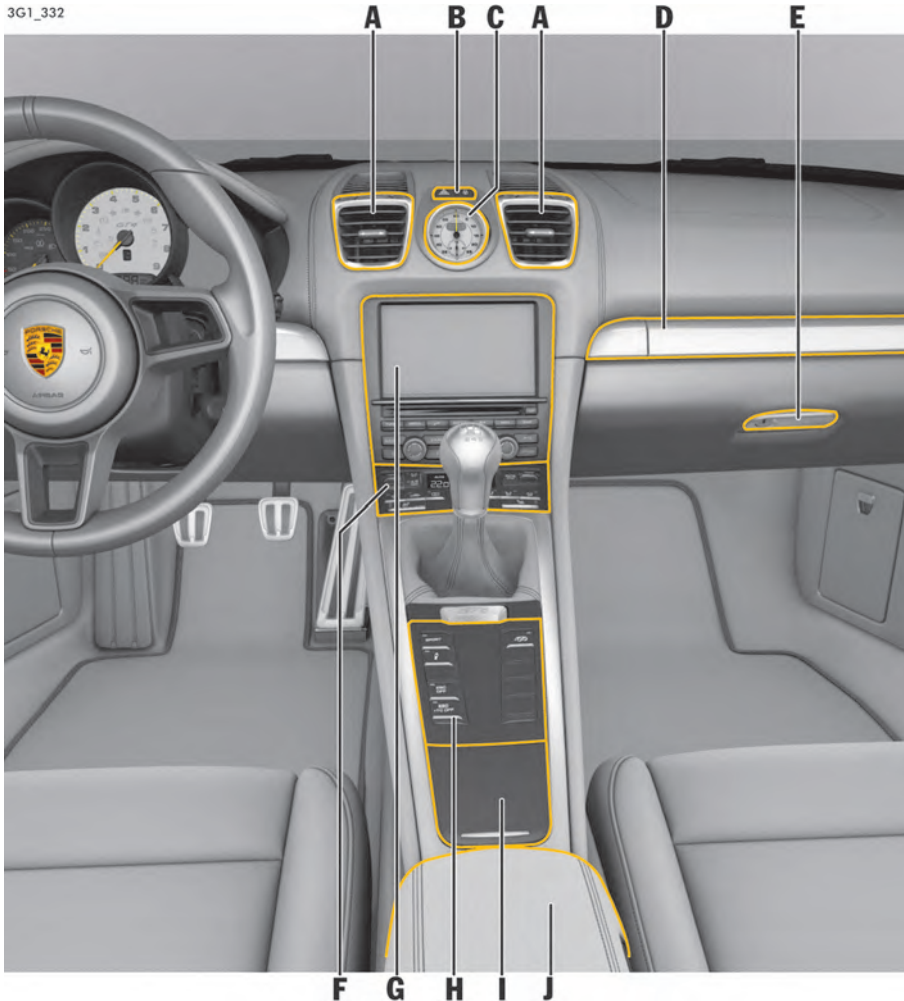

Center Console

- A** Air vents
See page 59.
- B** Emergency flasher switch
See page 67.
Central locking button
See page 22.
- C** Sport Chrono clock
See page 95.
- D** Drinks holder/cupholder
See page 144.
- E** Glove box
See page 143.
- F** Operating panel for air conditioning
See page 51.
- G** Porsche Communication Management (PCM)
See page 128.
- H** Control panel
See page 14.
- I** Ashtray, cigarette lighter, storage tray
See page 146.
- J** Storage tray
See page 144.

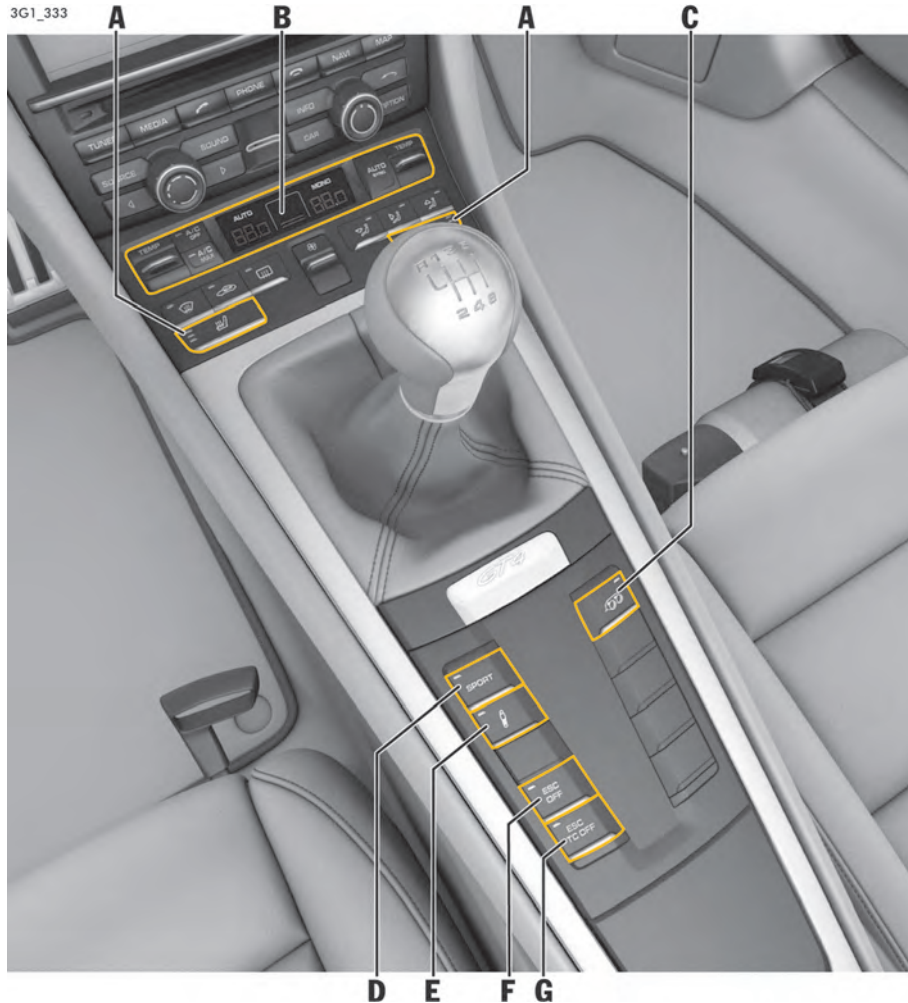

Control Panel

- A** Heated seats/seat ventilation
See page 33.
- B** Control panel for air conditioning
See page 51.
- C** Sports exhaust system
See page 141.
- D** "Sport" mode
See page 141.
- E** Porsche Active Suspension Management (PASM)
See page 139.
- F** Electronic Stability Control (ESC)
See page 137.
- G** Electronic Stability Control (ESC) und Traction Control (TC)
See page 137.

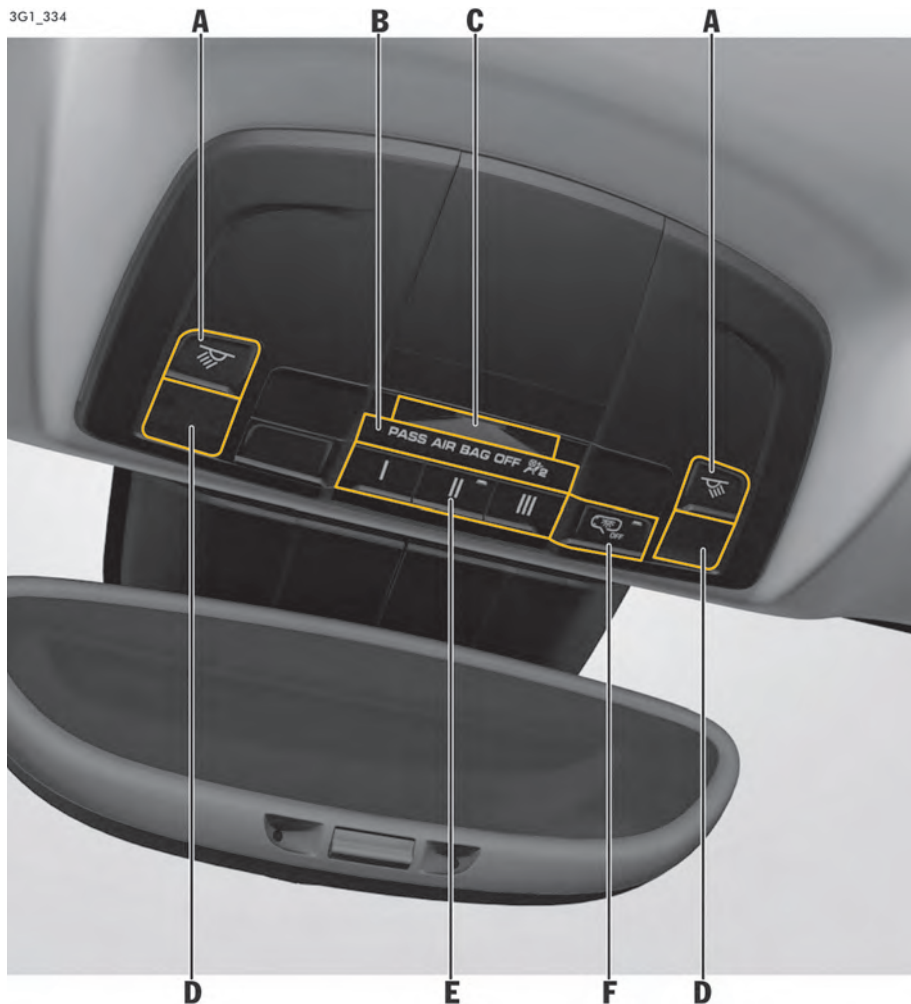

Overhead Console

- A** Button for interior/reading lights
See page 67.
- B** PASS AIR BAG OFF warning light
See page 38.
- C** Interior light
See page 67.
- D** Reading lights
See page 67.
- E** Garage door opener (HomeLink®)
See page 154.
- F** Button for interior/reading lights
See page 68.

Opening and Locking

Never invite car theft!	17
Notes on the Key and Central Locking System	18
Central Locking System	19
Brief Overview – Opening and Locking from	
Outside	20
Opening and Locking from Outside.....	21
Opening and Locking from Inside	23
Opening and Closing Luggage	
Compartment Lids	24
Malfunctions when Opening and Closing.....	26
Trunk Entrapment	29

Never invite car theft!

An unlocked car with the key in the ignition lock invites car theft.

A **gong alarm** is standard equipment in your Porsche. The gong alarm will sound if you open the driver's door while the key is still in the ignition lock. It is your reminder to pull the key out of the ignition lock and to lock the doors.

WARNING

Unattended vehicle

Never leave your vehicle unattended with the key in the ignition lock, especially if children and/or pets are left unattended in the vehicle. They can operate power windows and other controls. If the engine is left running, they may accidentally engage the shift lever. Serious personal injury or death could result from loss of control of the vehicle.

- ▷ Always remove the ignition key.
 - ▷ Always set the electric parking brake.
 - ▷ Lock the doors with the key or with the remote control.
-

To protect your vehicle and your possessions from theft, you should always proceed as follows when leaving your vehicle:

- ▷ Close windows.
- ▷ Activate the electric parking brake.
- ▷ Remove ignition key (switch ignition off in vehicles that have Porsche Entry & Drive).
- ▷ Remove valuables (e.g. car documents, radio control module, cell phones, house keys) from the car.
- ▷ Lock doors.
- ▷ Lock the glove compartment.
- ▷ Close storage trays.

Notes on the Key and Central Locking System

Key

You are provided with two car keys with integrated emergency key. These keys operate all the locks on your vehicle.

- ▷ Be careful with your car keys: do not part with them except under exceptional circumstances.
- ▷ Remove and take the ignition key with you, even if leaving the vehicle only briefly. Do not leave the ignition key in the vehicle.
- ▷ Inform your insurance company of any loss or theft of car keys or if extra or replacement keys have been cut.
- ▷ Third parties can still operate the mechanical locks with a lost key.

Emergency operation

- ▷ Please see the chapter “EMERGENCY OPERATION – UNLOCKING THE IGNITION KEY” on page 27.

Replacement keys

Car keys can only be ordered through an authorized Porsche dealer. Sometimes, this may take a long time.

You should therefore always keep a spare key convenient. Keep it in a safe place, but under no circumstances in or on the vehicle.

The key codes of new keys have to be “taught” to the vehicle control unit by an authorized Porsche dealer. All keys belonging to the vehicle must also be taught again for this purpose.

“Teach-in” can be carried out for a total of 8 vehicle keys.



Information

Third parties can continue to operate the mechanical locks using the lost key.

- ▷ Please consult an authorized Porsche dealer for blocking the lost key.
- ▷ Furthermore, it is recommended having the mechanical locks replaced by an authorized Porsche dealer.



Panic button

In dangerous situations or when one's own safety is threatened, it is possible to draw attention to the situation by triggering an alarm.

To trigger an alarm

- ▷ Press button.
The horn sounds and the emergency flasher flashes.

To stop the alarm

- ▷ Press button again or unlock the vehicle.
The horn becomes silent and the emergency flasher goes out.



Emergency key

Removing emergency key

1. Push the release button to the side.
2. Pull out the key.

Inserting emergency key

- ▷ Slide in the key until the release button audibly engages.

Central Locking System

USA: KR55WK50138

Canada: 7812D-5WK50138

This device complies with Part 15 of the FCC Rules and RSS-210 of Industry Canada.

Operation of this device is subject to the following two conditions:

1. This device may not cause harmful interference, and
2. this device must accept any interference received including interference that may cause undesired operation.

Changes or modifications not expressly approved by the party responsible for compliance could void the user's authority to operate the equipment.

Information

The manufacturer is not responsible for any radio or TV interference caused by unauthorized modifications to this equipment.

Such modification could void the user's authority to operate the equipment.

Any changes or modifications not expressly approved by Porsche could void the user's authority to operate this equipment.

Your vehicle is equipped with a central locking system. The following are unlocked or locked together:

- Doors
- Filler flap

The central locking system is always activated when the vehicle is unlocked and locked.

On the multi-function display of the instrument panel, you can set different variants for locking and unlocking. You can open all doors irrespective of the setting made.

The vehicle cannot be locked if the driver's door is not completely closed.

If one of the following components is not completely closed when you try to lock the vehicle the door is not locked:

- vehicle doors
- luggage compartment lid

The indication by the emergency flasher and by the acoustic signal will be provided after all doors and the luggage compartment lid are closed.

Information

When locking the vehicle with only the driver's door closed, the vehicle will be pre-locked. Make sure that the key is not inside the vehicle when closing the open passenger's door/luggage compartment lid.





Brief Overview – Opening and Locking from Outside

This brief overview does not replace the information provided under “OPENING AND LOCKING FROM OUTSIDE”.

Warnings, in particular, are not replaced by this brief overview.



Key

What do I want to do?	What do I have to do?	What happens?
Unlocking	Press the button  on the key once . Press the button  on the key twice within 5 seconds.	The emergency flasher flashes once. The driver's door can be opened. The emergency flasher flashes once. Both vehicle doors can be opened.
Locking	Press the button  on the key.	The emergency flasher flashes twice. The doors are locked.
Lock if persons/animals are remaining in vehicle (Switch off the alarm system's interior surveillance)	Please see the chapter “SWITCHING OFF INTERIOR SURVEILLANCE AND INCLINATION SENSOR” on page 159.	
Switching off alarm	Press the button  on the key to unlock the vehicle.	The alarm stops.



803-005

i Information

If you unlock the vehicle with the emergency key in the door lock, you must switch the ignition on (ignition lock position **1**) within 15 seconds of opening the door in order to prevent the alarm system from being triggered. The passenger's door remains locked. The time it takes for the alarm system to be triggered is country-dependent.

i Information

If button **A**  is pressed and a door or the luggage compartment lid is not opened, the vehicle is locked again automatically after 30 seconds.

- A - Unlocking the vehicle
- B - Locking the vehicle
- C - Unlocking the front luggage compartment lid and doors
- D - Unlocking the rear luggage compartment lid and doors
- E - Emergency key
- F - Panic button

Opening and Locking from Outside



Use the buttons on the key to unlock and lock the vehicle.



3G1_007

Unlocking and opening doors

Unlocking with the key

1. Press button  **once**.
The emergency flasher flashes once.
The driver's door is unlocked.
or
Press button  **twice** within 5 seconds.
The emergency flasher flashes once.
Both vehicle doors are unlocked.
2. Pull the door handle.

Information

The vehicle is locked automatically after 30 seconds if none of the doors or the luggage compartment is opened.

If the interior surveillance system and inclination sensor have been switched off (restricted anti-theft protection), this also remains the case after automatic relocking.

As a result, the doors can be opened from inside by pulling the door opener.

- ▷ Inform any persons remaining in the vehicle that the alarm system will be triggered if the door is opened.

When locked again, the interior surveillance system and inclination sensor are activated once more.

Side-selective door unlock function

When unlocking the vehicle, you can choose to unlock only the driver's door or also the passenger's door. You can unlock both doors irrespective of the selected setting.

- ▷ Press button  on the key twice within 5 seconds.

For information on modifying the opening and locking settings:

- ▷ Please see the chapter "LOCKING SETTINGS" on page 104.

Locking doors

Locking with the key

1. Close the door.
2. Press button  **once**.

The emergency flasher flashes twice and an acoustic signal will sound twice.

The doors cannot be opened from outside.

or

If persons or animals are remaining in the vehicle, press button  **twice** within 2 seconds.

The emergency flasher emits one long flash. The alarm system's interior surveillance is switched off.

The doors can be opened from inside by pulling on the door opener.

- ▷ Inform any persons remaining in the vehicle that the alarm system will be triggered if the door is opened.

Information

When locking the vehicle with only the driver's door closed, the vehicle will be pre-locked. Make sure that the key is not inside the vehicle when closing the open passenger's door/luggage compartment lid.

Information

The emergency flasher indicates that the vehicle has been locked successfully only when all the doors, the engine compartment lid and the tailgate are closed.

Information

The vehicle cannot be locked if any of the doors or the luggage compartment are not completely closed.

A warning signal sounds in the passenger compartment and a warning message appears on the multi-function display.

The key must be outside the vehicle when locking the vehicle doors, otherwise the vehicle doors cannot be locked.

If the key is out of range, the vehicle doors and the luggage compartment can no longer be opened after the vehicle is locked.

Automatic door locking and automatic door unlocking

 **WARNING** Emergency auto lock override

In an emergency situation where you need to exit the car through an automatically locked door, remember the following procedure to open the door.

- ▷ Unlock the doors by pressing the central locking button **or**
 - ▷ Pull the inner door handle to open the door.
-

In the multi-function display of the instrument panel, you have the option of selecting diverse variants of automatic door locking and automatic door unlocking.

For information on modifying the opening and locking settings:

- ▷ Please see the chapter “LOCKING SETTINGS” on page 104.

Opening and Locking from Inside

The factory settings of the vehicle are described in this section.

In the multi-function display in the instrument panel, you can change the settings and store them on the respective key for vehicles with memory.

For information on modifying the opening and locking settings:

- ▷ Please see the chapter “LOCKING SETTINGS” on page 104.

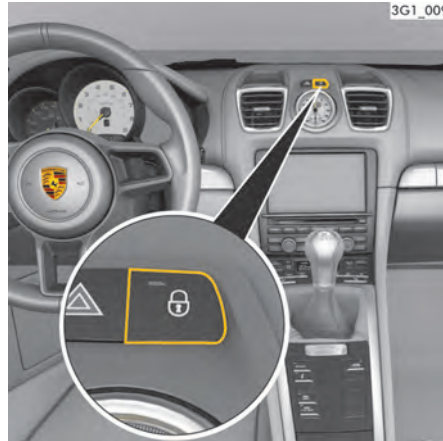

Central locking button

Locking doors

- ▷ Press the central locking button.
When the ignition is switched on, the indicator light in the button lights up.
Both vehicle doors will be locked (only if all doors are closed).
The doors can be opened from inside by pulling on the door opener.

Automatic with Auto Lock

If this function is activated, the vehicle is locked automatically when a speed of approximately 2 mph (5 km/h) is exceeded.

For information on modifying the opening and locking settings:

- ▷ Please see the chapter “LOCKING SETTINGS” on page 104.

Unlocking doors

- ▷ Press the central locking button.
The indicator light on the button goes out.
Both vehicle doors will be unlocked.

Automatic with Auto Unlock

The vehicle is automatically unlocked when the ignition key is removed.

For more information on modifying the opening and locking settings:

- ▷ Please see the chapter “LOCKING SETTINGS” on page 104.

Information

If the vehicle was locked using the car key or the emergency key, it cannot be unlocked with the central locking button.

Information

In the event of an accident with airbag deployment, the doors are unlocked automatically to facilitate fast access for helpers. The emergency flasher is also activated automatically.

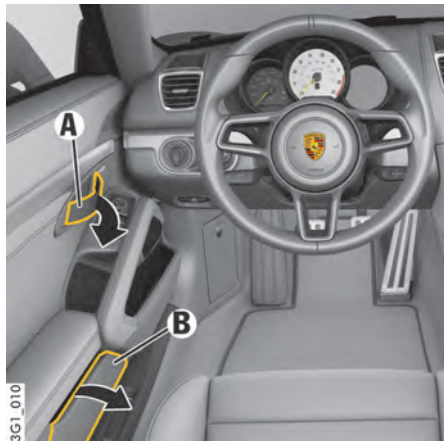

- A - Door opener
- B - Door storage tray

Opening doors

- ▷ Pull door opener (**arrow**) once.

Door storage tray

Opening storage tray

- ▷ Open the cover **B**.

Keep the storage tray closed while driving for safety reasons.

Opening and Closing Luggage Compartment Lids



Unsecured luggage compartment lids

If the luggage compartment lids are not secured properly, they could fly up, blocking your vision and causing loss of control.

- ▷ Should you notice at any time while driving that one of the lids is not secured properly, please stop immediately in a suitable place and close it.

Opening front luggage compartment lid

NOTICE

Risk of damage to front luggage compartment lid or windshield wipers.

If the windshield wipers are pulled forward when you open the front luggage compartment lid, the wipers or the luggage compartment lid could be damaged.

- ▷ Make sure that the windshield wipers are not pulled out forwards when opening the luggage compartment lid.
- ▷ Always switch off windshield wipers before opening the luggage compartment lid (wiper switch in position **O**).

For information on windshield wipers:

- ▷ Please see the chapter "WINDSHIELD WIPER AND HEADLIGHT WASHER SYSTEM" on page 70.

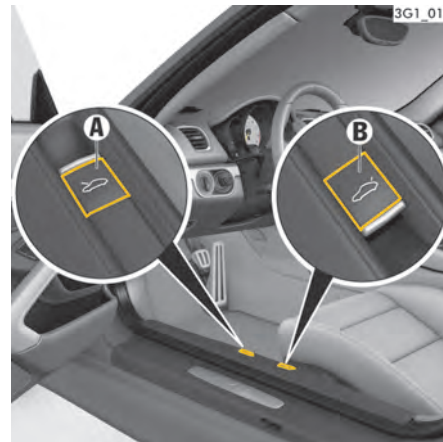

- A - Front Luggage compartment lid
- B - Rear Luggage compartment lid

1. Open the driver's door.
2. Pull the release lever **A** next to the driver's seat.
The front luggage compartment lid is now unlocked.



3. Raise lid slightly and unlatch the safety catch with the red lever (**arrow**).
4. Open the luggage compartment lid fully.

Closing front luggage compartment lid

1. Lower the lid and let it fall into the lock. Push the lid closed with the palm of your hand in the area of the lock.
2. Check that the lid has correctly engaged in the lock.

When the vehicle is in motion, a message will appear on the multi-function display in the instrument panel if the lid is not closed properly.

Opening the rear luggage compartment lid

1. Opening the driver's door.
2. Pull the release lever **B** next to the driver's seat. The rear lid is unlocked.
3. Lift up the rear lid slightly and open.



i Information

- The rear lid can be held open in **2 positions**.
- ▷ **Position 1:** Raise rear lid up to pressure point.
 - ▷ **Position 2:** Raise rear lid beyond the pressure point.

Closing the rear luggage compartment lid

1. Pull down the rear lid by the handle recess (**arrow**) and allow it to fall into the lock. Then press down on the lock area with the palm of your hand.
2. Check that the rear lid has correctly engaged in the lock.

When the vehicle is in motion, a message will appear on the multi-function display in the instrument panel if the rear lid is not closed properly.



Unlocking and opening front and rear luggage compartment lid with the key

i Information

When the front luggage compartment lid and/or rear luggage compartment lid is unlocked, the vehicle doors are also unlocked.

1. Press the or button. The lid/rear lid is unlocked.
2. Lift up the lid/rear lid slightly and open. For the front luggage compartment lid, additionally unlatch the safety catch with the red lever.

Malfunctions when Opening and Closing

Emergency operation of front luggage compartment lid

If the vehicle battery is discharged, the front luggage compartment lid can be opened only by connecting an external electrical power source.

- ▷ Please see the chapter “EMERGENCY UNLOCKING OF FRONT LUGGAGE COMPARTMENT LID” on page 204.

Only one door is unlocked

The setting for locking and unlocking the doors has been changed on the multi-function display in the instrument panel.

- ▷ Please see the chapter “SETTING DOOR UNLOCKING” on page 104.

You can open both doors irrespective of the selected setting.

- ▷ Press button  on the key **twice** within 5 seconds.

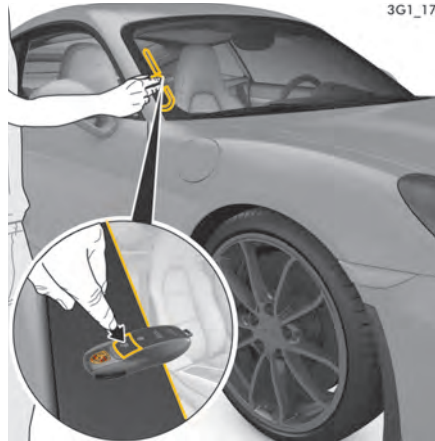

The vehicle cannot be unlocked

Remote control of the vehicle key may

- fail due to a fault,
- due to a flat key battery,
- not function correctly due to radio waves

If the vehicle cannot be opened, then:

1. Place the vehicle key at the outside edge of the windshield on the **passenger's side** and, at the same time, press button  (**illustration**).

If the vehicle still cannot be opened, then:

2. Remove the emergency key from the vehicle key.
Please see the chapter “EMERGENCY KEY” on page 19.

3. Unlock and open the driver's door with the emergency key.
For this purpose, lift and hold the door handle. Insert the emergency key in the door lock, turn 90° anti-clockwise and remove the emergency key again.
4. Release the door handle and open the door by pulling the door handle again.
5. Switch on the ignition within 10 seconds to prevent the alarm system from triggering.



Emergency operation – unlocking the ignition key

If the vehicle battery is discharged, the ignition key can be removed only if the emergency operation is performed.

1. Grasp the fuse box cover on the driver's side at the finger hole and pull it off.
2. Unclip metal hook **A** on the inside of the fuse box cover.

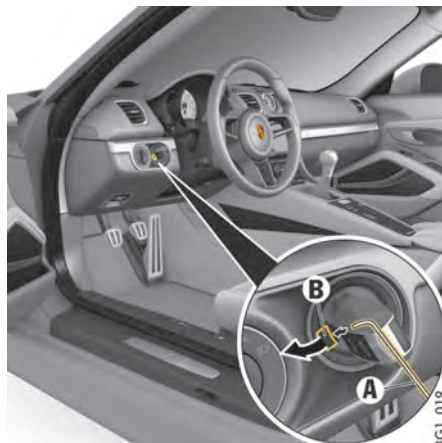

3. Use metal hook **A** to remove the plastic cover **B** from the ignition lock. Make sure not to lose the plastic cover **B**.

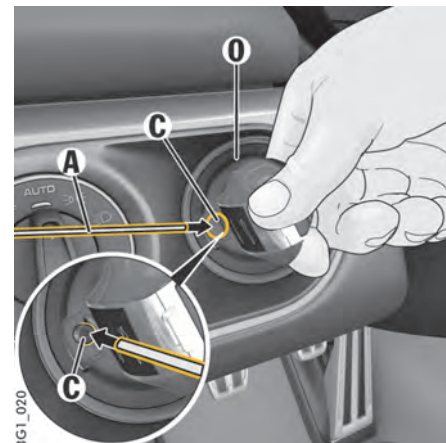

4. Ignition key to ignition lock position **O** (initial position).
5. Press metal hook **A** into opening **C**. You will hear an unlocking noise.
6. Remove the control unit/ignition key in initial position **O**.
7. Re-fit the plastic cover **B**.



Door lock under door handle (driver's side)

The vehicle cannot be locked

This is recognizable by the fact that the emergency flasher does not flash and there is no locking noise.

The remote control of the key may

- fail due to a fault,
- due to a discharged key battery,
- not function correctly due to radio waves (e.g. mobile phone) in the vicinity of the vehicle (also radio contact between remote control and vehicle in the case of Porsche Entry & Drive).

Emergency locking if the central locking system has failed

If the vehicle cannot be locked, then:

1. Remove the emergency key from the vehicle key.
Please see the chapter "EMERGENCY KEY" on page 28.
2. Open the driver's door.

3. Lift the door handle on the driver's door **(ILLUSTRATION)**.
Insert the emergency key in the door lock, turn 90° clockwise and remove the emergency key again.
Successful locking is indicated by the emergency flasher flashing twice.
4. Release the door handle and shut the door.
The driver's door is now locked.
5. To lock the **passenger's door** using the emergency procedure, insert the emergency key in the door lock in the driver's door again, turn 90° clockwise and remove the emergency key again.
The passenger's door is now locked.

Information

The passenger's door cannot be locked using the emergency procedure if the central locking system is defective.

Information

If the central locking system is defective, operating the lock cylinder in the driver's door will lock all functioning locking elements of the central locking system.

- ▷ Have the fault in the central locking system remedied at your nearest authorized Porsche dealer.



Emergency key

Removing emergency key

1. Push the release button to the side.
2. Pull out the key.

Insert emergency key

- ▷ Push in the key until the release button engages audibly.

Information

Different vehicle settings are stored on the respective key when the vehicle is locked, provided the vehicle is fitted with the relevant equipment.

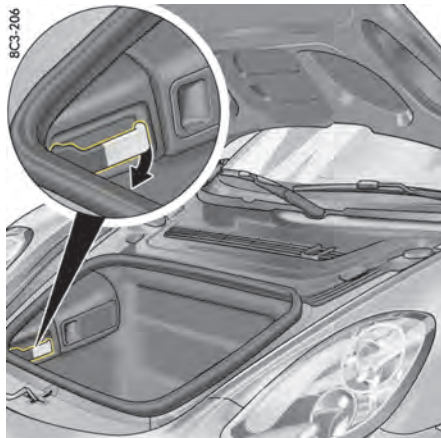

Unlocking handle in the **front** luggage compartment

Trunk Entrapment

Your vehicle is equipped with an internal trunk release mechanism.

A person trapped in the front luggage compartment can release the lid from the inside using the unlocking handle.

The handle is fluorescent and glows in the dark.

Information

- ▷ When loading the luggage compartment, make sure that items of luggage or other objects cannot become caught on the handle. This could cause the luggage compartment to open unintentionally.

Function

If the luggage compartment lid is unlocked with unlocking the handle, the lid can be opened from the inside immediately.

A warning message in the multi-function display lights up when unlocking handle is operated.

- ▷ Stop the vehicle immediately when the warning message lights up.
- ▷ Check the luggage compartment.
- ▷ Close the lid.

DANGER

Unsecured luggage compartment lids

If the warning message in the multi-function display lights up when the vehicle is in motion, the lid may impact in front of the windshield and can tear off.

- ▷ Stop the vehicle immediately when the warning message lights up.
- ▷ Check the luggage compartment.
- ▷ Close the lid.

Information

The lid cannot be opened from the inside if the battery is disconnected or empty.

Safety reasons require that you unscrew the latch striker of the lid lock if you plan to put the vehicle out of operation for an extended period.

- ▷ Please consult your authorized Porsche dealer. They will advise you about the necessary measures.

Seats, Mirrors and Steering Wheel

Seat Adjustment and Head Restraints	31
Seats	31
Seat Heating	33
Safety Belts.....	33
Airbag Systems	35
Child Restraint Equipment.....	39
Top Tether	43
Exterior Mirrors	44
Interior Mirror	45
Steering Wheel Adjustment	46
Sun Visors.....	47
Vanity Mirror.....	47

Seat Adjustment and Head Restraints

DANGER

Improper safety belt use

Safety belts only offer protection when the backrest is upright and the belts are properly positioned on the body.

Improperly positioned safety belts or safety belts worn by passengers in an excessively reclined position can cause serious personal injury or death in an accident.

- ▷ Do not operate the car with the driver or passenger backrests excessively reclined.
- ▷ Please see the chapter “SEAT POSITION” on page 31.

WARNING

Seat adjustment while driving

The seat may move further than desired if you adjust it when driving. You could lose control of the vehicle.

- ▷ Do not adjust seats while the vehicle is in motion. The backrest locks must be engaged at all times while the vehicle is in motion.

CAUTION

Seat adjustment

If persons or animals are in the movement range of the seat during seat adjustment, parts of the body could get trapped or crushed.

- ▷ Adjust the seat so that no-one is put at risk.
- ▷ Do not activate the comfort memory button if there is any risk of the seat crushing the occupant.
- ▷ Cancel automatic adjustment by pressing any of the seat adjustment buttons.

- ▷ Do not leave children in the vehicle unattended, since they may depress the setting buttons and crush themselves or another occupant.

NOTICE

Risk of damage to windshield, sun visor, etc. when the seat is adjusted or folded back or forward.

- ▷ Adjust the seat so that the seat backrest is not in contact with any other object.

The driver and passenger seats provide integrated head restraints in the backrests. The head restraints are not adjustable.

WARNING

Failure to adjust head and backrests

All occupants, including the driver, should not operate a vehicle or sit in a vehicle's seat until the headrests and backrests are placed in their proper positions so that the risk of neck injuries is minimized in the event of a crash.

- ▷ Adjust the backrest's inclination such that the headrest is in an upright position.
- ▷ Driver and passengers should be seated upright and in the center of their seats.

Seats

Seat position

An ergonomically correct sitting position is important for safe and fatigue-free driving. We recommend the following procedure for adjusting the driver's seat to suit individual requirements:

1. Adjust the seat height to give yourself enough headroom and a good overview of the vehicle.
2. Adjust the seat in fore-and-aft direction so that your leg is not fully straight and your entire foot is on the pedal when pressing the pedals fully.
3. Grip the top half of the steering wheel. Set the backrest angle (backrest angle is not adjustable at the full bucket seat) and the steering wheel position so that your arms are almost outstretched. However, your shoulders must still rest on the backrest.
4. Adjust the seat fore-and-aft setting if necessary.

Adjusting the seat

WARNING

Seat adjustment while driving

The seat may move further than desired if you adjust it when driving. You could lose control of the vehicle.

- ▷ Do not adjust seats while the vehicle is in motion. The backrest locks must be engaged at all times while the vehicle is in motion.

CAUTION

Seat adjustment

If persons or animals are in the movement range of the seat during seat adjustment, there is a risk of parts of the body being squeezed or crushed.

- ▷ Adjust the seat so that no-one is put at risk.

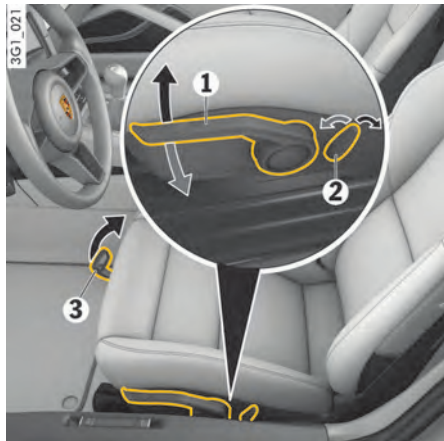

Sports seat/Sports seat plus

1 Height adjustment

- ▷ Use lever **1** in a pumping movement:
Upwards = seat moves upwards
Downwards = seat moves downwards

2 Backrest angle

Operate switch **2** until the desired backrest angle is reached.

3 Fore-and-aft adjustment

- ▷ Pull up locking lever **3**.
Move seat to desired position and release lever.
Ensure that the seat engages correctly.



Adaptive sports seat plus

1 Seat angle adjustment

2 Height adjustment

3 High support adjustment

4 Seat cushion side bolster adjustment

5 Backrest side bolster adjustment

6 Fore-and-aft adjustment

7 Backrest angle adjustment

8 Lumbar support adjustment

- ▷ Press each control in the direction indicated by the **arrows** until the desired setting is reached.



Seat backrest

Folding forward

- ▷ Pull up lever in the side part of the backrest and fold the backrest forward.

Folding back

- ▷ Tilt back and engage the backrest so that it cannot tip forward when you brake.

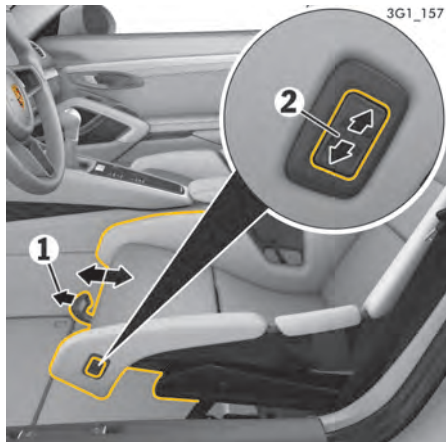

Full bucket seat

Child restraint systems must not be used on full bucket seats.

1 Fore-and-aft adjustment

- ▷ Pull up locking lever **1**.
Move seat to desired position and release lever.

Ensure that the seat engages correctly.

2 Height adjustment

- ▷ Press the control **2** in the **direction indicated by the arrows** until the desired settings or the limit position is reached.



Seat Heating

The seat heating is ready for operation when the engine is running. The heating power can be adjusted to one of three settings by repeatedly pressing the heated seat button.

Switching on

- ▷ Press heated seat button (repeatedly).
The number of illuminated indicator lights shows the selected heat setting.

Switching off

- ▷ Press the heated seat button (repeatedly) until all indicator lights go out.

Seat heating is not available when the interior temperature is high.

If the charging condition of the battery is critical, the seat heating function is restricted initially and then switched off.

Safety Belts

Safety belts help protect occupants during accidents. They are the most important part of the restraint system. Most states require the use of safety belts at all times.



Unfastened or incorrectly used safety belts

Safety belts do not offer any protection in the event of an accident if they are not worn. Incorrectly fastened safety belts can increase the risk of injury in the event of an accident.

- ▷ All occupants of the vehicle must wear safety belts for their own safety. Share all the information in this section with your passengers.
- ▷ Use appropriate child restraint systems for all children.
- ▷ Safety belts must be positioned on the body as to restrain the upper body and lap from sliding forward. Improperly positioned safety belts can cause serious personal injury in case of an accident.
- ▷ The shoulder belt should always rest on your upper body. The shoulder belt should never be worn behind your back or under your arm.
- ▷ For maximum effectiveness, the lap belt should be worn low across the hips.
- ▷ Pregnant women should position the belt as low as possible across the pelvis. Make sure it is not pressing against the abdomen.
- ▷ Never use **one** safety belt for two persons at the same time.
- ▷ Remove any loose, bulky items of clothing that prevent the belt from fitting correctly.
- ▷ Belts should not be worn twisted or loose.
- ▷ Do not lay the belt across hard or breakable objects (glasses, ball-point pens, pipes, etc.).

Such objects, can constitute an additional risk to occupants' safety.

- ▷ Several layers of heavy clothing may interfere with proper positioning of belts.
- ▷ Belts must not rub against sharp objects or damage may occur to the belt.

⚠ DANGER

Using damaged safety belts

Damaged, heavily stressed or worn safety belts cannot protect the body sufficiently in the event of an accident.

- ▷ Check all belts regularly for signs of damage in the fabric, and check that the buckle and attachment points function correctly. Keep belt buckles free of any obstruction that may prevent a secure locking.
- ▷ Belts that have been subjected to excessive stretch forces in an accident must be inspected or replaced to ensure their continued effectiveness in restraining you. The same applies to belt tensioner systems which have been triggered. In addition, the anchor points of the belts should be checked.
- ▷ If safety belts do not work properly, see your authorized Porsche dealer immediately.
- ▷ If the belts show damage to webbing, bindings, buckles or retractors, they should be replaced to ensure safe operation.
- ▷ Do not modify or disassemble the safety belts in your vehicle.
- ▷ The belts must be kept clean or the retractors may not work properly. Please see the chapter "CLEANING THE SAFETY BELTS" on page 180.
- ▷ Never bleach or dye safety belts.

- ▷ Do not allow safety belts to retract until they are completely dry after cleaning or this may cause damage to the belt.

Safety-belt pretensioner

Safety safety-belts are tightened in an accident, depending on the force of the collision.

The safety-belt pretensioners are triggered:

- In the event of front and rear impact
- In the event of side impact
- If the vehicle turns over



Information

The safety-belt pretensioner system can be triggered only once; the system must then be replaced.

Work may be carried out on the safety-belt pretensioner system only by an authorized Porsche dealer.

Smoke is released when the safety-belt pretensioners are triggered. This does not indicate a fire in the vehicle.



Warning light and warning message

An audio-visual warning system is interconnected with the driver's and passenger's safety belt.

The following functions serve as a reminder to fasten the safety belts; they remain active until the tongue of the driver's or passenger's safety belt is inserted into its buckle:

- ▷ The warning light on the instrument panel lights up when the ignition is switched on.
- ▷ A warning appears on the multi-function display in the instrument panel.
- ▷ A warning signal (gong) sounds when the vehicle speed exceeds 24 km/h (15 mph).

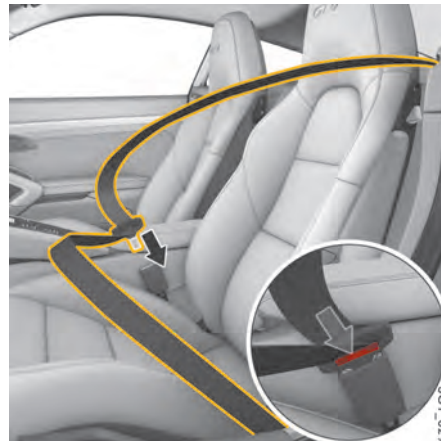

Fasten safety-belt

1. Assume a comfortable sitting position.
2. Adjust the seat backrest (backrest angle is not adjustable at the full bucket seat) so that the belt always rests on your upper body and runs across the middle of your shoulder.
3. Grasp the belt tongue and pull the belt in a slow, continuous motion across your chest and lap.



Information

The belt may be blocked if the vehicle is standing at an angle or the belt is pulled out using a jerking movement.

The belt cannot be pulled out while accelerating and slowing down, when cornering and when driving uphill.

4. Insert the belt tongue into the appropriate buckle on the inboard side of the seat until it locks securely with an audible click.

5. Make sure that belts are not trapped or twisted and that they are not rubbing on sharp edges.
6. The horizontal section of the belt should always fit snugly across the pelvis. Therefore, after fastening the belt, always pull the diagonal part of the belt upward. Pregnant women should position the belt as low as possible across the pelvis, and ensure that it is not pressing against the abdomen.
7. Also pull on the diagonal section of the belt now and again during the journey to ensure that the horizontal section remains tight.



Opening belt buckle and removing belt

1. Hold the belt tongue.
2. Press the red button on the belt buckle.
3. Guide the belt tongue to approx. 7 cm below the deflection bracket of the strap reel (**figure**) and lock using the plastic slide (**figure**). The function of the plastic slide is to hold the belt tongue in an easily accessible position.

Airbag Systems

The vehicle is equipped with airbags and lap/shoulder belts at both front seating positions. The airbags are a supplemental restraint at those seating positions.

The airbags in combination with the safety belts make up a safety system which offers the driver and the passenger the greatest known protection from injuries in case of an accident.

Your vehicle is equipped with occupant sensing for the passenger's seat in accordance with U.S. Federal Motor Vehicle Safety Standard 208.

Even though your vehicle is equipped with airbags, **the safety belts must be worn at all times**, because the front or side airbags deploy depending on the force and angle of impact.

Below the deployment threshold of the airbag system, and during types of collisions which do not cause the airbag deployment, the safety belts provide the primary protection to the occupants when correctly worn. **Therefore, all persons within the vehicle must wear safety belts at all times** to minimize the risk of severe injury or death in the event of a crash.

▷ Please see the chapter "SAFETY BELTS" on page 33.

The **front airbags** are located under the padded steering wheel panel on the driver's side, in the dashboard on the passenger's side, and in the knee area for both the driver and the passenger. The **side airbags** are installed on the side in the seat backrests.

The **head airbags** are installed in the door linings.



Information

To minimize the risk of severe injury or death in the event of a crash, all occupants, including the driver, should always wear their safety belts whether or not an airbag is also provided at their seating position.



DANGER

Safety belts and positioning

Airbags only can offer protection, if all occupants fasten their safety belts and retain a proper sitting position.

To provide optimal occupant protection, airbags must inflate at very high speed. If you are not wearing your safety belt or are too close to the airbag when it is deployed, inflating airbags can result in serious personal injury or death.

▷ Always fasten safety belts.

- ▷ Make sure there are no people, animals or objects between the driver or passenger and the area into which the airbags inflate.
- ▷ Sit back as far from the dashboard or steering wheel as is practical, while still maintaining full vehicle control.
- ▷ Always hold the steering wheel by the outer rim. Never rest your hands on the center of the steering wheel where the airbag module is located.

- ▷ Always keep feet in the footwell while driving. Do not put feet on the dashboard or the seat area. Do not lean against the inside of the door or outside the window while the vehicle is moving.



DANGER

Safe storage of objects

Objects and load have to be stored securely to keep from causing injury.

- ▷ Do not transport heavy objects on or in front of the passenger seat. These could impair the function of the airbags, the safety belts, and occupant sensing.
- ▷ Do not hang objects (e.g., jackets, coats, coat hangers) over the backrest.
- ▷ Objects must not protrude out of the door storage compartment.
- ▷ Do not add any additional coverings or stickers to the steering wheel or in the area of the passenger airbag, side airbags, knee airbags, and head airbags. Doing so may adversely affect the functioning of the airbag system or cause harm to the occupants if the airbag system should deploy.
- ▷ Do not use protective seat covers.
- ▷ No objects should be placed over or near the airbag on the instrument panel, because any such objects could cause harm if the vehicle is in a crash severe enough to cause the airbag to inflate.
- ▷ Give your passenger all of the information in this chapter.



DANGER

Modification to airbag system

A modified airbag system cannot offer protection. They may not trigger or could trigger in an uncontrolled way. An uncontrolled triggering of the airbag system can result in serious personal injury or death.

- ▷ Do not modify the seat coverings, since such changes can block the seat-mounted side airbag. Do not attach additional cushions, protective coverings, or pillows to the seats. Do not affix things to the seats or cover them with other materials. Do not cover the back of the backrest. Do not make changes to the seats, the cushion or foam, the occupant sensor, and to the seat base frame.
- ▷ No changes must be made to the wiring or components of the airbag system. Doing so may disable the airbag system or cause inadvertent inflation.
- ▷ Do not install any wiring for electrical accessory equipment in the vicinity of the airbag wiring harnesses. Doing so may disable the airbag system or cause inadvertent inflation.
- ▷ If the warning light comes on, the airbag system should be repaired immediately by your authorized Porsche dealer.
- ▷ Using accessories not approved by Porsche can cause the occupant sensing to be impaired.
- ▷ Do not squeeze objects, such as the fire extinguisher, or first aid kit under the seat.
- ▷ Only have seats removed and installed by an authorized Porsche dealer so that occupant sensing components will not be damaged.

 **DANGER**

No Activation of already triggered Airbag Systems

Airbag systems were designed to trigger only once.

- ▷ Have triggered airbag systems replaced immediately.



Information

Airbag components (e.g. steering wheel, door lining, seats) may be disassembled only by an authorized Porsche dealer.

- ▷ When disposing of a used airbag unit, our safety instructions must be followed. These instructions can be obtained at any authorized Porsche dealer.

Function of the airbag system

Airbags are a supplemental safety system. Your primary protection comes from your safety belts. The front airbags are triggered during a frontal collision of sufficient force and direction. In the event of a side impact of corresponding force, the side airbag on the impact side is triggered.

The inflation process generates the amount of gas required to fill the airbags at the necessary pressure in fractions of a second.

Airbags help to protect the head and body, while simultaneously damping the motion of the driver and passenger in the impact direction in the event of a frontal impact or side impact.

In order to help provide protection in severe collisions which can cause death and serious injury, airbags must inflate extremely rapidly. Such high speed inflation has a negative but unavoidable side effect, which is that it can and

does cause injuries, including facial and arm abrasions, bruising and broken bones. You can help minimize such injuries by always wearing your safety belts.

There are many types of accidents in which airbags are not expected to deploy. These include accidents where the airbags would provide no benefit, such as a rear impact against your vehicle. Other accidents where the airbags are designed not to deploy are those where the risk of injury from the airbag deployment could exceed any protective benefits, such as in low speed accidents or higher speed accidents where the vehicle decelerates over a longer time. Since airbag deployment does not occur in all accidents, this further emphasizes the need for you and your passengers to always wear safety belts.

Your Porsche vehicle is equipped with electronically controlled systems that help to ensure your vehicle operates properly. These systems monitor the operation of various systems and electronically store information that is useful to service technicians when they need to diagnose and repair these systems.

Your vehicle is equipped with crash-sensing and diagnostic devices that may record information at the time of a collision, including whether the airbag and seatbelt pretensioners deployed and whether the safety belt was in use.

To retrieve this information, special equipment is needed and access to the vehicle or feature that stores that data is required. Some states only allow access to such information under restricted circumstances, including:

- In response to a request of police or other government office; or
- with the consent of the registered owner, or if the vehicle is leased, with the lessee, or

- through a discovery process in litigation; or as otherwise permitted or required by law.

Your rights with respect to the information discussed above may vary from state to state. Check your state law for further information.

Advanced airbag

Your vehicle is equipped with occupant sensing for the passenger's seat in accordance with U.S. Federal Motor Vehicle Safety Standard 208. The components of the advanced passenger airbag system include an occupant sensing system for the front passenger seat and a **PASS AIR BAG OFF** indicator lamp.

Depending on the weight, body positioning and shape acting on the passenger's seat, the passenger's airbag will automatically be switched on and off.

Depending on the angle and force of impact, the passenger's airbag which is switched-on will be triggered during a collision.

Precondition for switching the passenger's airbag on and off, depending on weight, body positioning and shape:

- Ignition is switched on.

⚠ WARNING

Improper passenger seating

Improper seating can unintentionally impair operation of occupant sensing of the passenger's airbag.

If the weight of an adult on the passenger's seat is not properly maintained, the passenger's airbag may be switched off.

- ▷ Select an upright seat position, and do not support weight on the armrests or center console, or lean out of the window while driving.
Always keep feet positioned on the floor in the footwell while driving. Do not put feet on the dashboard or the seat area.

Seat adjustment for the passenger's seat

⚠ WARNING

Reclining passenger seatback

Safety belts only offer protection when the backrest is positioned at an upright seating angle and the belts are properly positioned on the body.

- ▷ Do not operate the car with the driver or passenger backrests excessively reclined.

Vehicle modifications to accommodate persons with disabilities

Because modifications to your vehicle could compromise your advanced airbag system, please call 1-800-PORSCHE prior to having your vehicle modified.

⚠ DANGER

Inflating airbags

To reduce risk of injury or death to a child from an inflating airbag in an accident, Porsche strongly recommends:

- ▷ Please see the chapter "PASS AIR BAG OFF INDICATOR LAMP DOES NOT ILLUMINATE" on page 39.
- ▷ Before transporting a child on the passenger's seat:
Please see the chapter "CHILD RESTRAINT SYSTEMS" on page 39.

Automatic deactivation of the passenger airbag

Before transporting a child on the passenger seat:

- ▷ Please see the chapter "CHILD RESTRAINT SYSTEMS" on page 39.
- When an **up to one-year old child** is seated in the child restraint system, the front airbag is automatically deactivated on the passenger side.
- When an adult is seated in the passenger's seat the front airbag is automatically activated.



PASS AIR BAG OFF indicator lamp

i Information

Depending on the weight, body positioning and shape acting on the passenger's seat, it can occur in the case of heavier children that the passenger airbag is active or, in the case of very light adults or young persons, that the passenger airbag is deactivated.

The condition of the passenger airbag system is shown by the indicator lamp in the overhead operating console.

i Information

- ▷ After switching on the ignition, the PASS AIR BAG OFF warning light lights up for a few seconds as a check.

PASS AIR BAG OFF indicator lamp illuminates

- The passenger airbag is switched off.

PASS AIR BAG OFF indicator lamp does not illuminate

- The passenger airbag is active and ready for operation.



Unintentional passenger airbag triggering

Risk of serious personal injury or death due to the passenger airbag triggering unintentionally.

When the ignition is on and the up to one-year old child is seated in the child restraint system on the passenger seat the indicator lamp **"PASS AIR BAG OFF"** must be on.

If the **"PASS AIR BAG OFF"** indicator lamp does not light up, it could indicate a fault in the system, and the airbag could inflate in a collision, placing the child at risk of death or severe injury from the inflating airbag.

In this case:

- ▷ Do not install a child restraint system on the passenger's seat.
 - ▷ Have the fault remedied at your nearest authorized Porsche dealer.
-

Airbag Warning light

Faults are indicated by a warning light on the tachometer.

The airbag warning light illuminates when the electronic monitoring of the airbag system detects a malfunction of the sensors, safety belt system, occupant detection system, PASS AIR BAG OFF indicator lamp, related wiring, airbag modules and control units.

▷ **In the following cases you should immediately consult an authorized Porsche dealer in order to assure the airbag system is functioning properly:**

- If the warning light does not light up when the ignition is switched on **or**
- If the warning light does not go out once the engine is running **or**
- If the warning light appears while driving.

Information

If you sell your Porsche, notify the purchaser that the vehicle is equipped with airbags, and refer them to the chapter "Airbag systems" in the Owner's manual (safety and disposal rules).

Further information on the airbag system can be found on stickers attached to the sun visors, as well as on all airbag components.

For special recommendations on the use of child restraints:

- ▷ Please see the chapter "CHILD RESTRAINT SYSTEMS" on page 39.
-

Child Restraint Systems

Porsche recommends that all infants and children be restrained in child restraint systems at all times while the vehicle is in motion in accordance with applicable laws.

When possible, use only child restraint systems recommended by Porsche. These systems have been tested and adjusted to the interior of your Porsche and the appropriate child weight groups. Other systems have not been tested and could entail an increased risk of injury.

The use of infant or child restraints is required by law in all 50 US states and the Canadian provinces. The child restraint system should be one that complies with U.S. Federal/Canadian Motor Vehicle Safety Standards and should be secured by a lap belt portion of a lap-shoulder belt or for child seats equipped with Top Tether to the Top Tether anchorages.

All child restraint systems are designed to be secured in vehicle seats by lapbelts or the lapbelt portion of a lap-shoulder belt.

- ▷ Always observe the separate installation instructions for your child seat.



Improper use of child restraint

Children could be endangered in a crash if their child restraints are not properly secured in the vehicle.

- ▷ Make sure that all child restraints are properly secured.
-

A statement by the seat manufacturer of compliance with this federal standard can be found on the instruction label on the restraint and in the instruction manual provided with the restraint.

⚠ DANGER

Child restraint in passenger's seat

The use of a child restraint system in the passenger's seat can result in serious personal injury or death to the child from an airbag deployment.

To reduce risk of injury from an inflating airbag in an accident, Porsche strongly recommends:

- ▷ Please see the chapter "PASS AIR BAG OFF INDICATOR LAMP DOES NOT ILLUMINATE" on page 39.
-

⚠ DANGER

Improper use of child restraint

- ▷ Do not use child restraint systems on **full bucket seats**. Please see the chapter "INSTALLATION OF CHILD RESTRAINT SYSTEMS ON DIFFERENT SEAT VARIANTS" on page 42.
- ▷ Follow all child restraint instructions and warnings in this manual.

- ▷ When using an infant or child restraint system, be sure to follow all manufacturer's instructions on installation and use.
- ▷ Infants and small children should neither be held on the lap, nor should they share a safety belt with another occupant while the vehicle is in motion.
- ▷ Children too big for child restraint systems must use regular safety belts. A shoulder belt can be used providing it does not cross the face or the neck of the child.
- ▷ Choose a child restraint system according to the weight of the child.
- ▷ Child restraint systems that are damaged or have been heavily stressed in an accident must be replaced immediately.
- ▷ Children could be endangered in a crash if their child restraints are not properly secured in vehicle.
- ▷ Do not affix objects to child restraint systems or cover them with other materials.

Direction of installation for child restraint systems.

Group 0 and 0+: Children up to 29 lbs (13 kg)

Children of this weight must be transported in a restraint system which is installed on the passenger's seat **facing rearward**.

Group I: Children in between 20 lbs (9 kg) and 40 lbs (18 kg)

Children of this weight are transported in child restraint systems **facing forward**.

Group II: Children in between 33 lbs (15 kg) and 55 lbs (25 kg)

Children of this weight are transported in child restraint systems **facing forward**.

Group III: Children in between 49 lbs (22 kg) and 80 lbs (36 kg)

Children of this weight are transported in child restraint systems **facing forward**.

- ▷ The passenger's seat must be adjusted to the upper rear position.

Using child restraint systems in the front passenger seat

- ▷ Do not use child restraint systems on **full bucket seats**.
- ▷ Please see the chapter "INSTALLATION OF CHILD RESTRAINT SYSTEMS ON DIFFERENT SEAT VARIANTS" on page 42.

DANGER

Child restraint in passenger seat

The use of a child restraint system in the passenger seat can result in serious personal injury or death to the child from an airbag deployment.

To reduce risk of injury from an inflating airbag in an accident, Porsche strongly recommends:

- ▷ Please see the chapter "PASS AIR BAG OFF INDICATOR LAMP DOES NOT ILLUMINATE" on page 39.
 - ▷ Please see the chapter "CHILD RESTRAINT SYSTEMS" on page 39.
-

Child restraint system for up to one-year old children

When an **up to one-year old child** is seated in the child restraint system, the front airbag is automatically deactivated on the passenger side.

- ▷ Make sure that the "PASS AIR BAG OFF" indicator lamp lights up.
- ▷ Adjust the passenger's seat as far away from the airbag as possible.

DANGER

Child seat detection fault

When the ignition is on and the up to one-year old child is seated in the child restraint system on the passenger seat the indicator lamp "PASS AIR BAG OFF" must be on.

If the "PASS AIR BAG OFF" indicator lamp does not light up, it could indicate a fault in the system, and the airbag could inflate in a collision, placing the child at risk of death or severe injury from the inflating airbag.

In this case:

- ▷ Do not install a child restraint system on the passenger's seat.
 - ▷ Have the fault remedied at your nearest authorized Porsche dealer.
-

Child restraint system for children older than one year

Your vehicle is equipped with occupant sensing for the passenger's seat in accordance with U.S. Federal Motor Vehicle Safety Standard 208. Depending on the weight, body positioning and shape acting on the passenger's seat, the passenger's airbag will automatically be switched on or off.

Small adult passengers

- ▷ Make sure that the PASS AIR BAG OFF indicator lamp does not light up.

CAUTION

Adult use of front seats

When the ignition is on and the small adult passenger is seated on the passenger seat, the indicator lamp "PASS AIR BAG OFF" must be off. If the "PASS AIR BAG OFF" indicator lamp lights up, it could indicate a fault in the system.

In this case:

- ▷ Have the fault remedied at your nearest authorized Porsche dealer.
-



Full bucket seat

Installation of child restraint systems on different seat variants

Child restraint systems must not be used on full bucket seats (**Illustration**). The recommended child seat systems may be used for all other seat variants.

- ▷ Please see the chapter “CHILD RESTRAINT SYSTEMS” on page 39.
- ▷ Please see the chapter “SEATS” on page 31.

Automatic locking retractor

The safety belt for the passenger seat is equipped with an automatic locking retractor for securing the child restraint system. When activated, this retractor allows you to securely fasten the child restraint system in place so that inadvertent movements will not occur.

Before transporting a child on the passenger seat:

- ▷ Please see the chapter “CHILD RESTRAINT SYSTEMS” on page 39.

⚠ DANGER

Adjusting child seat after fastening

- ▷ After fastening the child restraint system, do not adjust the seat in any direction.

Moving the seat could adjust the safety belt against the child restraint and cause the “PASS AIR BAG OFF” indicator lamp to go off and activate the airbag system.

- ▷ Check the condition of the passenger airbag system shown by the indicator lamp in the overhead operating console.



PASS AIR BAG OFF indicator lamp

Activating the automatic locking retractor

1. If a child restraint system must be fastened to the passenger's seat, adjust the passenger's seat as far away from the airbag as possible.
2. Position child seat according to the child seat's manufacturer instructions.
3. Pull the safety belt retractor completely out. At this point the locking mechanism is activated.
4. Insert the safety belt tongue into the buckle and make certain that it is properly latched. Make no more adjustments to the seat.
5. Allow the safety belt to retract until it is tight on the child restraint system. You may further tighten the belt by pulling on it to allow more of it to retract. Make sure that excessive safety belt forces do not occur by moving the seat with the child seat installed.

Releasing the safety belt

1. Unbuckle the safety belt latch.
2. Then make certain that the belt has fully retracted. At this point the automatic locking feature will be disengaged. Seek appropriate advice from your authorized Porsche dealer about the possible installation of a Porsche child restraint system.

Top Tether

Top Tether child seats are the best option for mounting a child seat in your Porsche. Such Top Tether child seats can be installed only using the Top Tether on the rear wall behind the passenger seat. Use only child restraint systems with Top Tether recommended by Porsche. These systems have been tested and adjusted to the interior of your Porsche and the appropriate child weight groups. Other systems have not been tested and could entail an increased risk of injury.

- ▷ To ensure proper installation, see your authorized Porsche dealer
- ▷ Always observe the separate installation instructions for your child seat.

WARNING

Misuse of Childseat Restraint Anchorages

- Child restraint anchorages are designed to withstand only those loads imposed by correctly fitted child restraints. Under no circumstances are they to be used for adults safety belts or harnesses.
- ▷ Do not misuse the child restraint anchorages. Only attach **one** child seat tether per anchorage.
 - ▷ They are not designed to withstand loads imposed by adults.
-
- ▷ Please see the chapter "AUTOMATIC LOCKING RETRACTOR" on page 42.

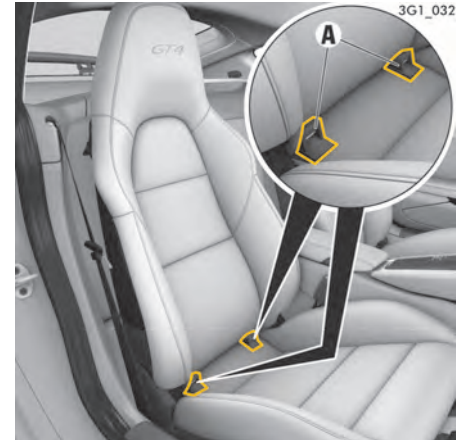

Installing a Top Tether child seat system

- ▷ Always observe the separate installation instructions for your child seat.
1. Secure the child seat to retaining lugs **A** as outlined in the operating manual for the child seat.
 2. Pull the child seat to check that both fastening points are engaged correctly.
 3. If the child restraint seat or seats require the use of a tether strap, attach the tether strap to the anchor point on the rear wall behind the passenger seat and pull it tight (**Illustration**).

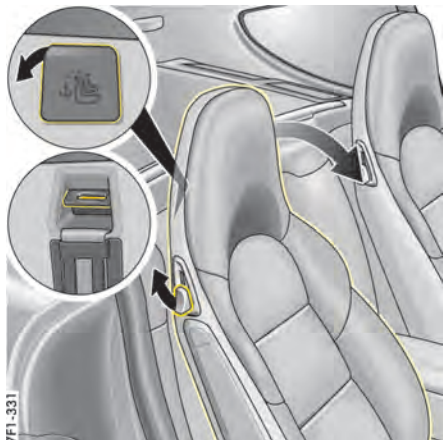

7F1_331

Upper anchorage point for child restraint systems

When using a child restraint system with a top tether, the anchorage point on the rear wall behind the passenger seat is used to secure the top tether.

Exterior Mirrors

The convex mirror on the passenger's side and the aspherical mirror on the driver's side provide a larger field of view.

⚠ WARNING

Judging distance in convex side mirror

Vehicles or objects appear smaller in convex mirrors and further away than they are in reality.

- ▷ Bear this distortion in mind when estimating the distance of vehicles behind you and when reversing into a parking space.
- ▷ Also make use of the interior mirror for judging distance.

NOTICE

Risk of damage to the exterior mirrors when washing the vehicle in a car wash.

- ▷ Fold in exterior mirrors before using the car wash.

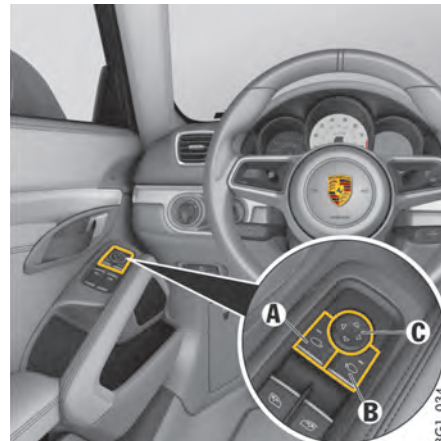

3G1_034

A - Exterior mirror selection – driver's side

B - Exterior mirror selection – passenger's side

C - Adjusting exterior mirrors

Adjusting exterior mirrors

The electrical exterior mirror adjuster is ready for operation:

- With ignition switched on.
- After the ignition is switched off and before the driver's or passenger's door is first opened, but for a maximum of 10 minutes.

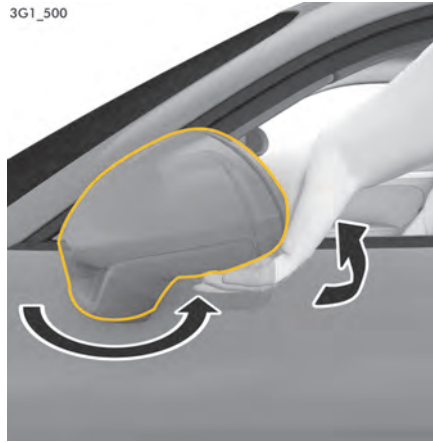
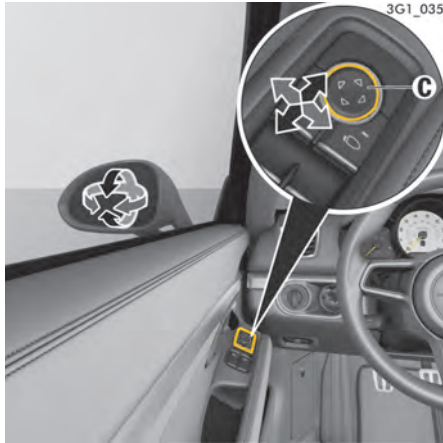

1. Press selection button **A** for the driver's side and selection button **B** for the passenger's side. The indicator light on the pressed button lights up.
2. Move the exterior mirrors to the correct position by pressing the adjustment button **C**.

If the electrical adjustment facility fails

- ▷ Adjust the mirror by pressing on the mirror face.

Folding in exterior mirrors manually

- ▷ Swivel the mirror housing diagonally upwards by hand as far as it will go.

Folding out exterior mirrors manually

- ▷ Swivel the mirror housing diagonally downwards by hand as far as it will go.

 **Exterior mirror heating**

The exterior mirror heating is activated automatically when the heated rear window is switched on while the engine is running. For information on switching on the heated rear window:

- ▷ Please see the chapter "HEATED REAR WINDOW/ EXTERIOR MIRROR HEATING" on page 59.

If the charging condition of the battery is critical, the exterior mirror heating function is restricted initially and then switched off.

Interior Mirror

The interior mirror's reflection is undistorted. When the mirror is being adjusted, the anti-dazzle lever **A** must point forwards.

- ▷ Normal position – lever forward.
- ▷ Anti-dazzle position – swivel lever back.



Automatic anti-dazzle interior mirror

Sensors on the front and rear sides of the interior mirror measure the incident light. The mirror automatically changes to anti-dazzle position or reverts to its normal state, depending on the light intensity.

i Information

The incident light within the detection area of the interior mirror must not be restricted (e.g. by stickers on the rear window or items of luggage in the luggage compartment or on the luggage compartment cover). Likewise, the incident light coming through the windscreen to the front light sensor must not be restricted (e.g. by stickers).

Switching off automatic anti-dazzle function

- ▷ Press button **B**.
The indicator light **A** goes out.

i Information

The anti-dazzle function switches off automatically if:

- Reverse gear is engaged **or**
- Interior lighting is switched on.

Switching on automatic anti-dazzle function

- ▷ Press button **B**.
The indicator light **A** lights up.

⚠ CAUTION

Electrolyte fluid may escape if the mirror glass is broken

Electrolyte fluid may escape from broken mirror glass. This fluid irritates the skin and eyes.

- ▷ If the electrolyte fluid should come into contact with the skin or eyes, rinse it off immediately with clean water.
Seek medical attention if necessary.

NOTICE

Risk of damage to paintwork, leather, plastic parts and clothing.

Electrolyte fluid can be removed only while it is still wet.

- ▷ Clean the effected parts with water.

Automatic anti-dazzle exterior mirror

The exterior mirrors change to anti-dazzle position automatically in synchronization with the interior mirror.

Steering Wheel Adjustment

The steering wheel can be adjusted manually or electrically in four directions depending on the vehicle equipment.

⚠ WARNING

Steering wheel adjustment while driving

The steering wheel may move further than desired if you attempt to adjust it when driving.

You may lose control of the vehicle.

- ▷ Do not adjust the steering wheel when driving.

⚠ CAUTION

Memory steering wheel movement

If persons or animals are in the movement range of the steering wheel during adjustment or if the person buttons are pressed unintentionally when the vehicle is at a standstill, parts of the body could get trapped or crushed.

- ▷ Do not leave children in the vehicle unattended.



3G1_039

Manual steering wheel adjustment

Adjusting steering wheel manually

1. Insert the ignition key fully into the ignition lock.
2. Push locking lever downwards.
3. Adjust steering wheel to suit the chosen backrest angle and your seat position by moving the steering wheel up or down and longitudinally.
4. Swivel locking lever back until you feel it engage.
If necessary, move the steering wheel slightly in a longitudinal direction.



3G1_042

Sun Visors

- ▷ Swivel the sun visor down to prevent dazzle from the front.
- ▷ If you are dazzled from the side, unclip the sun visor from the inner bracket and swivel it round so that it is in front of the door window.



3G1_043

Vanity Mirror

The vanity mirror on the rear of the sun visor is closed with a cover. The vanity mirror illumination is switched on automatically when the cover is opened.

CAUTION Cover of vanity mirror open

The mirror glass may break in the event of an accident and may enter the passenger compartment if the cover is open.

- ▷ Keep the cover closed when driving.

NOTICE

Risk of damage to the vanity mirror cover.

- ▷ Do not force the cover beyond its end position.

Air Conditioning

Heating and Ventilation	49
Manual Air Conditioning	51
Automatically Controlled	
2-zone Air Conditioning.....	54
Air Vents	59
Heated Rear Window/Exterior Mirror Heating ..	59

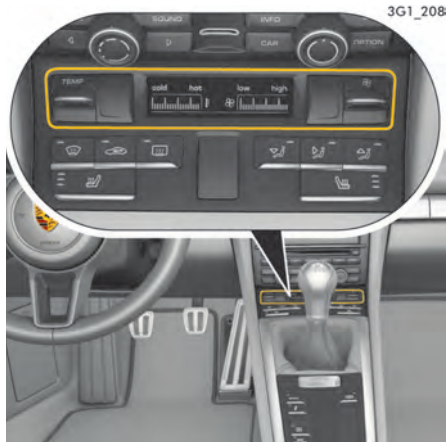

Heating and Ventilation

Air quantity, air distribution and temperature can be set on the control panel.



Defrosting windshield

Activating defrosting function

- ▷ Press button . The indicator light on the button lights up. The air flows to the windshield and the front side windows. The windshield is demisted or defrosted as quickly as possible.

Deactivating defrosting function

- ▷ Press the  button. The indicator light on the button goes out.

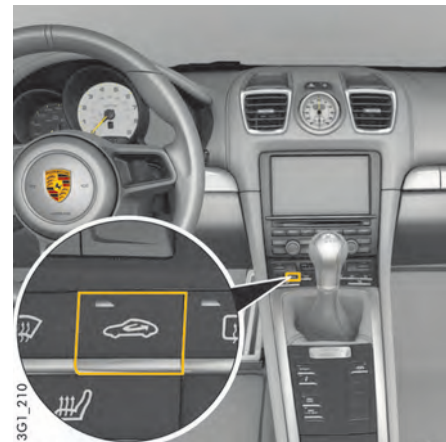

Air-recirculation mode

Switching on air-recirculation mode

- ▷ Press button . The indicator light on the button lights up. The outside-air supply is interrupted and only the inside air is recirculated.

Switching off air-recirculation mode

- ▷ Press button . The indicator light on the button goes out.



Information

Air-recirculation mode ends automatically after approx. 3 minutes.

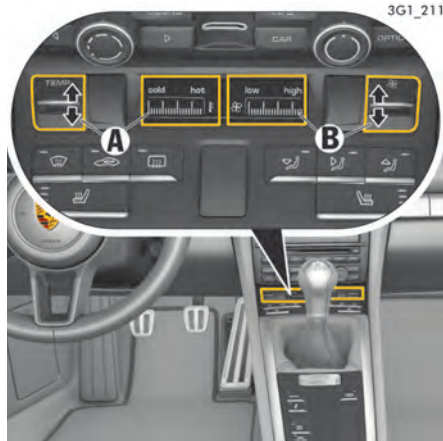

- A - Set temperature
- B - Set air quantity

Setting temperature

The selected temperature is shown on the display by a bar display.

Increasing temperature

- ▷ Press button **TEMP** upwards.
If **all bars** can be seen, the temperature is set to **maximum heat (hot)**.

Reducing temperature

- ▷ Press button **TEMP** downwards.
If **no bars** can be seen, the temperature is set to **maximum coldness (cold)**.

Setting air quantity

The selected air quantity is shown in a bar display next to the  symbol. The more bars that are displayed, the more air flows into the passenger compartment.

Increasing air quantity

- ▷ Press button  upwards.

Reducing air quantity

- ▷ Press button  downwards.

If the air quantity was reduced so much that **OFF** appears on the control panel display, the supply of air from the outside is interrupted.



 **WARNING** Air Shut-off Impairing Vision

The windows can mist up if the air quantity setting is **OFF**.

- ▷ Only select air quantity setting **OFF** for short periods.
- ▷ Press button  upwards (increase air quantity).



Setting air distribution

- ▷ Press button .
The air flows to the windshield and the side windows.
- ▷ Press button .
The air flows from the central and side vents. The air vents must be open.
- ▷ Press button .
The air flows to the footwell.
The indicator light on the button lights up.

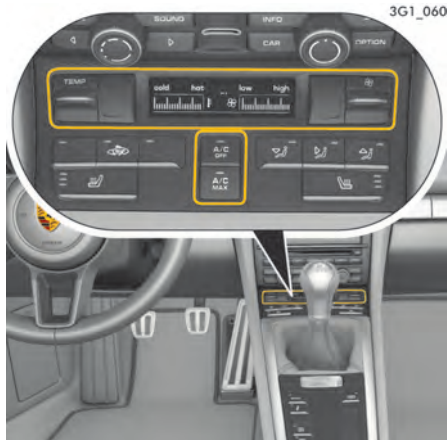

Manual Air Conditioning

The air quantity, air distribution and temperature can be set manually on the manual air-conditioning system in order to influence the interior climate.

Information on air-conditioning compressor

The air-conditioning compressor

- Can switch off briefly to ensure sufficient engine cooling if the engine is operating under extreme load.
 - Automatically switches off at temperatures below approx. 36 °F (2 °C) and cannot be switched on, even manually.
 - Operates most effectively with the windows closed.
- If the vehicle has been in the sun for a long time, it is a good idea to ventilate the interior briefly with the windows open.
- Depending on the outside temperature and humidity, condensation can drip from the evaporator and form a pool under the vehicle. This is normal and not a sign of leakage.

Information on automatic load switch-off

If the charging condition of the battery is critical, the following air-conditioning or heating functions are restricted initially and then switched off:

- Seat heating
- Seat ventilation
- Heated rear window/Exterior mirror heating
- Fresh-air blower
- Air-conditioning compressor



A/C mode

At outside temperatures above approx. 36 °F (2 °C), the air-conditioning compressor can be switched on or off manually. The air-conditioning compressor is switched off automatically at outside temperatures below approx. 36 °F (2 °C).

Switching A/C mode on

If you wish to cool the passenger compartment to a temperature lower than the outside temperature, A/C mode must be activated.

- ▷ Press button **A/C OFF**.

The indicator light on the button goes out.
The air-conditioning compressor is switched on.
The cooling function is activated.

Switching A/C mode off

A/C mode can be switched off manually to save fuel, for example.

▷ Press button **A/C OFF**.

The indicator light on the button lights up.

The air-conditioning compressor is switched off.

The cooling function is deactivated.



A/C MAX mode

In A/C MAX mode, the passenger compartment is cooled at maximum power.

Switching A/C MAX mode on

▷ Press button **A/C MAX**.

The indicator light on the button lights up.

Switching A/C MAX mode off

▷ Press button **A/C MAX**.

The indicator light on the button goes out.



Defrosting windshield

Activating defrosting function

▷ Press button .

The indicator light on the button lights up.

The air flows to the windshield and the side windows.

The windshield is demisted or defrosted as quickly as possible.

Deactivating defrosting function

▷ Press button .

The indicator light on the button goes out.

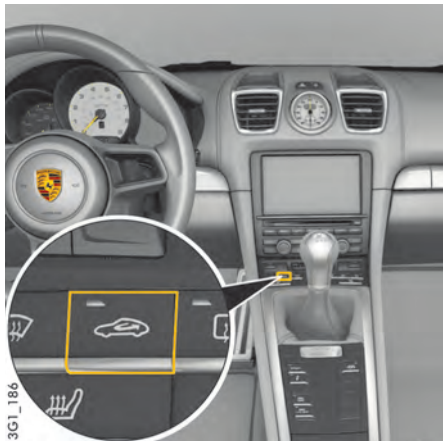

Circulating-air mode

Switching on air-recirculation mode

- ▷ Press button  .
The indicator light on the button lights up.
The outside-air supply is interrupted and only the inside air is recirculated.

Switching air-recirculation mode off

- ▷ Press button  .
The indicator light on the button goes out.

Information

If the air-conditioning compressor is switched off manually or automatically, air-recirculation mode ends automatically after approx. 3 minutes.

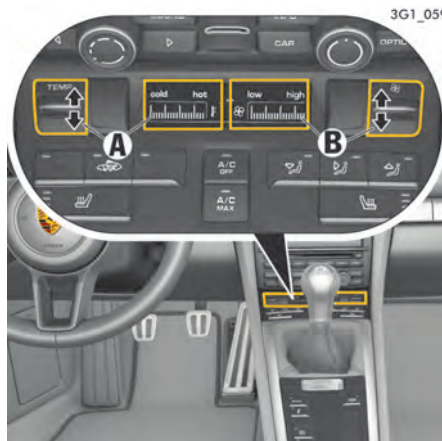

- A - Set temperature
- B - Set air quantity

Setting temperature

The selected temperature is shown on the display by a bar display.

Increasing temperature

- ▷ Press button **TEMP** upwards.
If **all bars** can be seen, the temperature is set to **maximum heat (hot)**.

Reducing temperature

- ▷ Press button **TEMP** downwards.
If **no bars** can be seen, the temperature is set to **maximum coldness (cold)**.

Setting air quantity

The selected air quantity is shown in a bar display next to the  symbol. The more bars that are displayed, the more air flows into the passenger compartment.

Increasing air quantity

- ▷ Press button  upwards.

Reducing air quantity

- ▷ Press button  downwards.

If the air quantity was reduced so much that **OFF** appears on the air-conditioning display, the outside-air supply is interrupted and the air-conditioning compressor is switched off.

 **WARNING** Impaired vision with air quantity **OFF**

The windows can mist up if the air quantity setting is **OFF**.

- ▷ Press button  upwards (increase air quantity).



Setting air distribution manually

- ▷ Press button . The air flows to the windshield and the side windows.
- ▷ Press button . The air flows from the central and side vents. The air vents must be open.
- ▷ Press button . The air flows to the footwell.

The indicator light on the button lights up.

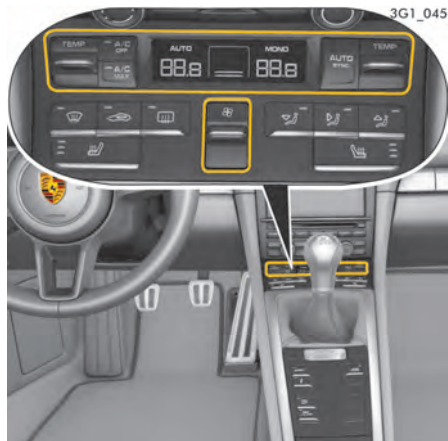

Automatically Controlled 2-zone Air Conditioning

The temperature can be set individually for the driver's and passenger's side. In automatic mode the air conditioning system exercises full control over the air temperature, air distribution, and air quantity. A number of factors (such as ambient air temperature, amount of sunlight, etc...) are used by the system to determine the optimum settings for the current situation.

Automatic mode is deactivated as soon as the settings are adjusted manually. In this case, automatic climate control still regulates the air-conditioning functions that have not been modified manually.



Interior temperature sensor

Sensors

To avoid impairing the function of the air conditioning system, the interior temperature sensor for the air-conditioning system must not be covered or taped over.

Information

Additional air conditioning settings can be made on the multi-function display on the instrument panel:

- ▷ Please see the chapter "SETTING AIR CONDITIONING" on page 104.

All air-conditioning system settings are stored on the respective vehicle key when the vehicle is locked, on vehicles with memory.

Information on air-conditioning compressor

The air-conditioning compressor

- Can switch off briefly to ensure sufficient engine cooling if the engine is operating under extreme load.
- Switches off automatically at temperatures below approx. 36 °F (2 °C) and cannot be switched on, even manually.
- Operates most effectively with the windows closed.

If the vehicle has been in the sun for a long time, it is a good idea to ventilate the interior briefly with the windows open.

- Depending on the outside temperature and humidity, condensation can drip from the evaporator and form a pool under the vehicle. This is normal and not a sign of leakage.

Information on automatic load switch-off

If the charging condition of the battery is critical, the following air-conditioning or heating functions are restricted initially and then switched off:

- Seat heating
- Seat ventilation
- Heated rear window/Exterior mirror heating
- Fresh-air blower
- Air-conditioning compressor

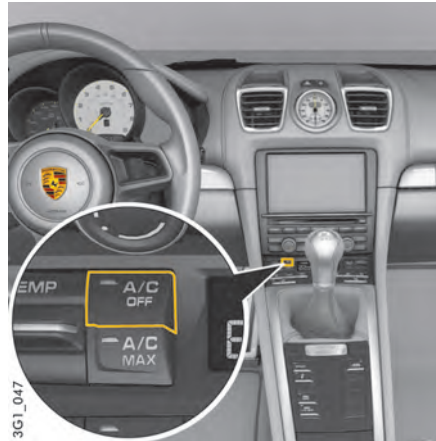

A/C mode

In automatic mode, A/C mode is activated by default.

The power for the air conditioning compressor is fully controlled by the air conditioning system depending on the current operating requirements. The air-conditioning compressor is switched off automatically at outside temperatures of less than approx. 36 °F (2 °C).

Switching A/C mode on

If you wish to cool the passenger compartment to a temperature lower than the outside temperature, A/C mode must be activated.

- ▷ Press button **A/C OFF**.
The indicator light on the button goes out.
The air-conditioning compressor is switched on.

or

Press button **AUTO/SYNC**.
The cooling function is activated.

Switching A/C mode off

A/C mode can be switched off manually to save fuel, for example.

- ▷ Press button **A/C OFF**.
The indicator light on the button lights up.
The air-conditioning compressor is switched off.
The cooling function is deactivated.

SYNC mode

In SYNC mode, the temperatures on the driver's and passenger's side are synchronized and are regulated via button **TEMP** on the driver's side.

Switching on SYNC mode

- ▷ Press button **AUTO/SYNC** and hold until SYNC appears on the display.
- ▷ Regulate the temperature on the driver's and passenger's side via button **TEMP** on the driver's side.

Switching off SYNC mode

- ▷ Press button **AUTO/SYNC** or button **TEMP** on the passenger's side.



A/C MAX mode

In A/C MAX mode, the passenger compartment is cooled at maximum power.

The interior temperature is not regulated automatically.

If the vehicle has been in the sun for a long time, it is a good idea to ventilate the interior briefly with the windows open.

Switching A/C MAX mode on

- ▷ Press button **A/C MAX**.
The indicator light on the button lights up.

Switching A/C MAX mode off

- ▷ Press button **A/C MAX**.
The indicator light on the button goes out.
- or**
- Press button **AUTO/SYNC**.



Defrosting windshield

Activating defrosting function

- ▷ Press button .
The indicator light on the button lights up.
The air flows to the windshield and the front side windows.
The windshield is demisted or defrosted as quickly as possible.

Deactivating defrosting function

- ▷ Press button .
The indicator light on the button goes out.
- or**
- Press button **AUTO/SYNC**.

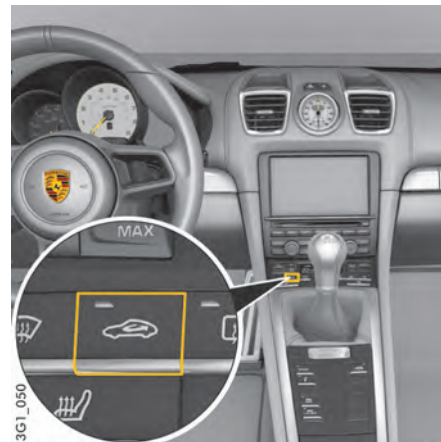

Air-recirculation mode

Switching on air-recirculation mode

- ▷ Press button .
The indicator light on the button lights up.
The outside-air supply is interrupted and only the inside air is recirculated.

Switching air-recirculation mode off

- ▷ Press button .
The indicator light on the button goes out.

Information

If the air-conditioning compressor is switched off manually or automatically, recirculated air mode ends after approx. 3 minutes.

Setting automatic air-recirculation mode

In automatic air-recirculation mode, the fresh air supply is adjusted depending on the air quality. Automatic air-recirculation mode can be switched on and off on the multi-function display. Air-recirculation mode is deactivated automatically to prevent the windows from misting at outside temperatures of less than approx. 41 °F (5 °C). For information on adjusting automatic air-recirculation mode on the multi-function display:

- ▷ Please see the chapter “SETTING AIR CONDITIONING” on page 104.

Information

The recommended operating mode is automatic air-recirculation mode (default setting).

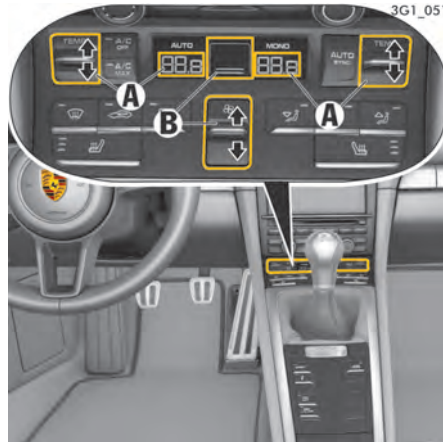

- A** - Set temperature left/right
- B** - Set air quantity

Setting temperature

For personal comfort, the interior temperature can be adjusted individually for the driver's and passenger's side between 61 °F (16 °C) and 85 °F (29.5 °C). Recommendation: 72 °F (22 °C). The selected temperature is shown on the display.

Increasing temperature

- ▷ Press button **TEMP** upwards.
The preset temperature value is shown on the air-conditioning display.

Information

Pressing button **AUTO/SYNC** selects the preset temperature.

Information

The air-conditioning system always cools and heats the passenger compartment to the preset temperature at maximum cooling or heating temperature.

Setting the temperature temporarily to a lower or higher value does **not** cool or heat the passenger compartment to the desired temperature more quickly.

Set air quantity

The selected air quantity is shown in a bar display above the button . The more bars that are displayed, the more air flows into the passenger compartment.

Increasing air quantity

- ▷ Press button  upwards.

Reducing air quantity

- ▷ Press button  downwards.

Pressing button **AUTO/SYNC** switches back to automatic mode.

If the air quantity was reduced so much that **OFF** appears on the air-conditioning display, the outside-air supply is interrupted and the air-conditioning compressor is switched off.

WARNING

Air shut-off impairing vision

The windows can mist up if the air quantity setting is **OFF**.

- ▷ Only select air quantity setting **OFF** for short periods.
- ▷ Press button  upwards (increase air quantity).



Setting air distribution manually

- ▷ Press button . The air flows to the windshield and the side windows.
- ▷ Press button . The air flows from the central and side vents. The air vents must be open.
- ▷ Press button . The air flows to the footwell.

The indicator light on the button lights up.

Cancelling manual air distribution

- ▷ Press the relevant air distribution button again. The indicator light on the button goes out.
or
Press button **AUTO/SYNC**. Air quantity and distribution are controlled automatically and variations are compensated.

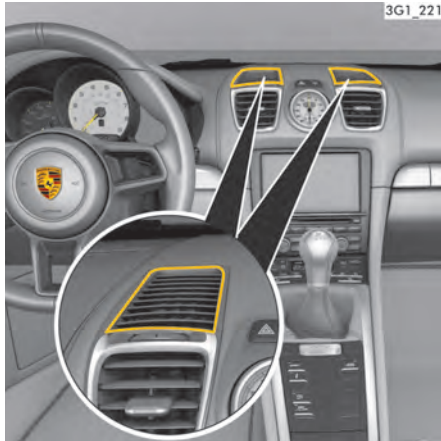

Extended ventilation panel

With the automatically controlled 2-zone airconditioning system, the extended ventilation panel on top of the dashboard can be activated or deactivated separately in the multi-function display on the instrument panel. The air flow in the passenger compartment is less direct. The automatic control of the air-conditioning system adjusts the air flow quantity automatically.

Air-conditioning settings on the multi-function display

With the automatically controlled 2-zone airconditioning system, additional settings relating to vehicle air conditioning can be adjusted in the multi-function display on the instrument panel.

For information on air-conditioning settings on the multi-function display:

- ▷ PLEASE SEE THE CHAPTER “SETTING AIR CONDITIONING” on page 104.

Air flow

Three air flow settings are available in automatic mode:

- **“Soft”**: Recommended for passengers sensitive to draughts with a preference for gentle air conditioning.
- **“Normal”**: Default setting.
- **“Strong”**: Stronger ventilation in the passenger compartment. The air flow is clearly noticeable.

Auto air-recirculation mode

- ▷ Auto air-recirculation mode can be switched on and off.



Air Vents

Air vents are located on the dashboard that can be opened and closed manually. The direction of the air flow can also be adjusted.

Opening vents

- ▷ Turn the thumb wheel on the air vent upwards.

Closing vents

- ▷ Turn the thumb wheel on the air vent downwards.

Information

- ▷ For optimal air conditioning, we recommend keeping the center air vents closed during the cold season and to only open them as required for the purpose of warming the hands.

Changing air flow direction

- ▷ Swivel vent vanes in the desired direction.



Heated Rear Window/ Exterior Mirror Heating

Heated rear window/exterior mirror heating is ready for operation when the engine is running.

Switching on

- ▷ Press button . The indicator light on the button lights up. Depending on the outside temperature, the heating switches off automatically after approx. 5 to 20 minutes.
- ▷ The heating can be switched back on by pressing the button again.

Switching off

- ▷ Press button . The indicator light on the button goes out. If the charging condition of the battery is critical, the heated rear window/exterior mirror heating function is restricted initially and then switched off.

Windows

Power Windows61

Power Windows

⚠ WARNING

Opening and closing the windows

When opening or closing the windows, particularly in one-touch mode, parts of the body may get trapped between the moving window and fixed vehicle parts.

- ▷ Take care to ensure that nobody can be injured when the windows open or close.
- ▷ Always remove the ignition key when leaving the vehicle or switch off the ignition on vehicles with Porsche Entry & Drive. Always take the ignition key with you when leaving the vehicle. Uninformed persons could injure themselves by operating the power windows.
- ▷ In case of danger, immediately release the button on the ignition key or the button in the door handle on vehicles with Porsche Entry & Drive.
- ▷ Do not leave children in the vehicle unattended.

Readiness for operation of power windows

The power windows are ready for operation:

- With ignition switched on.
 - After the ignition is switched off and before the driver's or passenger's door is first opened, but for a maximum of 10 minutes.
- One-touch operation for closing the door windows is available only when the ignition is switched on.

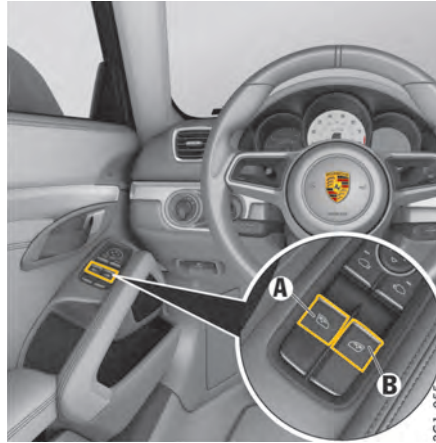

A - Power window, driver's side
B - Power window, passenger's side

Opening/closing windows

Opening window with the switch

- ▷ **Press the relevant switch** until the window has reached the desired position.

Closing window with the switch

- ▷ **Pull the relevant switch** until the window has reached the desired position.



Information

The switches have a two-stage function. Both detent positions can be felt clearly when you actuate the switch.

- **First setting – manual operation**

If the relevant switch is moved to the first position, the window is opened or closed manually.

The window stops when the switch is released.

- **Second setting – one-touch operation**

If the relevant switch is moved fully to the second position, the window is opened or closed automatically.

Actuate the switch again to stop the window at the desired position.



Information

If a door window is blocked during closing, it will stop and open again by several centimetres. If the window is blocked a second time within approx. 10 seconds, one-touch operation is disabled for this window.

The window can be closed manually. The window then closes with its full closing force.

One-touch operation is enabled again once the window has been closed completely using the manual closing function.

 **WARNING**

Closing the windows manually

If one-touch operation is disabled after the window is blocked, the window will close with its full closing force when the manual closing function is used.

- ▷ Ensure that nobody can be injured, pinched or crushed when the windows close.
-

Storing end position of the windows after connecting the vehicle battery

The end positions of the windows are lost when the battery is disconnected and reconnected.

One-touch operation of the windows is disabled.

Perform these steps for all windows:

1. Close window completely **once** by pulling the rocker switch.
2. When the window is completely closed, briefly pull the rocker switch again **three times**.
3. Open the window completely **once** by pressing the rocker switch.

Lights, Turn Signals and Windshield Wipers

Light Switch.....	64
Instrument Lighting	66
Turn Signal/High Beam/Headlight Flasher Stalk/Parking Light Switch.....	66
Emergency Flasher	67
Interior/Reading Lights	67
Brief Overview – Windshield wipers	69
Windshield Wiper/Washer Stalk	70

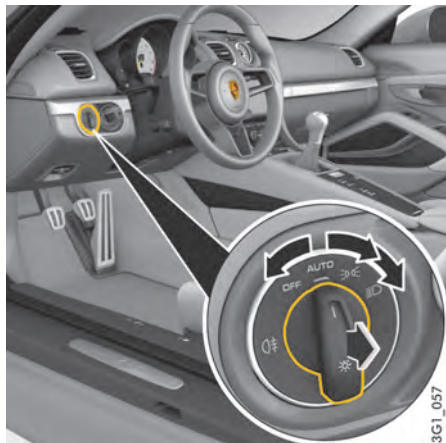

3G1_057

Light Switch

OFF Light is switched off

Daytime driving lights are switched on when the ignition is switched on.

AUTO Automatic driving light assistant

Side lights

License plate light, instrument lighting, daytime driving lights switched off.

Low beam/driving light

Only with ignition on.

Fog light function and highway light are switched off.

Rear fog light

Pull the switch in the low beam position. Indicator light lights up.

Information

If the ignition key is removed and the door is opened while the lights are on, an audible signal (gong) warns of possible battery discharge.

- In some countries, differences are possible due to legal requirements.

The vehicle's exterior lights can mist up due to temperature and humidity. This misting will dry off after a sufficient distance has been driven.

Low beam/driving light

If the light switch is set to the position **AUTO**, the low beam is switched on automatically in the following situations:

- Dusk
- Darkness
- Driving through tunnels
- Rain
- Highway driving (on vehicles with Porsche Dynamic Light System PDLS)

When the low beam is switched on, the indicator light on the speedometer lights up.

Information

Fog is not automatically recognized.

- ▷ In the event of fog, the driving light must be switched on manually.

Highway function in daylight

The driving light switches on automatically at speeds of more than approx. 140 km/h (90 mph) in bright conditions and when the daytime running lights are deactivated. When driving at a speed of less than approx. 65 km/h (40 mph), the driving light is switched off after a delay of approx. 4 min., provided the external lighting conditions permit.

Daytime driving lights

If the light switch is set to position **OFF** (light off), the daytime driving lights come on automatically when the ignition is switched on.

If the light switch is set to position **AUTO**, the daytime driving lights come on automatically in bright conditions and when the ignition is switched on.

The daytime driving lights are not active when the light switch is set to position  (low beam/driving light).

Automatic driving light assistant

The automatic driving light assistant is a comfort function. The driving light (low beam) is switched on and off automatically depending on the ambient brightness.

The automatic driving light assistant also controls the daytime driving lights, low beam, Automatic Coming Home lights and the equipment-dependent dynamic cornering light.

The automatic driving light assistant is activated when the light switch is set to the position **AUTO**. Despite possible support by the driving light assistant, it is the responsibility of the driver to switch on the driving light using the conventional light switch in accordance with the relevant national regulations.

Activating the headlights using the driving light assistant therefore does not absolve the driver of responsibility for correct operation of the driving light.

⚠ WARNING

Driving without lights

If you drive without lights, this may significantly restrict your visibility and also the ability of other road users to see your vehicle.

- ▷ Always carefully monitor the automatic driving light control.

**Information**

In the event of a fault in the automatic driving light assistant/Porsche Dynamic Light System (PDLS), the PDLS warning light in the instrument panel flashes.

For information on indicator lights and warning lights on the instrument panel:

- ▷ Please see the chapter “INSTRUMENT PANEL USA MODELS” on page 74.
- ▷ Please see the chapter “OVERVIEW OF WARNING AND INFORMATION MESSAGES” on page 109.

Rain function

The driving light is switched on automatically after five seconds of continuous wiper operation.

If the wipers have not been used for approx. 4 minutes, the driving light is switched off.

Automatic Coming Home lights (Welcome Home function/Entry function)**Switching on Automatic Coming Home lights**

- ▷ Set light switch to **AUTO** .

The following lights remain switched on for a certain period to allow you to get in and out of your vehicle safely and with improved visibility in darkness:

- Daytime driving lights,
- Courtesy lights in the folded out exterior mirrors (on vehicles with electrically foldable mirrors),
- Rear side marker lights,
- License plate lights.

Welcome Home function (off delay)

When the vehicle is locked, the lights remain switched on for the duration of the off delay preset on the multi-function display.

For information on adjusting the off delay of the external lights on the multi-function display:

- ▷ Please see the chapter “ADJUSTING EXTERIOR LIGHTS” on page 102.

Entry function/Exit function

When the vehicle is unlocked, the area around the vehicle is illuminated for the duration of the off delay preset on the multi-function display.

The lights are switched off when the ignition is switched on or the light switch is set to a position other than **AUTO** .

For information on adjusting the off delay of the external lights on the multi-function display:

- ▷ PLEASE SEE THE CHAPTER “ADJUSTING EXTERIOR LIGHTS” on page 102.

Porsche Dynamic Light System (PDLS)

The dynamic cornering light as well as the highway function in darkness are activated when the light switch is set to the position **AUTO** .

Dynamic cornering light

Above a speed of approx. 5 mph (8 km/h), the low beam light is swiveled in the direction of the curve to illuminate the road more clearly, depending on the speed of the vehicle and the extent to which the steering wheel is turned.

In the event of a fault in the dynamic cornering light, the PDLS warning light in the instrument panel flashes.

Highway function in darkness

The distribution characteristics of the driving light change when driving in darkness at vehicle speeds above approx. 80 mph (130 km/h).

The light beam becomes longer and the field of vision increases.

Fog lights

The distribution characteristics of the driving light change when the rear fog light is switched on at vehicle speeds below approx. 43 mph (70 km/h). The light beam becomes wider and reduces glare.



Instrument Lighting

The lighting is automatically adjusted to the ambient brightness via light sensors. In addition, when the vehicle lighting is switched on, the instrument and switch brightness can be adjusted manually.

- ▷ Turn adjustment button **A** in the appropriate direction and hold until the desired brightness has been reached.



WARNING

Adjusting the brightness while driving

Adjusting the brightness while driving may cause you to lose control of the vehicle.

- ▷ Do not reach through the steering-wheel spokes while driving.



Turn Signal/High Beam/Headlight Flasher Stalk/Parking Light Switch

Turn signals, low beam and high beam are ready for operation when the ignition is on.

- 1 – Turn signal light, left**
- 2 – Turn signal light, right**
- 3 – High beam**
- 4 – Headlight flasher**

Stalk in center position – low beam

Operating the turn signal light

- ▷ Push the stalk past the lower or upper pressure point **1** or **2**.
The turn signal lights stay on until the stalk is moved back to its initial position either manually or automatically as a result of turning the steering wheel.
- ▷ Push the stalk once to the lower or upper pressure point **1** or **2**.
The turn signal lights flash three times.

High-beam headlight

Switching on and off

- ▷ **Switching on:** Push the stalk once to the front pressure point **3**.
The indicator light  lights up on the tachometer.
- ▷ **Switching off:** Push the stalk once to the rear pressure point **4**.

Operating the headlight flasher

- ▷ Push the stalk once to the rear pressure point **4**.
The indicator light  on the tachometer lights up briefly.

Parking light

The parking light can only be switched on when the ignition is switched off.

- ▷ Move the stalk up **2** or down **1** to switch on the right or left parking light.

If the parking light is switched on, the message **“Parking light on”** will appear on the multi-function display in the instrument panel after the ignition is switched off.

For information on warning messages on the multi-function display:

- ▷ Please see the chapter **“OVERVIEW OF WARNING AND INFORMATION MESSAGES”** on page 109.

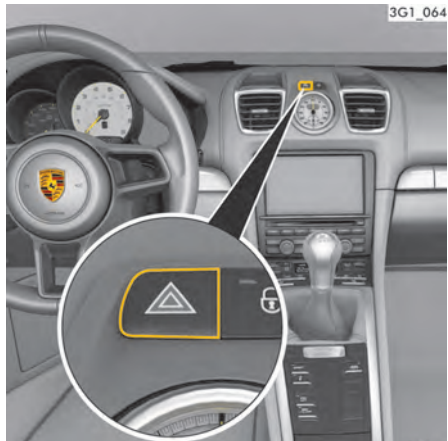

Emergency Flasher

The emergency flasher can be switched on regardless of the position of the ignition lock.

Switching on and off

- ▷ Press the emergency flasher button on the dashboard.

All turn signal lights and the indicator light in the button flash when the button is operated.

If the emergency flasher remains active for longer periods, the illumination phase of the flashing interval is shortened to preserve the lights.

⚠ DANGER

Emergency stopping

Other vehicles could collide with your vehicle if you are parked in a dangerous position.

- ▷ Whenever stalled or stopped for emergency repairs, move the car well off the road. Switch on the emergency flasher and mark the car with road flares or other warning devices.
- ▷ Do not remain in the car. Someone approaching from the rear may not realize your vehicle is stopped and cause a collision.

⚠ WARNING

Hot exhaust system and tailpipe

Exhaust fumes and the exhaust system are very hot when the engine is running. The exhaust system (including the tailpipe) remains hot for some time after the vehicle is turned off.

- ▷ Do not park or operate the vehicle in areas where the hot exhaust system may come in contact with dry grass, brush, fuel spill or other flammable material.

⚠ WARNING

Engine heat danger when working

The engine and surrounding components become very hot when the engine is running.

- ▷ Before working on any part in the engine compartment, turn the engine off and let it cool down sufficiently.

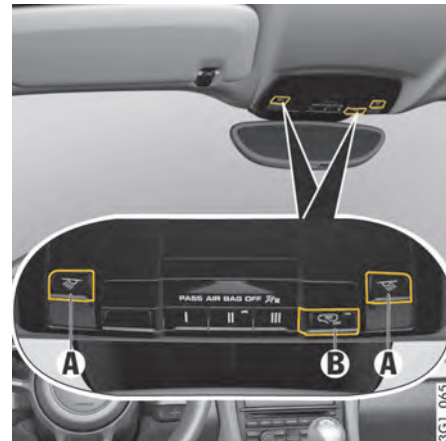

A - Button for interior/reading lights

B - Switching automatic interior/reading lights on/off

Interior/Reading Lights

Interior/reading lights

Switching interior/reading lights on and off

- ▷ Press button **A**.

Dimming (brightness adjustment)

- ▷ Press button **A** for at least 1 second and hold until the desired level of brightness is achieved.

Switching automatic interior/reading lights on and off

Depending on equipment, the interior/reading lights can be switched on and off using **button B** or in the **multi-function display** menu.

Using button “B”:

▷ Press button **B**.

When automatic interior/reading lights are switched off, the indicator light in the button lights up.

When the automatic interior lighting is switched on in darkness, the interior lighting is

- **switched on:** when a door is unlocked or opened, or when the ignition key is removed from the ignition lock.
- **switched off:** when both doors have been closed, after a delay of approx. 120 seconds. The off delay time can be preset on the multi-function display.
The interior lighting goes out as soon as the ignition is switched on or the vehicle is locked.

▷ Please see the chapter “SETTING INTERIOR LIGHTING OFF DELAY” on page 103.

In the multi-function display menu:

On the multi-function display, you can set whether the interior/reading lights should be switched on or remain switched off when a door is unlocked or opened or when the ignition key is removed from the ignition lock:

▷ Please see the chapter “ACTIVATING OR DEACTIVATING INTERIOR LIGHTS WHEN THE DOOR IS OPENED (DEPENDING ON EQUIPMENT)” on page 103.

The off delay for the interior/reading lights when both doors are closed can be set on the multifunction display:

▷ Please see the chapter “SETTING INTERIOR LIGHTING OFF DELAY” on page 103.

Switching off of interior/reading lights to protect the battery

In darkness, the interior lighting is switched off 16 minutes after the engine stops to preserve the vehicle battery.

In daylight conditions, interior lights that were switched on manually are switched off automatically after 1 minute.

Orientation lighting

Lights in the overhead operating console and at the ignition lock help vehicle occupants to locate important controls in the vehicle in darkness and ensure better overall orientation. The lights are switched on when the vehicle is unlocked and switched off again automatically when the vehicle is locked.

Dimming (brightness adjustment)

The brightness of the orientation lighting is adjusted on the multi-function display.

▷ Please see the chapter “ADJUSTING BRIGHTNESS OF ORIENTATION LIGHTING” on page 103.

Ambient lighting

If the vehicle is driven at night, a discreet light provides subtle illumination for the passenger compartment. The ambient lighting is switched off automatically when the vehicle is locked.

Brief Overview – Windshield wipers

This brief overview does not replace the information provided under “WINDSHIELD WIPER/WASHER STALK”.

Warnings, in particular, are not replaced by this brief overview.



Windshield wiper stalk



Switch for rain sensor sensitivity (A)

What do I want to do?	What do I have to do?
Wipe automatically at front (rain sensor operation)	Press the stalk to detent position 1 .
Adjusting the rain sensor operation sensitivity	Adjust switch A on the right of the stalk upwards (wipe more often) or downwards (wipe less often).
Wipe at front	Slow: Press the stalk to detent position 2 . Fast: Press the stalk to detent position 3 . Once: Briefly move stalk to position 4 (holding stalk in position 4 accelerates wiping action).
Spray and wipe at front	Pull stalk towards the steering wheel at position 5 and hold.

Windshield Wiper/Washer Stalk

CAUTION

Cleaning windshield

In rain sensor operation, the windshield wipers wipe automatically if moisture is detected on the windshield.

- ▷ Always switch off windshield wipers before cleaning the windshield to avoid unintentional operation (rain sensor operation).

NOTICE

Risk of damage to the luggage compartment lids, windshield, rear window and wiper system.

- ▷ Only wipe the windshield when sufficiently wet, otherwise it could become scratched.
- ▷ Loosen frozen wiper blades before starting to drive.
- ▷ Do not operate a frozen headlight washer system.
- ▷ Always switch off windshield wipers in car washes to prevent them wiping unintentionally (rain sensor operation).
- ▷ Do not operate headlight washer system in car washes.
- ▷ Always switch off windshield wipers before cleaning the windshield to avoid unintentional operation (rain sensor operation).
- ▷ Always hold the wiper arm securely when replacing the wiper blade.
- ▷ Always switch off windshield wipers before opening the luggage compartment lids (wiper switch in position **0**).
- ▷ When replacing wiper blades, observe different lengths of the wiper blades.



Windshield wiper and headlight washer system

0 – Windshield wipers off

When the windshield wipers are switched off and also occasionally after the ignition is switched off, the wipers move up slightly from their rest position so that the wiping edges are aligned correctly.

1 – Rain sensor operation, Windshield wipers

- ▷ Press the wiper stalk upwards to the first click.

2 – Windshield wipers – slow

- ▷ Press the wiper stalk upwards to the second click.

3 – Windshield wipers – fast

- ▷ Press the wiper stalk upwards to the third click.

4 – One-touch operation Windshield wipers

- ▷ Press the wiper stalk downwards. The windshield wipers carry out one wiping cycle.

5 – Windshield wiper and washer system

- ▷ Pull wiper stalk towards the steering wheel. The system wipes as long as the stalk is pulled towards the steering wheel. When the wiper stalk is released, a few drying wipes are performed. After every 10 wipes on the windshield, the headlights are cleaned automatically.



Information

- ▷ If heavily soiled, repeat wash.
- ▷ Persistent dirt (e.g. insect residues) should be removed regularly.

For information on car care:

- ▷ Please see the chapter “CAR CARE INSTRUCTIONS” on page 174.

Windshield wiper blades that are in perfect condition are vital for a clear view.

- ▷ Please see the chapter “WIPER BLADES” on page 168.

Fitting ice or sun shields and wiper blade replacement

- ▷ After switching off the ignition, press the wiper stalk once downwards **4**. The wipers move upwards to an angle of approx. 45°.



Rain sensor operation, windshield wipers

In rain sensor mode, the amount of rain on the windshield is measured. The wipe interval is automatically controlled accordingly.

Rain sensor operation is activated automatically at speeds of less than approx. 2.5 mph (4 km/h) when the windshield wipers are switched on. If a speed of approx. 5 mph (8 km/h) is exceeded, the system switches to the preselected wiper speed.

i Information

- ▷ If the wiper stalk is in position 1 when the ignition is switched on, the rain sensor is activated as soon as the vehicle speed exceeds approx. 2.5 mph (4 km/h).
- ▷ If the wiper stalk is in position 2 or 3 when the ignition is switched on, the windshield wipers remain switched off until the wiper stalk is actuated.

i Information

The wiper is stopped when the luggage compartment lid is opened.

After closing the luggage compartment lid, the wiper stalk must be operated in order to switch the wiper back on.

Adjusting the rain sensor sensitivity

- ▷ Move switch **A** upwards – **high sensitivity**.
The setting is confirmed by one wipe of the windshield.
- ▷ Move switch **A** downwards – **low sensitivity**.

Activating and deactivating automatic rain sensor operation in the multi-function display

For information on automatic rain sensor operation:

- ▷ Please see the chapter "ACTIVATING AND DEACTIVATING RAIN SENSOR OPERATION" on page 103.



Headlight washer system

(on vehicles with Bi-Xenon™ headlights and PDLS)

The washer sprays only while low beam or high beam is activated.

- ▷ Press button **B** under the wiper stalk.
After every 10 wipes on the windshield, the headlights are cleaned automatically as well. The wipe count starts from zero again when the low beam is switched off.



Information

- ▷ Clean the wiper blades with window cleaner at regular intervals, especially after washing the vehicle in a car wash.
We recommend Porsche window cleaner.
If the wiper blades are very dirty (e.g. soiled with insect remains), they can be cleaned with a sponge or cloth.

If the wiper blades judder or squeak, this may be due to the following:

- If the vehicle is washed in an automatic car wash, wax residues may adhere to the windshield. These wax residues can be removed only by using window cleaner concentrate.

Please see the chapter “WASHER FLUID” on page 167.

- The wiper blades may be damaged or worn.
- ▷ Replace damaged wiper blades immediately.
 - ▷ Contact an authorized Porsche dealer for more information.
-

Instrument Panel and Multi-Function Display

Instrument Panel USA Models.....	74
Instrument Panel Canada Models.....	75
Displays on the Instrument Panel.....	76
Battery/Alternator	77
Check Engine (Emission Control)	77
Acoustic Signals	77
Operating the Multi-Function Display on the Instrument Panel	78
Vehicle Menu	81
Audio Menu.....	83
Phone Menu.....	84
Map Menu	84
Navigation Menu	85
Trip Menu	86
Tire Pressure Menu (Tire Pressure Monitoring System, TPMS)	86
Chrono Menu (Stopwatch).....	95
Gear Shift Assist Menu	97
G-Forces Menu.....	98
Performance Menu.....	98
Vehicle Settings on the Multi-Function Display	99
Overview of Warning and Information Messages.....	109



Instrument Panel USA Models

A Speedometer

B Tachometer

C Multi-function display

For information on warning and information messages of the multifunction display on the instrument panel:

- ▷ Please see the chapter "OVERVIEW OF WARNING AND INFORMATION MESSAGES" on page 109.

D Reset button for trip counter display/
brightness setting for instrument panel

E Odometer

F Digital speedometer











G Upshift indicator

H Gear display







I Marking showing position of filler flap

J Fuel gauge

Warning and indicator lights on the tachometer

-  Emission control warning light (Check Engine)
-  Airbag warning light
-  Safety belt warning light
-  PSM warning light
-  PSM OFF warning light
-  ABS warning light
-  Turn signal, left
-  Turn signal, right
-  BRAKE Brake warning light
-  High beam indicator light
-  Electric parking brake warning light

Warning and indicator lights on the speedometer

-  Rear fog light indicator light
-  HOLD HOLD function indicator light
-  Low beam indicator light
-  PDLs warning light
-  TC OFF TC OFF warning light
-  Tire pressure warning light

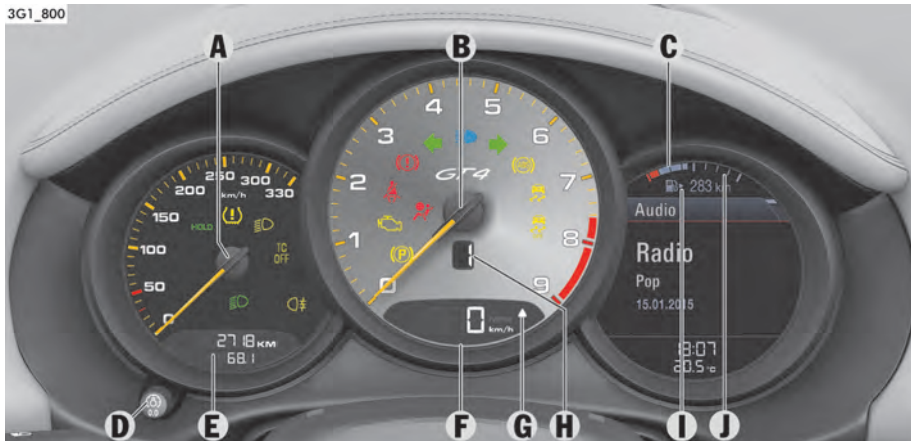

Instrument Panel Canada Models

A Speedometer

B Tachometer

Multi-function display

C Reset button for trip counter display/
brightness setting for instrument panel

D Odometer

E Digital speedometer

F Upshift indicator

G Gear display











H Marking showing position of filler flap

I Fuel gauge



For information on warning and information messages of the multifunction display on the instrument panel:

- ▷ Please see the chapter "OVERVIEW OF WARNING AND INFORMATION MESSAGES" on page 109.

Warning and indicator lights on the tachometer

-  Emission control warning light (Check Engine)
-  Airbag warning light
-  Safety belt warning light
-  PSM warning light
-  PSM OFF warning light
-  ABS warning light
-  Turn signal, left
-  Turn signal, right
-  Brake warning light
-  High beam indicator light
-  Electric parking brake warning light

Warning and indicator lights on the speedometer

-  Rear fog light indicator light
-  HOLD function indicator light
-  Low beam indicator light
-  PDL warning light
-  TC OFF warning light
-  Tire pressure warning light

Displays on the Instrument Panel

A – Speedometer

The analogue display **A** is located on the left next to the tachometer in the instrument panel.

B – Tachometer

The start of the red zone on the tachometer or rev-counter scale is a visual warning of the maximum permissible engine speed.

If the red zone is reached during acceleration, fuel feed is interrupted in order to protect the engine.

C – Multi-function display

For information on the multi-function display:

- ▷ Please see the chapter “OPERATING THE MULTI-FUNCTION DISPLAY ON THE INSTRUMENT PANEL” on page 78.

D – Reset button for trip counter display/ brightness setting for instrument lighting

Resetting trip counter display

- ▷ Press rotary switch **D** for approx. 1 second. The trip counter display is reset to “0”.

Adjusting brightness of instrument lighting

For information on adjusting the brightness of the instrument lighting:

- ▷ Please see the chapter “ADJUSTING INTERIOR LIGHTS” on page 103.

E – Odometer

The displays for the total mileage and individual trips are integrated in the speedometer on the instrument panel.

The upper display counts the total mileage, the lower display shows individual trips.

After exceeding 6,213 miles or 9,999 kilometers, the trip counter returns to 0.

F – Digital speedometer

The digital speedometer **F** is integrated in the tachometer on the instrument panel.

G – Upshift indicator

The consumption-oriented shift indicator to the right of the digital speed display on the tachometer helps you to develop a fuel-saving driving style.

The upshift indicator lights up - prompting you to shift up to the next-higher gear - depending on the selected gear, engine speed and accelerator pedal position.

- ▷ Change to the next-higher gear when the upshift indicator lights up.

H – manual transmission gear display

When the engine is running, the display shows the currently engaged gear.

J – Fuel gauge

The fuel gauge displays the contents of the tank, and depending on the settings, the fuel range when the ignition is on.

For information on adjusting the fuel gauge:

- ▷ Please see the chapter “ADAPTING FUEL GAUGE” on page 102.

For information on fuel quality and refill capacities:

- ▷ Please see the chapter “FILLING CAPACITIES” on page 223.

For information on fuel and refueling:

- ▷ Please see the chapter “FUEL” on page 171.

If the vehicle's inclination changes (e.g. uphill/downhill driving), minor deviations in the gauge may occur.

Fuel reserve warning

If less than approximately 2.6 U.S. gallons (10 liters) remains in the tank, the warning light on the multi-function display lights up when the ignition is switched on or the engine is running.

- ▷ Refuel at the next opportunity.

NOTICE

A shortage of fuel may damage the emission control system.

- ▷ Never drive the tank dry.
- ▷ If the warning lights have come on, do not take bends at high speed.

For information on the emission control system:

- ▷ Please see the chapter “EMISSION CONTROL SYSTEM” on page 168.

Battery/Alternator



Warning message

The warning message “**Generator fault Park vehicle safely**” will appear on the multi-function display in the instrument panel if the vehicle electrical system voltage drops significantly.

▷ Stop at a safe place and switch the engine off.

For information on warning messages on the multi-function display:

▷ Please see the chapter “OVERVIEW OF WARNING AND INFORMATION MESSAGES” on page 109.

Possible causes

- Defect in the battery charging system
- Broken drive belt

NOTICE

Risk of engine damage.

The engine cooling does not function if the drive belt is torn.

- ▷ Do not continue driving.
- ▷ Have the fault corrected.
- ▷ Please contact a qualified specialist workshop. We recommend that you get an authorized Porsche dealer to do this work as they have trained workshop personnel and the necessary parts and tools.

Check Engine (Emission Control)



Warning light

The emission control system detects malfunctions that could cause increased pollutant emissions or consequential damage, etc. well in advance.

Faults are indicated by the warning light on the instrument panel which then either lights up continuously or flashes.

The faults are recorded in the control unit's fault memory.

The warning light on the instrument panel lights up when the ignition is switched on as a lamp check and goes out approx. 1 second after the engine starts.

The warning light on the instrument panel flashes to indicate operating states (e.g. engine misfiring) which may cause damage to certain parts of the emission control system.

▷ In this case, immediately reduce the engine load by easing off the accelerator pedal.

In order to avoid consequential damage to the engine or the exhaust-gas cleaning system (e.g. catalytic converter):

▷ We recommend that you get an authorized Porsche dealer to do this work as they have trained workshop personnel and the necessary parts and tools.

NOTICE

Risk of damage to the emission control system. If the warning light on the instrument panel continues flashing even when you have eased off the accelerator pedal, the emission control system may overheat.

- ▷ Stop as soon as possible in a safe place. Make sure that combustible materials, such as dry grass or leaves, cannot come into contact with the hot exhaust system.
- ▷ Switch off the engine.
- ▷ Have the fault corrected.

Acoustic Signals

A speaker in the instrument panel generates acoustic signals.

The warning message “**Instrument cluster/ Park Assist audio fault Service required**” will appear on the multi-function display in the instrument panel if a speaker fault occurs.

The speaker cannot generate acoustic signals.

▷ Please see the chapter “OVERVIEW OF WARNING AND INFORMATION MESSAGES” on page 109.

Operating the Multi-Function Display on the Instrument Panel

On the multi-function display, you can view information relating to the relevant vehicle equipment, operate the audio source (radio, CD, iPod, etc.), check the oil level, check the tire pressure, use the stopwatch or operate the navigation system.

You can also modify different vehicle settings in the **"Vehicle"** menu.

It is not possible to describe all details of the functions in this Owner's Manual. The examples clearly demonstrate the functional principle and clarify the menu structure.

WARNING

Operation of the multi-function display, radio, navigation system, telephone etc. during driving.

You may be distracted from paying attention to the road if you set or operate the multi-function display, radio, navigation system, telephone or other equipment when driving. You may lose control of the vehicle.

- ▷ Operate the equipment while driving only if the traffic situation allows you to do so safely.
- ▷ Carry out any complicated operating or setting procedures only while the vehicle is stationary.



Multi-function display

Information

The multi-function display is only active when the ignition is on. Certain menus are only available when the vehicle has stopped, e.g. the adjustment menu for tire pressure monitoring system.



Operating principle

The multi-function display is operated with the lower lever on the right of the steering column.

Selecting menu, function, setting option

- ▷ Push the lever downwards (position **3**) or upwards (position **4**).

Confirming selection (Enter)

- ▷ Push the lever forward (position **1**).

Moving back one or several selection levels

- ▷ Pull the lever towards the steering wheel (position **2**) once or several times.



- A - Fuel gauge
- B - Title area with menu indicator
- C - Information area
- D - Status area

Areas on the multi-function display

A – Fuel gauge

The fuel gauge **A** displays the contents of the tank, and depending on the settings, the fuel range when the ignition is on.

For information on adjusting the fuel gauge:

- ▷ Please see the chapter “ADAPTING FUEL GAUGE” on page 102.

For information on fuel quality and refill capacities:

- ▷ Please see the chapter “FILLING CAPACITIES” on page 223.

For information on fuel and refueling:

- ▷ Please see the chapter “FUEL” on page 171.

If the vehicle's inclination changes (e.g. uphill/downhill driving), minor deviations in the gauge may occur.

Fuel reserve warning

If less than approximately 2.6 U.S. gallons (10 liters) remain in the tank, the warning light on the multi-function display lights up when the ignition is switched on or the engine is running.

- ▷ Refuel at the next opportunity.

NOTICE

A shortage of fuel may damage the emission control system.

- ▷ Never drive the tank dry.
- ▷ If the warning lights have come on, do not take bends at high speed.

For information on the emission control system:

- ▷ Please see the chapter “CAR CARE INSTRUCTIONS” on page 174.

B – Title area with menu indicator

The menu item currently selected is displayed in the title area **B**.

The menu indicator (gray bar) on the right shows the position of the current menu item in the overall menu and displays the number of other menu items on this menu level.

The wider the menu indicator, the fewer menu items the current menu contains.

C – Information area

The information area **C** displays the menu items currently available for selection or after a menu item is selected, information relating to this menu item or other selection options.

D – Status area

Basic information, such as time and temperature, as well as warnings are displayed in the status area **D**.

The display contents of the status area can be individually adapted.

For information on adapting the multi-function display:

- ▷ Please see the chapter “ADAPTING APPEARANCE OF MULTI-FUNCTION DISPLAY” on page 99.

Activating functions, opening submenus and accessing setting options from the main menu areas

Push the right lower lever on the steering wheel forwards (position **1**) to access menus, other functions and setting options regardless of the main menu area.

1. Select main menu and confirm.
2. Select function, submenu or setting option and confirm.

Browsing through long lists

When searching for an entry in long telephone and audio lists on vehicles with PCM, you can skip directly to other entries with the same first letter.

- ▷ Hold the control stalk in position **3** or **4**.

A letter selection screen appears.

Select the desired first letter and confirm.

The marking skips to the first list entry beginning with the letter selected.

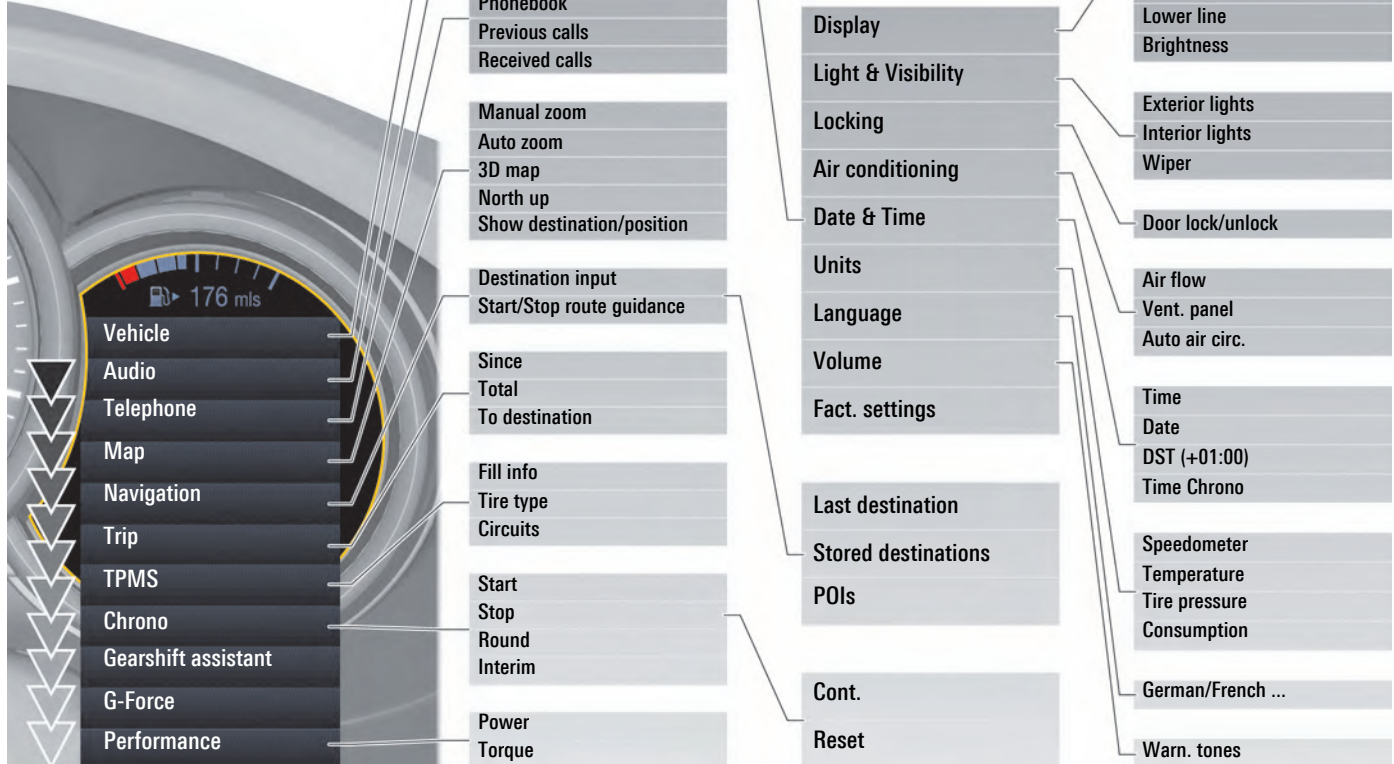

Vehicle Menu

A large amount of vehicle information can be displayed and vehicle settings made in the **“Vehicle”** main menu.

1. Select **“Vehicle”** main menu.

The vehicle information display can be adapted individually.

For information on adapting the vehicle menu:

- ▷ Please see the chapter **“ADAPTING DISPLAY CONTENTS IN VEHICLE INFORMATION AREA”** on page 99.

Displaying vehicle information

Pending warning messages, information on forthcoming service intervals and the average fuel consumption can be viewed in the **“Info”** sub-menu of the **“Vehicle”** main menu area.

1. Main menu: Select **“Vehicle”** > **“Info”** and confirm.



Displaying messages

All current warning messages and vehicle messages can be viewed on the multi-function display.

The warning symbol in the lower status area indicates the number of pending warning messages.

If several warning messages are pending, you can browse through the message list.

1. Main menu **“Vehicle”** > **“Info”**
2. Select **“Messages”** and confirm.

Displaying service intervals

The internal mileage counter indicates when the next vehicle service is due.

1. Main menu **“Vehicle”** > **“Info”**
2. Select **“Service intervals”** and confirm.
3. Select the desired service interval and confirm.

Available service interval displays:

- **“Service”**
- **“Interm. service”**
- **“Oil change”**

Display and measurement of the engine oil level

NOTICE

Risk of engine damage due to inadequate lubrication.

- ▷ Regularly check the oil level each time before refuelling.
- ▷ Do not allow the oil level to fall below the minimum mark.

Prerequisites for the oil-level gauge:

1. Park the vehicle on a level surface.
2. Switch off engine, which is now at operating temperature.
3. Wait for approx. 1 minute.
4. Select the **“Oil measurement”** function on the multi-function display.

Selecting the Oil measurement function on the multi-function display

1. Main menu: Select **“Vehicle”**
> **“Oil measurement”**
and confirm.

- ▷ Please see the chapter **“OVERVIEW OF WARNING AND INFORMATION MESSAGES”** on page 109.

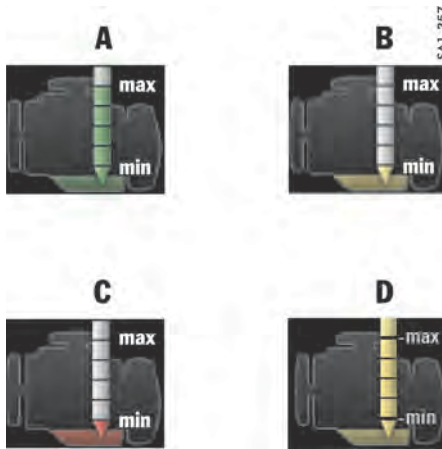

Example displays for oil level
A - Maximum oil level reached
B - Minimum oil level reached
C - Oil level below minimum
D - Oil level above maximum

Measured oil level

The oil level reading is shown on the segment display in the Oil measurement menu.

If the segments are filled in green up to the top line (illustration **A**), the oil level has reached the maximum mark.

- ▷ Under no circumstances add engine oil.

If the bottom segment is shown in yellow (illustration **B**), the oil level has reached the minimum mark.

The message **“Oil level minimum reached Refill oil”** appears on the multi-function display.

- ▷ Add engine oil immediately.

If the bottom segment is red (illustration **C**), the oil level has dropped below the minimum mark.

The message **“Oil level below min. Refill oil at once Do not drive on”** appears on the multi-function display.

- ▷ Add engine oil immediately.

Top-up quantity

The difference between the minimum and maximum marks on the segment display is approx. 1.8 quarts (1.7 liters).

- ▷ Never add more engine oil than required to reach the maximum mark.

If the segments are shown in yellow up to the top edge (illustration **D**), this indicates that the maximum engine filling capacity has been exceeded. Exceeding the maximum capacity may result in blue smoke formation and cause long-term damage to the catalytic converters depending on the overfill quantity and various external influences.

If too much engine oil was added, the message **“Oil level above maximum Consult a workshop Driving permitted”** appears on the multi-function display.

- ▷ Have the oil quantity corrected at the next opportunity.
Please contact an authorized Porsche dealer.

Measuring the oil level after topping up engine oil or opening the rear lid

The oil level can be checked after waiting for approx. 1 minute with the vehicle parked on a level surface and the engine at operating temperature. If the rear lid is opened when the engine is cold (e.g. in order to top up engine oil), the oil level cannot be displayed for a certain time.

The message **"No inform./oil level available now"** appears on the multi-function display.

- ▷ Engine oil should therefore only be topped up with the engine at operating temperature. This ensures short waiting times for the soonest possible oil level display.

Failure

If the oil-level indicator fails, the message **"Oil level measurement fault Consult a workshop Driving permitted"** appears on the multi-function display.

Setting speed limits

If a speed limit is preset and activated on the multi-function display, a warning message appears if the speed limit is exceeded.

A speed limit can be used to remind the driver to keep to the maximum speed permitted for the tire fitted to the vehicle, for example.

1. Main menu: Select **"Vehicle"** > **"Limits"** and confirm

Setting a speed limit

1. Main menu **"Vehicle"** > **"Limits"**
2. Select **"Limit 1: ---"** or **"Limit 2: ---"** and confirm.
3. Select **"Current speed"** or **"---"** and confirm.

You can either adopt the current speed of the vehicle or specify your own speed limit.

Activating and deactivating speed limits

1. Main menu **"Vehicle"** > **"Limits"**
2. Select **"Limit 1: ---"** or **"Limit 2: ---"** and confirm.
3. Select **"Active"**
4. Confirm your selection.
 Limit is active.
 Limit is not active.

Adjusting vehicle settings

Various vehicle settings can be modified in the **"Settings"** submenu.

- For information on modifying vehicle settings:
- ▷ Please see the chapter "PERFORMANCE MENU" on page 98.

Audio Menu

In the **"Audio"** main menu, you can select a radio station either from the station list or the list of stored stations, depending on the settings, or a track from the active audio source, e.g. disc.

1. Main menu: Select **"Audio"** and confirm.
2. Select the desired radio station or track and confirm.

For information on adjusting audio menu settings:

- ▷ Please see the chapter "ADAPTING DISPLAY CONTENTS OF AUDIO MAIN MENU" on page 99.

Phone Menu

In the **“Phone”** main menu, you can retrieve telephone numbers stored in the phonebook or in lists of most recently dialed or received calls.

1. Main menu: Select **“Phone”** and confirm.

Dialling telephone number

1. Main menu **“Phone”**
2. Select **“Phonebook”** or **“Previous calls”** or **“Received calls”** and confirm.
3. Select the desired telephone number and confirm.

Answering calls

1. Main menu **“Phone”**
2. Select **“Answer”** and confirm.

Rejecting calls

1. Main menu **“Phone”**
2. Select **“Reject”** and confirm.

Ending a call

1. Main menu **“Phone”**
2. Select **“End call”** and confirm.

Making multiple calls simultaneously

During an active telephone conversation, you have the option of starting another telephone conversation.

You can have a separate conversation with the person you have called or alternatively start a conference call together with the other caller.

Making additional calls

During a current call:

1. Main menu **“Phone”**
2. Select **“New call”** and confirm.

Switching between callers

1. Main menu **“Phone”**
2. Select **“Swap”** and confirm.

Adding a caller to a conference call

1. Main menu **“Phone”**
2. Select **“Conference”** and confirm.

Map Menu

In the **“Map”** main menu, you can view and modify the map display of the navigation system.

1. Main menu: Select **“Map”**.

Modifying map display

1. Main menu: Select **“Map”** and confirm.
2. Select display option and confirm.
3. Confirm your selection.

- Function is active.
- Function is not active.

Available display options:

- **“Auto zoom”**
The scale of the map is set automatically from the current position of the vehicle to the next navigation maneuver point.
- **“3D map”**
Three-dimensional map display.
- **“North up”**
The map always faces north.

Enlarging and reducing map display

The zoom factor of the map display can be adapted individually.

1. Main menu: Select **“Map”**
> **“Manual zoom”**
and confirm.

2. Select the desired zoom setting
and confirm.

Displaying current location or destination

You can view the navigation destination or current vehicle position on an enlarged section of the map.

1. Main menu **“Map”**
2. Select
“Show destination” or
“Show position”
and confirm.

Navigation Menu

In the **“Navigation”** main menu, you can enter a navigation destination, start route guidance and view the navigation information for an active route.

1. Main menu: Select **“Navigation”**
and confirm.

Entering navigation destination

You can enter a navigation destination in the multi-function display.

Only navigation destinations from the list of previous destinations or from the list of preset POIs or stored destinations can be selected.

1. Main menu **“Navigation”**
> **“Destination input”**
2. Select
“Last destination” or
“Stored destination” or
“POIs”
and confirm.
3. Select the desired navigation destination
and confirm.

Starting route guidance

If route guidance is inactive and you have entered a new navigation destination you can then start route guidance.

1. Main menu **“Navigation”**
2. Select **“Start route guidance”**
and confirm.

Stopping route guidance

You can stop route guidance while in progress.

1. Main menu **“Navigation”**
2. Select **“Stop route guidance”**
and confirm.



Trip Menu

In the **“Trip”** main menu, you can retrieve and reset driving data.

1. Main menu:
Select **“Trip”**.

Displaying driving data

There are three driving data displays available.

1. Main menu **“Trip”**.
2. Select
“1 – Since” or
“2 – Total” or
“3 – To destination”
and confirm.

Available driving data:

- **“Since”**
Driving data since the last vehicle start.
The driving data is reset automatically once the vehicle has remained stationary for 2 hours (with the ignition switched off).
- **“Total”**
Cumulative driving data.
The driving data is added progressively until a reset is performed. The data is retained even if the ignition key is removed.
- **“To destination”**
Driving data up to navigation destination.
If route guidance is active, the driving data is calculated and displayed up to the navigation destination.

Resetting driving data

The selected driving data display can be reset.

1. Main menu **“Trip”**.
2. Select the relevant driving data display and confirm.
3. Select **“Reset”** and confirm.

Tire Pressure Menu (Tire Pressure Monitoring System, TPMS)

This device complies with Part 15 of the FCC Rules and RSS-210 of Industry Canada.

Operation of this device is subject to the following two conditions:

1. This device may not cause harmful interference, and
2. This device must accept any interference received including interference that may cause undesired operation.

Changes or modifications not expressly approved by the party responsible for compliance could void the user's authority to operate the equipment. Each tire, including the spare (if provided), should be checked monthly when cold and inflated to the inflation pressure recommended by the vehicle manufacturer on the vehicle placard or tire inflation pressure label. (If your vehicle has tires of a different size than the size indicated on the vehicle placard or tire inflation pressure label, you should determine the proper tire inflation pressure for those tires).

For information on the tire inflation pressure label:
▷ Please see the chapter **“TIRES AND WHEELS”** on page 186.

As an added safety feature, your vehicle has been equipped with a Tire Pressure Monitoring System (TPMS) that illuminates a low tire pressure telltale (warning light) when one or more of your tires is significantly under-inflated.

Accordingly, when the low tire pressure telltale illuminates, you should stop, check your tires as soon as possible, and inflate them to the proper pressure. Driving on a significantly under-inflated tire causes the tire to overheat and can lead to tire failure. Under-inflation also reduces fuel efficiency

and tire tread life, and may affect the vehicle's handling and stopping ability.

The display as well as the settings for the Tire Pressure Monitoring System take place on the multi-function display.

However, the tire pressure must still be set manually on the wheel.

- ▷ Please see the chapter "TIRE PRESSURE FOR COLD TIRES (68 °F/ 20 °C)" on page 221.

WARNING

Maintaining tire pressure

Driving the vehicle with low tire pressure increases the risk of a tire failure and resulting loss of control. Furthermore, low tire pressure increases rate of wear of the affected tires.

Please note that the Tire Pressure Monitoring System is not a substitute for proper tire maintenance, and it is the driver's responsibility to maintain correct tire pressure, even if under-inflation has not reached the level to trigger illumination of Tire Pressure Monitoring System low tire pressure telltale. Low tire pressure reduces the road safety of the vehicle and destroys the tire and wheel.

Tire Pressure Monitoring System gives a warning about tire damage caused by a natural loss in pressure as well as about a gradual loss of pressure caused by foreign objects.

Tire Pressure Monitoring System cannot warn you about tire damage that occurs suddenly (e.g. flat tire due to abrupt external effects).

- ▷ When a red tire pressure warning appears, stop immediately in a suitable place and check the tires for damage. If necessary, remedy the damage with a tire sealant.
- ▷ Do not by any means continue to drive with defective tires.
- ▷ Sealing the tire with tire sealant is only an emergency repair so you can drive to the

nearest authorized Porsche dealer.

The maximum permitted speed is **50 mph (80 km/h)**.

3. Do not drive with tires in which the tire pressure drops again very quickly. In case of doubt, have tires checked by an authorized Porsche dealer.

- ▷ Defective tires must be replaced immediately at an authorized Porsche dealer.

Tires must never be repaired under any circumstances.

- ▷ If Tire Pressure Monitoring System is defective (e.g. defective wheel transmitter), contact an authorized Porsche dealer immediately and have the damage repaired.

The tire pressure will not be monitored at all or will be monitored only partially when Tire Pressure Monitoring System is defective.

For information on warning messages on the multi-function display:

- ▷ Please see the chapter "OVERVIEW OF WARNING AND INFORMATION MESSAGES" on page 109.
- ▷ Incomplete entries or selection of the wrong tires on the multi-function display affect the accuracy of warnings and messages. The settings in the tire pressure menu must be updated following a wheel change or changes in vehicle loading.
- ▷ Use only the pressure differences shown in the "**Fill info**" display in the **Tire pressure** menu or from the corresponding tire pressure warning when correcting the tire pressure.
- ▷ Tires can lose air over time without a tire defect being present. A tire pressure warning will then appear on the multi-function display. Check the tire pressure at the next opportunity.

Warning light

WARNING

Attention to TPMS malfunction indicator

Your vehicle has also been equipped with a TPMS malfunction indicator to indicate when the system is not operating properly.

The TPMS malfunction indicator is combined with the low tire pressure telltale.

When the system detects a malfunction, the telltale will flash for approximately one minute and then remain continuously illuminated. This sequence will continue upon subsequent vehicle start-ups as long as the malfunction exists.

When the malfunction indicator is illuminated, the system may not be able to detect or signal low tire pressure as intended.

TPMS malfunctions may occur for a variety of reasons, including the installation of replacement or alternate tires or wheels on the vehicle that prevent the TPMS from functioning properly.

- ▷ Always check the TPMS malfunction telltale after replacing one or more tires or wheels on your vehicle to ensure that the replacement or alternate tires and wheels allow the TPMS to continue to function properly.

The warning light in the instrument panel lights up:

- When a loss in pressure has been detected.
- In the event of a defect in Tire Pressure Monitoring System or a temporary fault.
- When learning new fitted wheels/wheel transmitters, as long as the vehicle's own wheels have not yet been recognized.

The tire pressure warning light on the instrument panel goes out only when the cause of the fault has been rectified.

Overview of Tire Pressure Monitoring System functions

Tire Pressure Monitoring System offers the following functions:

- Display of the actual tire pressure while the vehicle is in motion.
- **"Fill info"** display:
Display of the deviation from the required pressure (refilling pressure) at standstill.
- **"Tire type"** display:
Display of current settings (when the vehicle is stationary).
- Tire pressure warnings in two stages (yellow and red warning).

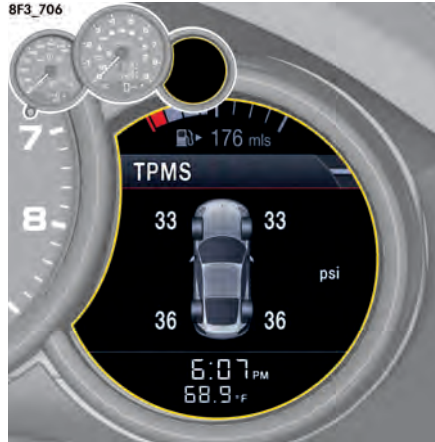

Tire pressure display on the multi-function display

Selecting the TPMS function on the multi-function display

1. Select main menu **"TPMS"**

The **"TPMS"** function displays the temperature-dependent tire pressures (actual pressures) in the four wheels.

You can watch the tire pressure rise as the temperature increases while driving.



Information

This display is only for information.

- ▷ Under no circumstances should the tire pressures be changed based on this display.

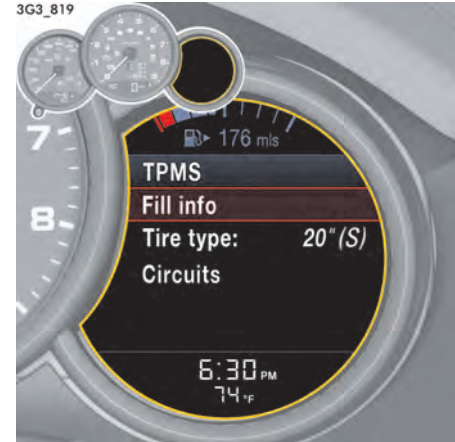

Viewing Fill info in the Tire pressure menu (only when vehicle is stationary)

You can read the tire pressures to be corrected in this display.

1. Main menu **"TPMS"**
2. Confirm **"TPMS"**.
3. Select the **"Fill info"** menu and confirm.

The tire pressure to be corrected (refill pressure) is indicated on the displayed wheel.

Example: If

“-1.5 psi (-0.1 bar/ -10 kPa)”

is displayed for the front right tire,

1.5 psi (0.1 bar/ 10 kPa)

must be added to this tire.

The displayed pressures take into account the tire temperature.

- ▷ Use only the pressure values shown in the “**Fill info**” display in the “**TPMS**” main menu or from the corresponding tire pressure warning when correcting the tire pressure.

Information

After the ignition is switched on, it can take up to approx. 1 minute until all tire pressures are displayed. Dashes (-) appear instead of the tire pressures.

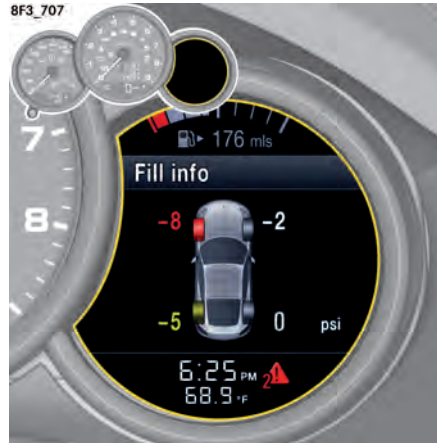

Viewing current settings in the TPMS menu

1. Main menu “TPMS”
2. Confirm “TPMS”.

Selecting tire type in the TPMS menu (type and size of fitted tire)

-  **WARNING** Exceeding maximum rated tire speed

Exceeding the maximum tire speed could result in a tire burst, causing loss of control of the vehicle.

- ▷ Always observe the permissible maximum speed of the respective tire.
- ▷ Porsche recommends obeying all traffic laws at all times to maintain the safety of yourself and all vehicle occupants.

-  **WARNING** Entering tire data and display

Incomplete entries or selection of the wrong tires on the multi-function display affect correct indication of warnings and messages.

- ▷ The settings must be updated in the “**TPMS**” menu after changing a wheel, filling with tire sealant or adding air (after previous warning “**Check tires**”).
- ▷ Please see the chapter “**RED WARNING – “Check tires”**” on page 93.

The new tire type and tire size must be selected even if the settings for the new set of wheels are the same as for the old wheels.

1. Main menu **"TPMS"**
2. Confirm **"TPMS"**.
3. Select **"Tire type"** and confirm.
4. Select
 "20" Summer" or
 "20" Winter"
and confirm.

- Option is selected.
- Option is not selected.

Tire selection has only been completed successfully when the following message appears on the multi-function display (example):

"No tire pressure monitoring System is learning".

- ▷ Please see the chapter "CHANGING A WHEEL AND REPLACING TIRES" on page 94.



Information

Before fitting tires with dimensions that are not already stored in the multi-function display, the missing information should be added to the multi-function display by your authorized Porsche dealer.

- ▷ Please contact your authorized Porsche dealer.
- ▷ Use only tires approved by Porsche.

The available items in the tire pressure menu depend on the model type. For this reason, some of the selection options shown here may not be available on your multi-function display.

System learning

Tire Pressure Monitoring System begins to "learn" the tires after a wheel change, wheel transmitter replacement or update of the tire settings. During this process, Tire Pressure Monitoring System recognizes the wheels and their locations.

The message **"No monitoring System is learning"** appears on the multi-function display.

The wheel learning process takes place exclusively when the vehicle is being driven (vehicle speed above 16 mph (25 km/h)).

Tire Pressure Monitoring System requires a certain amount of time to learn the wheels. During this time, the current tire pressures are not available on the multi-function display:

- The tire pressure warning light remains lit until all wheels have been learned.
- Lines (-.) appear on the display of the **"TPMS"** function.
- The required pressures for cold tires 68 °F (20 °C) are shown under **"Fill info"** in the **"TPMS"** main menu.

Position and pressure information is displayed as soon as Tire Pressure Monitoring System has assigned the wheels recognized as belonging to the vehicle to the correct wheel positions.

- ▷ Check the tire pressure for all wheels under **"Fill info"**.
- ▷ Correct the tire pressure to the required pressure if necessary (differential pressure value **"0.0"**).

Tire pressure warnings

The tire pressure warning light on the instrument panel and a corresponding message on the multi-function display warn about loss of pressure in two stages (yellow and red), depending on the amount of pressure loss.

3G3_819

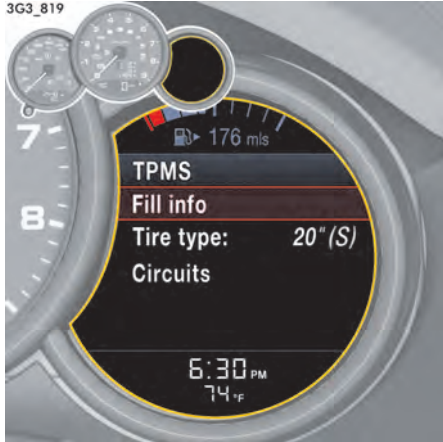

Selecting “Circuits” in the TPMS menu

For driving on a race circuit, you can set and monitor pressures different to those used for road mode.

Race circuit mode is **not** designed for driving on public roads.

This gives the experienced driver the option of customising tire pressure to suit race circuits, for optimum handling.

⚠ WARNING

Low Tire Pressure

The driver remains responsible when driving, e.g. setting tire pressures for driving on race circuits, regardless of Tire Pressure Monitoring System.

- ▷ Adjust the required pressure to suit the maximum intended driving speeds. Take into account the warning thresholds which trigger a tire pressure warning.

For information on warning thresholds and tire pressure warnings:

- ▷ Please see the chapter “TIRE PRESSURE WARNINGS” on page 93.

1. Main menu “TPMS”
2. Confirm “TPMS”.
3. Select “Circuits” and confirm.

The current actual tire pressures are displayed.

3G3_820

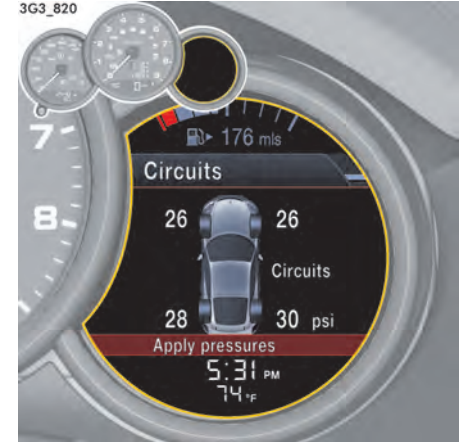

Setting tire pressure for race circuits



Information

The desired actual tire pressures must not be less than 26 psi (1.8 bar) at each wheel.

- ▷ Set the desired actual tire pressure for race circuits at the wheel. The actual tire pressures are updated in the “Circuits” display every 5 seconds for a maximum of 15 minutes

1. Main menu **"TPMS"**
 - > **"TPMS"**
 - > **"Circuits"**
2. Select **"Apply pressures"** and confirm.

 **Information**

If the tire pressure falls below minimum pressure, the message **"Note min. pressure 26 psi (1.8 bar)"** appears and the new pressures are not accepted. If this is the case, the required tire pressures must be set again.

The new tire pressures have only been accepted successfully when the message **"New target pressures"** appears on the multi-function display. When race circuit mode is activated,  is displayed permanently on the multi-function display.

Returning to road mode

There are **two** options for returning to road mode.

Option 1 without switching off the ignition

1. Main menu **"TPMS"**
 - > **"TPMS"**
 - > **"Circuits"**
2. Select **"No"** and confirm.

If you change from race circuit mode to road mode without first switching off the ignition, the previous tire selection continues to be monitored.

- ▷ Use the pressure differences shown in the **"Fill info"** display in the **"TPMS"** main menu or from the corresponding tire pressure warning when correcting the tire pressure.

Option 2 after switching off the ignition

When race circuit mode is activated, the **"Circuits"** screen appears on the multi-function display whenever the ignition is switched on, together with the prompt (selection): **"No"/"Yes"/"New pressure"**.

- **"No"**:
If you select **"No"** and then select the **"Tire type"** menu, the required tire pressures will be set back to road mode.

Tire Pressure Monitoring System will relearn the wheels once you have returned to road mode. During this process the required pressures for cold tires (20 °C) are shown under **"Fill info"** in the **"TPMS"** main menu.

- ▷ Please see the chapter **"SYSTEM LEARNING"** on page 90.
- ▷ Once the Tire Pressure Monitoring System has finished learning, check the tire pressure for all wheels under **"Fill info"**.
- ▷ Correct the tire pressure to the required pressure if necessary (differential pressure value **"0.0"**).
- **"Yes"**:
If you select **"Yes"**, this inserts the required tire pressures that you set for driving on a race circuit.
- **"New pressure"**:
If you select **"New pressure"**, you can set new required tire pressures for driving on a race circuit.

 **Information**

If you make no selection before driving off, the system automatically switches back to road mode and the message **"Tire change? Update settings"** appears.

- ▷ Update the multi-function display settings the next time the vehicle is stationary.

Tire pressure warnings

The tire pressure warning light on the instrument panel and a corresponding message on the multi-function display warn about loss of pressure in two stages (yellow and red), depending on the amount of pressure loss.

Information

Race circuit mode:

- If the actual tire pressure falls below 23 psi (1.6 bar) (e.g. due to cooling), a red warning is issued. The red warning stops as soon as actual tire pressure is above 23 psi (1.6 bar) (e.g. due to warming).
- If the pressure also falls below the warning threshold, the warning only stops when the tires are filled to the required pressure again (differential pressure value “0.0”) or a new required pressure is set in the “Circuits” menu.

For information on warning thresholds:

- ▷ Please see the chapter “RED WARNING – “Check tires”” on page 93. Always check for damage before filling the tires to the required pressure (differential pressure value “0.0”).



Yellow warning – “Top off air”

The pressure in the tire is too low by **more than 4 to 7 psi/0.3 to 0.5 bar/30 to 50 kPa**. The tire pressure warning specifies the affected tire and the target tire pressure.

- ▷ Fill up with air at the next opportunity.

This tire pressure warning appears:

- for approx. 10 seconds when the vehicle is stationary and the ignition is switched off or
- when the ignition is switched on again.

The warning can be acknowledged when the ignition is switched on.

The tire pressure warning light on the instrument panel goes out only when the tire pressure has been corrected (differential pressure value “0.0”).

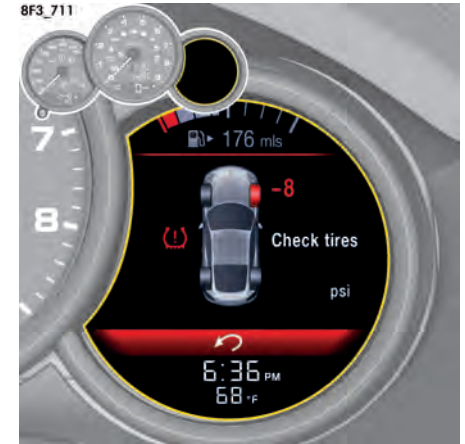

Red warning – “Check tires”

At speeds **below 100 mph (160 km/h)**:

- The pressure in the tire has dropped by **20 % below the required pressure** or **by more than 7 psi/0.5 bar/50 kPa**. This significant pressure loss is a danger to road safety.

At speeds **above 100 mph (160 km/h)**:

- The pressure in the tire has dropped by **more than 6 psi/0.4 bar/40 kPa**. This significant pressure loss is a danger to road safety.
- ▷ When the tire pressure warning appears, stop immediately at a suitable location. Check the indicated tire for signs of damage. If necessary, fill in tire sealant and set the correct tire pressure.

This tire pressure warning also appears when driving and can be acknowledged.

The tire pressure warning light on the instrument panel goes out only when the tire pressure has been corrected (differential pressure value “0.0”).



Speed warning - "Tire pressure Reduce speed"

At speeds **above 165 mph (270 km/h)**:

- The pressure in the tire has dropped by **more than 4 psi/0.3 bar/30 kPa**. This pressure loss is a danger to road safety.
- ▷ When the tire pressure warning appears, reduce speed to below 165 mph (270 km/h) until the warning disappears. When driving at very high speeds, increase the tire pressure to the required pressure (differential pressure value "**0.0**").

For information on tire sealing compound:

- ▷ Please see the chapter "FILLING IN SEALANT" on page 200.

⚠ Warning light

The warning light in the instrument panel lights up:

- When a loss in pressure has been detected.
- In the event of a defect in Tire Pressure Monitoring System or a temporary fault.
- When learning new fitted wheels/wheel transmitters, as long as the vehicle's own wheels have not yet been recognized.

A warning message also appears on the multi-function display in the instrument panel.

- ▷ Please see the chapter "OVERVIEW OF WARNING AND INFORMATION MESSAGES" on page 109.

The tire pressure warning light on the instrument panel goes out only when the cause of the fault has been rectified.

Changing a wheel and replacing tires

- ▷ New wheels must be fitted with radio transmitters for Tire Pressure Monitoring System. Before tires are changed, the battery charge condition of the wheel transmitters should be checked. We recommend that you get an authorized Porsche dealer to do this work as they have trained workshop personnel and the necessary parts and tools.
- ▷ Switch off the ignition when changing a wheel. The tire settings on the multi-function display must be updated after changing a wheel. If the tire settings are not updated, the message "**Tire change? Update settings**" is displayed on the multi-function display.
- ▷ Update the multi-function display settings the next time the vehicle is stationary.

Pressure increase as the result of temperature increase

In accordance with physical principles, the tire pressure changes as the temperature changes. For every 18 °F (10 °C) change in temperature, the tire pressure increases or decreases by approx. 1.5 psi (0.1 bar/10 kPa).

Partial monitoring

Monitoring of the other wheels is continued if there is a fault in one or two wheel transmitters.

- The tire pressure warning light lights up.
- The message **“Restricted monitoring”** appears on the multi-function display.
- No tire pressures are displayed on the multi-function display for wheels with faulty wheel transmitters.

No monitoring

In the event of faults, Tire Pressure Monitoring System cannot monitor the tire pressure.

The warning light on the instrument panel lights up and a corresponding message appears on the multi-function display.

Monitoring is not active:

- If Tire Pressure Monitoring System is faulty.
 - If wheel transmitters for Tire Pressure Monitoring System are missing.
 - During the learning phase after the tire settings have been updated.
 - After a wheel change without updating the tire settings.
 - If more than four wheel transmitters are recognized.
 - If there is external interference by other radio sources, e.g. wireless headphones.
 - If tire temperatures are too high.
- ▷ Please see the chapter **“OVERVIEW OF WARNING AND INFORMATION MESSAGES”** on page 109.

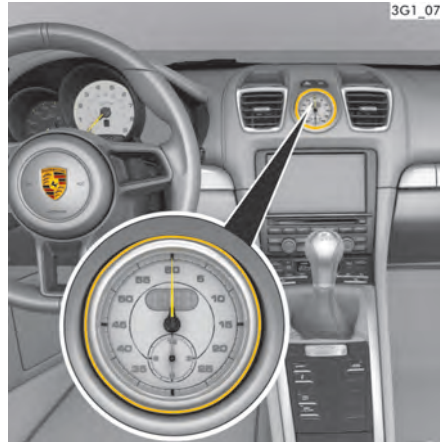

Chrono Menu (Stopwatch)

You can use the stopwatch to measure any times, e.g. on the race circuit or on work-related journeys. Measured lap times can be stored and evaluated if the vehicle is equipped with Porsche Communication Management (PCM).

- ▷ Please observe the chapter **“SPORT DISPLAY”** in the separate PCM operating instructions.

Driving data can be displayed, recorded and analysed on a smartphone using the Porsche Track Precision app (country-dependent).

- ▷ Please see the chapter **“PORSCHE TRACK PRECISION APP”** on page 129.

Automatic lap counting and timing are possible using the lap trigger available as an option via Porsche Tequipment.

- ▷ Please see the chapter **“LAP TRIGGER”** on page 130.

Stopwatch on the dashboard

The stopwatch has an analog and a digital display.

The large pointer of the analog display measures the seconds. The two small pointers measure hours and minutes. The display re-starts at zero after 12 hours.

Seconds and increments of 1/10th and 1/100th of a second can be read on the digital display.

The digital display and the multi-function display can show up to 99 hours and 59 minutes.

Stopwatch timing displays

The stopwatch time is displayed at different positions on the dashboard:

- In the stopwatch on the dashboard.
- In the **“Chrono”** menu in the multi-function display on the instrument panel.
- In the **“CAR”** main menu on the PCM.

Displaying the time on the stopwatch

You can configure the stopwatch on the dashboard to display the time in the multi-function display on the instrument panel.

For information on displaying the time on the stopwatch:

- ▷ Please see the chapter **“DISPLAYING TIME IN STOPWATCH ON DASHBOARD”** on page 107.

Chrono on multi-function display

All stopwatch displays are started and stopped in the **"Chrono"** menu on the multi-function display. For instructions on using the multi-function display:

- ▷ Please see the chapter "OPERATING THE MULTI-FUNCTION DISPLAY ON THE INSTRUMENT PANEL" on page 78.

1. Main menu: Select **"Chrono"** and confirm.



Information

If you exit the **"Chrono"** menu while the stopwatch is running, measurement will continue.

The stopwatch stops after the ignition is switched off. If the ignition is switched on again within approx. 4 minutes, the stopwatch will continue to run.

The only way to reset the stopwatch to zero is by selecting **"Reset"** in the **"Chrono"** menu.

For information on resetting the stopwatch:

- ▷ Please see the chapter "RESETTING THE STOPWATCH TIME" on page 97.



- A - Number of completed laps
- B - Current stopwatch time
- C - Reference time (fastest lap)
- D - Circle display: Comparison of current lap time with the reference time

Starting timing

1. Main menu **"Chrono"**
2. Select **"Start"** and confirm.

The stopwatch time **B** is displayed simultaneously on all stopwatch displays in the vehicle.

Stopping lap/Starting new lap

The current stopwatch time can be stored as a lap time while the stopwatch is still running.

1. Main menu **"Chrono"**
2. Select **"Round"** and confirm.

The lap counter value **A** is incremented by the value of 1.

The time of the fastest completed lap is stored temporarily as a reference value **C**.

The stopwatch time **B** and the circle display **D** turn a different color to indicate whether the current lap time is quicker than, slower than or identical to the current fastest lap.

- Green: Current lap time is faster.
- Yellow: Current lap time is identical.
- Red: Current lap time is slower.



Information

If a reference time has not been stored yet, the reference time position **C** remains blank.

The segment display is not colored.

A maximum of 63 laps can be stored during each session.

The current stopwatch time **B** and the display **D** are only highlighted in colour when driving.

Storing intermediate time

You can store an intermediate time while the stopwatch is still running.

1. Main menu **“Chrono”**
2. Select **“Interim”** and confirm.

The intermediate time is displayed temporarily on the multi-function display. It is not stored. Timing continues in the background.

Stopping timing

You can stop the stopwatch at any time.

1. Main menu **“Chrono”**
2. Select **“Stop”** and confirm.

The stopwatch time **B** stops.

Continuing timing

You can resume timing again after stopping the stopwatch.

1. Main menu **“Chrono”**
> **“Stop”**
2. Select **“Cont.”** and confirm.

The stopwatch time **B** continues.

Resetting the stopwatch time

The stopwatch time can be reset to zero.

1. Main menu **“Chrono”**
> **“Stop”**
2. Select **“Reset”** and confirm.

All stopwatch time displays are reset to zero.



Gear Shift Assist Menu

(in vehicles with manual transmission)

In order to provide assistance during performance-oriented driving, a graphic display of the upshift indicator is shown in the **“Gear shift assist”** main menu.

The gearshift assistant displays a prompt to shift to the next-higher gear with a pre-indication via segments that fill up. The sequence in which the segments are filled with color is **white, yellow, red**.

8F3_814



When all the segments are filled in red, a “+” sign appears next to the engaged gear in the display as a prompt to shift to the next-higher gear.

8F3_817

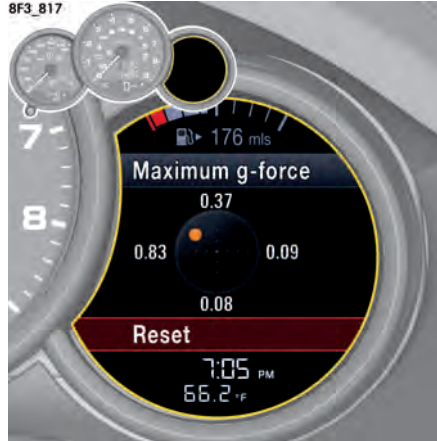

G-Forces Menu

In the “G-forces” main menu, the current lateral and longitudinal acceleration forces are shown graphically (in m/s^2) in the form of a circular diagram.

The maximum occurring longitudinal and lateral acceleration forces are displayed (in m/s^2) in the “Maximum g-force” sub-menu.

The values can be reset via the menu item “Reset” (illustration).

1. “G-forces” main menu
2. Confirm “Maximum g-force”.
3. Select “Reset” and confirm.

3G3_827



Performance Menu

In the “Performance” main menu, the current power or torque can be displayed graphically as a function of engine speed.

Power

1. Main menu “Performance”
2. Select “Performance” and confirm.

Torque

1. Main menu “Performance”
2. Select “Torque” and confirm.

Vehicle Settings on the Multi-Function Display

Different settings can be adjusted in the multi-function display on the instrument panel depending on the vehicle equipment.

Selecting settings menu

1. Main menu: Select **“Vehicle”**
> **“Settings”**
and confirm

Selecting setting options or activating vehicle functions

A symbol positioned in front of a setting option indicates whether the option is selected or a vehicle function is activated.

Selecting one of several options

- Option is selected.
- Option is not selected.

Activating and deactivating functions

- Function is activated.
- Function is deactivated.

Resetting to factory settings

All settings made in the multi-function display can be reset to the factory settings:

Information

All personal settings that have already been stored will be lost as a result of resetting to factory settings.

1. Main menu **“Vehicle”**
> **“Settings”**
2. Select **“Fact. settings”**
and confirm.
3. Select **“Yes”**
and confirm.

Adapting appearance of multi-function display

The contents and appearance of the multi-function display can be adapted individually.

1. Main menu: Select **“Vehicle”**
> **“Settings”**
> **“Display”**
and confirm.

Selecting main menu display contents

Individual elements in the main menu can be hidden and shown as required.

The main menu items **“Audio”**, **“Phone”**, **“Map”**, **“Navigation”**, **“Trip”**, **“TPMS”**, **“Chrono”**, **“Gearshift assist”** and **“G-Force”** can be hidden or shown.

The menu items **“Vehicle”** cannot be hidden.

1. Main menu **“Vehicle”**
> **“Settings”**
> **“Display”**
2. Select **“Menu scope”**
and confirm.

3. Select the desired main menu item.
4. Confirm your selection.

- Menu item is displayed.
- Menu item is hidden.

Adapting display contents of audio main menu

In the audio main menu, you can display either a list of all radio stations currently within range or a list of all stored radio stations.

1. Main menu **“Vehicle”**
> **“Settings”**
> **“Display”**
2. Select **“Audio”**
and confirm.
3. Select the desired display contents
and confirm.

Available display contents:

- **“Station list”**
List of stations currently within range.
- **“Preset list”**
List of stored stations.

Adapting display contents in vehicle information area

You can select four of the many items of vehicle information for display in the **“Vehicle”** menu and assignment to the display areas **1**, **2**, **3** and **4**.

1. Main menu **“Vehicle”**
> **“Settings”**
> **“Display”**
2. Select **“Vehicle menu”**
and confirm.

3. Select

“Field 1:” or
“Field 2:” or
“Field 3:” or
“Field 4:”
and confirm.

4. Select the desired display contents and confirm.

Available display contents:

- “Veh. voltage”
- “Oil pressure”
- “Oil temperature”
- “Coolant temp.” – Coolant temperature
- “Fuel Range”
- “Dst: Arrival” – Arrival time at destination
- “Int: Arrival” – Arrival time at intermediate destination
- “Dst: Trip time” – Driving time to destination
- “Int: Trip time” – Driving time to intermediate destination
- “Compass”
- “GPS height”
- “Time”
- “Date”
- “Station/Track” – Current radio station/
music track
- “Phone info” – Network strength/network
name
- “Blank line” – Line remains empty



Information

One item of vehicle information cannot be assigned to several display areas.

8F3_816

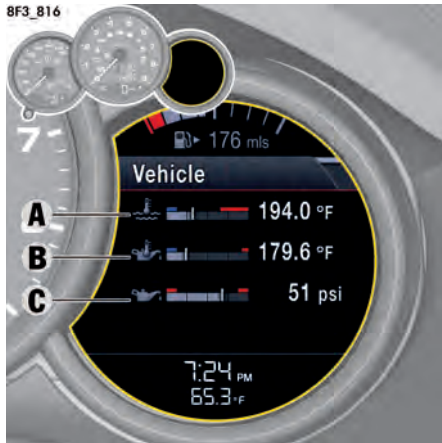

Example configuration of multi-function display information area

- A** - Coolant temperature gauge
- B** - Engine oil temperature gauge
- C** - Engine oil pressure gauge

A – Coolant temperature gauge

If the cooling system is in any way faulty, consult an authorized Porsche dealer.

Bar in left area – engine cold

- ▷ Avoid high engine speeds and heavy engine loading.

Bar in center area – normal operating temperature

The bar may move up to the red area when the engine is under heavy load and the outside temperature is high.

Coolant temperature warning

If the coolant temperature is too high, the temperature gauge moves to the maximum mark and the warning message “**Engine too hot Park vehicle to cool down**” appears on the multi-function display in the instrument panel.

- ▷ Switch the engine off and let it cool.
- ▷ Check radiators and air guides in front end of vehicle for obstructions.
- ▷ Check the coolant level.
 - Top up with coolant if necessary.
- ▷ Have the fault corrected.
- ▷ Please see the chapter “CHECKING THE COOLANT LEVEL AND ADDING COOLANT” on page 184.
- ▷ Please see the chapter “OVERVIEW OF WARNING AND INFORMATION MESSAGES” on page 109.



Information

To prevent excessive temperatures, the cooling air ducts must not be obstructed by covering them (e.g. with film, “stone guards”, etc.).

Coolant level warning

At engine temperatures **below 140 °F (60 °C)**:

A low coolant level is indicated by the warning message “**Refill coolant Observe engine temperature**” on the multi-function display in the instrument panel.

- ▷ Add coolant.

At engine temperatures **above 140 °F (60 °C)**:

A low coolant level is indicated by the warning message “**Refill coolant immediately Do not drive on**” on the multi-function display in the instrument panel. The temperature gauge moves to the maximum mark.

- ▷ Switch engine off and let it cool.

- ▷ Add coolant.

If the coolant level is low, warning indicators may light up if the vehicle tilts at an extreme angle (e.g. steep slopes) or generates high lateral acceleration while travelling round long bends (e.g. driving in circles). If the warnings do not disappear once the vehicle has assumed “normal” operating state, check the coolant level.

- ▷ Please see the chapter “CHECKING THE COOLANT LEVEL AND ADDING COOLANT” on page 184.
- ▷ Please see the chapter “OVERVIEW OF WARNING AND INFORMATION MESSAGES” on page 109.

NOTICE

Risk of engine damage.

- ▷ Do not continue driving if the warning persists even when the engine coolant level is correct.
- ▷ Have the fault corrected.

We recommend that you get an authorized Porsche dealer to do this work as they have trained workshop personnel and the necessary parts and tools.

B – Engine oil temperature gauge

A warning message will appear on the multi-function display in the instrument panel if the engine oil temperature is too high.

- ▷ Reduce engine speed and engine load immediately if the red zone is reached.

For information on warning messages on the multi-function display:

Please see the chapter “OVERVIEW OF WARNING AND INFORMATION MESSAGES” on page 109.

C – Engine oil pressure gauge

The oil pressure is controlled as required and should be at least 51 psi (3.5 bar) at an engine speed of 5,000 rpm.

The engine oil pressure varies depending on the engine speed, oil temperature and engine load.

If oil pressure drops abruptly and a message is displayed on the multi-function display when the engine is running or while driving:

- ▷ Stop immediately in a suitable place.
- ▷ Switch off the engine.
- ▷ Check whether there is an obvious oil leak on or under the car.
- ▷ Select “**Oil level**” on the multi-function display.
- ▷ Please see the chapter “DISPLAY AND MEASUREMENT OF THE ENGINE OIL LEVEL” on page 82.
- ▷ Add engine oil if necessary.

NOTICE

Risk of engine damage.

- ▷ Do not continue driving if there is an obvious oil leak.
- ▷ Do not continue driving if the warning message appears even when the oil level is correct.
- ▷ Have the fault corrected.

We recommend that you get an authorized Porsche dealer to do this work as they have trained workshop personnel and the necessary parts and tools.

Displaying PCM information on the multi-function display

You can configure the multi-function display to temporarily display different items of information relating to Porsche Communication Management (PCM).

1. Main menu “**Vehicle**”
 - > “**Settings**”
 - > “**Display**”
2. Select “**PCM display**” and confirm.
3. Select desired PCM information.
4. Confirm your selection.
 - Information is displayed.
 - Information is not displayed.

Available PCM information:

- “**Map info**”
Navigation map appears automatically when navigation information is available.
- “**Phone info**”
Information on incoming and outgoing calls is displayed.
- “**Voice control**”
Help text appears when the voice control button is pressed.
- “**Arrow info**”
Navigation arrow appears automatically when navigation information is available.

Adapting fuel gauge

The fuel range can be shown or hidden on the fuel gauge (upper line).

1. Main menu **"Vehicle"**
 - > **"Settings"**
 - > **"Display"**
2. Select **"Upper line"** and confirm.
3. Select display contents and confirm.

Available display content:

- **"Fuel Range"**

Adapting status area

You can assign the current time and/or outside temperature to the status area in the multi-function display.

1. Main menu **"Vehicle"**
 - > **"Settings"**
 - > **"Display"**
2. Select **"Lower line"** and confirm.
3. Select the desired display contents and confirm.

Available display contents:

- **"Time"**
- **"Temperature"**
- **"Time & Temp."**

Adjusting display brightness

The brightness of the multi-function display can be adjusted to suit individual requirements.

1. Main menu **"Vehicle"**
 - > **"Settings"**
 - > **"Display"**
2. Select **"Brightness"** and confirm.
3. Select the desired brightness and confirm.

Light and visibility settings

The exterior lights, interior lighting and visual aids for reversing the vehicle can be adapted individually.

1. Main menu: Select **"Vehicle"**
 - > **"Settings"**
 - > **"Light & Visibility"**and confirm.

Adjusting exterior lights

You can adapt the exterior light functions on the vehicle e.g. the dynamic high beam and off delays of the Welcome Home and Entry functions in the **"Exterior lights"** menu.

1. Main menu: Select **"Vehicle"**
 - > **"Settings"**
 - > **"Light & Visibility"**
 - > **"Exterior lights"**and confirm.

Adjusting off delay for Welcome Home and Entry functions

The off delay of the Welcome Home and Entry functions can be adapted individually.

1. Main menu **"Vehicle"**
 - > **"Settings"**
 - > **"Light & Visibility"**
 - > **"Exterior lights"**
2. Select **"Fade-out"** and confirm.
3. Select the desired off delay and confirm.

Adjusting interior lights

Interior light functions on the vehicle can be adapted individually in the **"Interior lights"** menu.

1. Main menu: Select **"Vehicle"**
 - > **"Settings"**
 - > **"Light & Visibility"**
 - > **"Interior lights"** and confirm.

Activating or deactivating interior lights when the door is opened (depending on equipment)

You can configure the interior lights to be switched on when the door is opened.

1. Main menu **"Vehicle"**
 - > **"Settings"**
 - > **"Light & Visibility"**
 - > **"Interior lights"**

2. Select **"by opening door"**

3. Confirm your selection.



Interior lights are activated.



Interior lights are deactivated.

Adjusting brightness of orientation lighting

The brightness of the orientation lighting can be adapted individually.

1. Main menu **"Vehicle"**
 - > **"Settings"**
 - > **"Light & Visibility"**
 - > **"Interior lights"**

2. Select **"Orientation"** and confirm.

3. Select the desired brightness and confirm.

Ambient lighting

The brightness of the ambient lighting can be adapted individually.

1. Main menu **"Vehicle"**
 - > **"Settings"**
 - > **"Light & Visibility"**
 - > **"Interior lights"**

2. Select **"Ambient light"** and confirm.

3. Select the desired brightness and confirm.

Setting interior lighting off delay

The off delay for the lighting in the passenger compartment after closing the vehicle doors can be adapted individually.

1. Main menu **"Vehicle"**
 - > **"Settings"**
 - > **"Light & Visibility"**
 - > **"Interior lights"**

2. Select **"Fade-out"** and confirm.

3. Select the desired off delay and confirm.

Activating and deactivating rain sensor operation

You can configure the windshield wiper to adjust the wiper speed automatically when it is raining.

1. Main menu **"Vehicle"**
 - > **"Settings"**
 - > **"Light & Visibility"**
 - > **"Wiper"**

2. Select **"Rain sensor"** and confirm.

3. Select the desired setting and confirm.

Available setting options:

- **"Automatic"**
The wiper speed is automatically adjusted.
- **"Manual"**
The wiper speed must be manually adjusted using the wiper switch.

Locking settings

The locking and unlocking settings on the vehicle can be adjusted.

The Easy Entry function can be switched on and off.

1. Main menu: Select **“Vehicle”**
> **“Settings”**
> **“Locking”**
and confirm.

Setting door unlocking

You can configure specific doors to unlock when the vehicle is unlocked.

1. Main menu **“Vehicle”**
> **“Settings”**
> **“Locking”**
2. Select **“Door unlock”**
and confirm.
3. Select the desired setting
and confirm.

Available setting options:

- **“All doors”**
All doors are unlocked when the vehicle is unlocked.
- **“Driver’s door”**
The driver’s door is unlocked when the vehicle is unlocked.

Setting door locking

You can configure the doors to remain unlocked or lock automatically after a delay on entering the vehicle.

1. Main menu **“Vehicle”**
> **“Settings”**
> **“Locking”**
2. Select **“Door lock”**
and confirm.
3. Select the desired setting
and confirm.

Available setting options:

- **“Off”**
The doors are not locked automatically after entering the vehicle.
- **“After ign. on”**
The doors are locked automatically when the ignition is switched on.
- **“After drive-off”**
The doors are locked automatically after driving off.

Switching Comfort Entry on and off

You can configure the driver’s seat and steering wheel to move back automatically and allow the driver to get in and out of the vehicle more easily.

1. Main menu **“Vehicle”**
> **“Settings”**
> **“Locking”**
2. Select **“Comfort Entry”**.
3. Confirm your selection.
 Comfort Entry is activated.
 Comfort Entry is deactivated.

Setting air conditioning

(on vehicles with 2-zone air conditioning)

The automatic air conditioning can be changed individually.

1. Main menu: Select **“Vehicle”**
> **“Settings”**
> **“Air conditioning”**
and confirm.

Adjusting air flow

The strength of the air flow and the air quantity can be adjusted.

1. Main menu **“Vehicle”**
> **“Settings”**
> **“Air conditioning”**
2. Select **“Air flow”**
and confirm.
3. Select the desired setting
and confirm.

Available setting options:

- **“Soft”**
- **“Normal”**
- **“Strong”**

Switching extended ventilation panel on and off

The extended ventilation panel on top of the dashboard can be switched on or off.

1. Main menu **"Vehicle"**
 - > **"Settings"**
 - > **"Air conditioning"**
2. Select **"Vent. panel"**.
3. Confirm your selection.
 - Ventilation panel is activated.
 - Ventilation panel is deactivated.

Switching automatic air-recirculation mode on/off

You can configure the fresh air supply to adjust automatically to the air quality.

1. Main menu **"Vehicle"**
 - > **"Settings"**
 - > **"Air conditioning"**
2. Select **"Auto air circ."**.
3. Confirm your selection.
 - Automatic air-recirculation mode is activated
 - Automatic air-recirculation mode is deactivated

Setting date and time

The date and time displays on the vehicle can be adjusted individually.

Information

On vehicles with Porsche Communication Management (PCM), the date and time are set and synchronised automatically by satellite navigation signals (GPS).

Some setting options may be temporarily unavailable, depending on satellite signal reception.

1. Main menu: Select **"Vehicle"**
 - > **"Settings"**
 - > **"Date & Time"**and confirm.

Setting the time

The time, time format and time zone can be set in the **"Time"** menu.

1. Main menu: Select **"Vehicle"**
 - > **"Settings"**
 - > **"Date & Time"**
 - > **"Time"**and confirm.

Displaying GPS time

The time can be synchronised via the GPS signal and displayed.

1. Main menu **"Vehicle"**
 - > **"Settings"**
 - > **"Date & Time"**
 - > **"Time"**
2. Select **"GPS time"**
3. Confirm your selection.
 - Time synchronised with GPS.
 - Time not synchronised with GPS.

Setting the time format

The time can be displayed in 12-hour or 24-hour format.

1. Main menu **"Vehicle"**
 - > **"Settings"**
 - > **"Date & Time"**
 - > **"Time"**
2. Select **"Format"** and confirm.
3. Select the desired setting and confirm.

Available setting options:

- **"12h"**
- **"24h"**

Setting current time

On vehicles without Porsche Communication Management (PCM), the hours and minutes can be set separately when setting the time.

1. Main menu **"Vehicle"**
> **"Settings"**
> **"Date & Time"**
> **"Time"**

2. Select **"Hour/Minute"**

3. Set the desired time and confirm.

Setting time zone

The time zone of the vehicle clock can be set individually on vehicles with Porsche Communication Management (PCM).

1. Main menu **"Vehicle"**
> **"Settings"**
> **"Date & Time"**
> **"Time"**

2. Select **"Zone"** and confirm.

3. Select the desired time zone and confirm.

Setting the date

The date and date format can be changed in the **"Date"** menu.

1. Main menu: Select **"Vehicle"**
> **"Settings"**
> **"Date & Time"**
> **"Date"**
and confirm.

Setting the date format

The date format can be adjusted.

1. Main menu **"Vehicle"**
> **"Settings"**
> **"Date & Time"**
> **"Date"**

2. Select **"Format"** and confirm.

3. Select the desired setting and confirm.

Available setting options:

- **"DD.MM.YYYY"**
- **"MM/DD/YYYY"**
- **"YYYY/MM/DD"**

Setting the current date

The day, month and year can be set individually on vehicles without the navigation module.

1. Main menu: Select **"Vehicle"**
> **"Settings"**
> **"Date & Time"**
> **"Date"**
and confirm.

2. Select **"Date"**.

3. Set the desired date and confirm.

Setting Daylight Saving Time

The vehicle clock can be configured to change to Daylight Saving Time (DST).

1. Main menu **"Vehicle"**
> **"Settings"**
> **"Date & Time"**

2. Select **"DST (+01:00)"**

3. Confirm your selection.

- Daylight Saving Time is activated.
- Daylight Saving Time is deactivated.

Displaying time in stopwatch on dashboard

You can configure the stopwatch on the dashboard to display the time.

1. Main menu **"Vehicle"**
 - > **"Settings"**
 - > **"Date & Time"**
2. Select **"Time – Chrono"**
3. Confirm your selection.
 - Time is displayed.
 - Time is not displayed.

Setting units

You can select the units of measurement for vehicle displays such as the speed on the digital speedometer in the instrument panel, the temperature gauge in the air-conditioning displays and the tire pressure display on the multi-function display.

1. Main menu: Select **"Vehicle"**
 - > **"Settings"**
 - > **"Units"**and confirm.

Setting speedometer units

The units of the speed and distance information on the speedometer can be adjusted.

1. Main menu **"Vehicle"**
 - > **"Settings"**
 - > **"Units"**
2. Select **"Speedometer"**.
3. Select the desired setting and confirm.

Available setting options:

- **"km / km/h"**
- **"Miles / mph"**

Setting unit for temperature gauges

The measurement unit for temperature gauges can be changed.

1. Main menu **"Vehicle"**
 - > **"Settings"**
 - > **"Units"**
2. Select **"Temperature"**
3. Select the desired setting and confirm.

Available setting options:

- **"°C"**
- **"°F"**

Setting unit for Tire Pressure Monitoring System display

The measurement unit for the Tire Pressure Monitoring System display can be changed.

1. Main menu **"Vehicle"**
 - > **"Settings"**
 - > **"Units"**
2. Select **"TPMS"**.
3. Select the desired setting and confirm.

Available setting options:

- **"bar"**
- **"psi"**

Setting unit for fuel consumption display

The unit can be set for the fuel consumption display.

1. Main menu **"Vehicle"**
 - > **"Settings"**
 - > **"Units"**
2. Select **"Consumpt"**.
3. Select the desired setting and confirm.

Available setting options:

- **"l/100km"**
- **"MPG (US)"**
- **"MPG (UK)"**
- **"km/l"**

Changing the language

The language of the display text on the multi-function display can be changed.

1. Main menu **“Vehicle”**
> **“Settings”**
> **“Language”**
2. Select the desired language and confirm.

Adjusting volume of warning and information tones

The volume of the warning tones and ParkAssist information tones can be adjusted.

Adjusting ParkAssist volume

The volume of the ParkAssist information tones can be adjusted.

1. Main menu **“Vehicle”**
> **“Settings”**
> **“Volume”**
2. Select **“ParkAssist”**.
3. Select the desired setting and confirm.

Available setting options:

- **“Loud”**
- **“Medium”**
- **“Low”**

Adjusting volume of warning tones

The volume of the warning tones can be adjusted individually.

1. Main menu **“Vehicle”**
> **“Settings”**
> **“Volume”**
2. Select **“Warn. tones”**.
3. Select the desired setting and confirm.

Available setting options:

- **“Loud”**
- **“Medium”**
- **“Low”**

Overview of Warning and Information Messages

If a warning message appears, always refer to the corresponding sections in this Owner's Manual.

Warning messages are issued only if all measurement prerequisites are met.

Therefore, check all fluid levels regularly – in particular, always check the engine oil level before refuelling.

Warning and information message categories

Red System failure or warning







- ▷ Visit or consult an authorized Porsche dealer immediately.











Yellow fault or system failure warning



















- ▷ Visit an authorized Porsche dealer at the next opportunity.

















White Information/message



















- ▷ Visit an authorized Porsche dealer at the next opportunity or remedy yourself.

















Light in instrument panel	Warning and information message in the multi-function display	Meaning/Action required
	Oil press. too low Park vehicle safely	Stop immediately in a suitable place and switch engine off. Do not continue driving. Select "Oil measurement" on the multi-function display. Add engine oil if necessary. Do not continue driving if the warning message is displayed despite the oil level being correct. Have the fault corrected at an authorized Porsche dealer.
	Oil pressure measurement fault Driving permitted Consult a workshop	Adapt your driving style and speed to the changed conditions. Have the fault corrected at an authorized Porsche dealer.
	Oil temperature too high Reduce load	Switch engine off and let it cool. Check oil level and, if necessary, add oil.
	Oil temperature indicator fault Consult a workshop Driving permitted	Adapt your driving style and speed to the changed conditions. Have the fault corrected at an authorized Porsche dealer.
	Oil level measurement fault Consult a workshop Driving permitted	Adapt your driving style and speed to the changed conditions. Have the fault corrected at an authorized Porsche dealer.
	No inform. / oil level available now	The oil level can be checked after waiting for approx. 1 minute with the vehicle parked on a level surface and the engine at operating temperature. If the rear luggage compartment lid is opened when the engine is cold (e.g. to top up engine oil), the oil level cannot be displayed for a certain time.





















Light in instrument panel	Warning and information message in the multi-function display	Meaning/Action required
	 <p>Oil level minimum reached Refill oil</p>	Top up engine oil immediately.
	 <p>Oil level below min. Refill oil at once Do not drive on</p>	Top up engine oil immediately.
	 <p>Oil level above maximum Consult a workshop Driving permitted</p>	Adapt your driving style and speed to the changed conditions. Visit an authorized Porsche dealer at the next opportunity and have the oil drained to the correct level.
Gauge moves to maximum mark	 <p>Engine too hot Park vehicle to cool down</p>	Coolant or engine oil temperature is too high. Switch off engine and let it cool. Check coolant or engine oil level. If necessary, top up coolant / engine oil.
	 <p>Refill coolant Observe engine temperature</p>	Check coolant level. Add coolant if necessary.
Gauge moves to maximum mark	 <p>Refill coolant immediately Do not drive on</p>	Switch engine off and let it cool. Check coolant level. Add coolant if necessary.
	 <p>Cooling system fault Consult a workshop Service required</p>	Have the fault corrected at an authorized Porsche dealer.
	 <p>Coolant temp indicator fault Driving permitted Consult a workshop</p>	Adapt your driving style and speed to the changed conditions. Have the fault corrected at an authorized Porsche dealer.
	 <p>Engine fan failure Avoid full load Driving permitted</p>	Adapt your driving style and speed to the changed conditions. Have the fault corrected at an authorized Porsche dealer.
	 <p>Generator fault Park vehicle safely</p>	Stop in a suitable place and switch engine off. Do not continue driving. Have the fault corrected at an authorized Porsche dealer.
	 <p>Low battery Start the engine and run for extended period</p>	Start the engine immediately so that the battery can be charged.







Light in instrument panel	Warning and information message in the multi-function display	Meaning/Action required
	 Low battery Consumption off	The power supply to various comfort features is deactivated to prevent the battery from discharging.
	 Battery protection was active during parking	The power supply to various features was deactivated during parking to prevent the battery from discharging.
	 Battery function restricted Consult a workshop	Consult an authorized Porsche dealer.
	 Reduced power Driving permitted Consult a workshop	Adapt your driving style and speed to the changed conditions. Consult an authorized Porsche dealer.
	 Engine control fault Consult a workshop Driving permitted	Adapt your driving style and speed to the changed conditions. Have the fault corrected at an authorized Porsche dealer.
	 Please start engine manually	Start engine manually at the ignition.
	 Please switch off the ignition	To prevent the battery from discharging, switch off the ignition when leaving the vehicle after the engine was stopped automatically.
	 Press clutch	Manual transmission: Depress clutch pedal when starting.
BRAKE 	 Brake fluid level Park vehicle safely	Stop immediately in a suitable place. Do not continue driving. Have the fault corrected at an authorized Porsche dealer.
BRAKE 	 Brake distribution fault Park vehicle safely	Stop immediately in a suitable place. Do not continue driving. Have the fault corrected at an authorized Porsche dealer.
BRAKE 	 Brake cooling faulty	Brake temperature too high. Stop the vehicle at a suitable place, switch off engine and allow the brake to cool down. Have the fault corrected at an authorized Porsche dealer.
ABS 	 ABS/PSM failure Adapted driving permitted	Adapt your driving style and speed to the changed conditions. Have the fault corrected at an authorized Porsche dealer.

Light in instrument panel	Warning and information message in the multi-function display	Meaning/Action required
	 <p>Wear limit Change brake pads Driving permitted</p>	<p>Have brake pads replaced immediately. Adapt your driving style and speed to the changed conditions. Consult an authorized Porsche dealer.</p>
<p>BRAKE</p>  <p>flashes</p>	 <p>Release parking brake</p>	<p>Pull the electric parking brake switch.</p>
<p>BRAKE</p> 	<p>Press brake pedal</p>	<p>Press the brake pedal before releasing the electric parking brake.</p>
	 <p>Fault parking brake</p>	<p>Have the fault corrected at an authorized Porsche dealer.</p>
	 <p>Electric parking brake in service mode</p>	<p>Have the fault corrected at an authorized Porsche dealer.</p>
<p>BRAKE</p>  <p>flashes</p>	 <p>Emergency braking</p>	<p>Emergency braking function of the electric parking brake active.</p>
<p>BRAKE ABS</p>   	 <p>PSM system error Park vehicle safely</p>	<p>Stop the vehicle in a suitable place. Do not continue driving. Have the fault corrected immediately at an authorized Porsche dealer.</p>
	 <p>ESC + TC failure Adapted driving permitted</p>	<p>Adapt your driving style and speed to the changed conditions. Have the fault corrected at an authorized Porsche dealer.</p>
	 <p>ESC switched off</p>	<p>Electronic Stability Control (ESC) switched off.</p>

Light in instrument panel	Warning and information message in the multi-function display	Meaning/Action required
	 ESC switched on	Electronic Stability Control (ESC) switched on.
 and TC OFF	 ESC + TC switched off	Electronic Stability Control (ESC) and Traction Control (TC) switched off.
	 ESC + TC switched on	Electronic Stability Control (ESC) and Traction Control (TC) switched on.
ABS 	 Roll mode active	Roll mode is switched on.
Fuel gauge warning light on	 Mind remaining distance	Refuel at the next opportunity.
	 Fault tank display service necessary	Have the fault corrected at an authorized Porsche dealer.
	 Check tank cap	Position tank cap correctly and screw on until it locks securely.
	 Refill washer fluid	
	 Fasten seat belt	All vehicle occupants must fasten their safety belts.
	 Loss of airbag Pilot lamp Service required	Have the fault corrected at an authorized Porsche dealer.
	 Passenger airbag on/off	The passenger airbag is switched on/off.
	 Power steering fail. Increased effort Driving permitted	Adapt your driving style and speed to the changed conditions. Have the fault corrected at an authorized Porsche dealer.
	 Power steering restricted Consult a workshop Driving permitted	Steering assistance is temporarily reduced. Adapt your driving style and speed to the changed conditions. Consult an authorized Porsche dealer.
	 Remove key from ignition	

Light in instrument panel	Warning and information message in the multi-function display	Meaning/Action required
	 Remove key from trunk	
	 Key not found / Key malfunction Change key position	Make sure that you have the driver's key with you.
	 Replace ignition key battery	Replace the battery in the driver's key.
	 Multiple keys recognized in vehicle	Information message: Several driver's keys in the vehicle, e.g. in the possession of a passenger.
	 PADM deactivated Service required Driving permitted	Have the fault corrected at an authorized Porsche dealer.
	 Chassis system fault Adapted driving permitted	Vehicle handling may be affected. Adapt your driving style and speed to the changed conditions. Have the fault corrected at an authorized Porsche dealer.
	 Chassis system failure	Stop immediately in a suitable place. Do not drive off or continue driving. Have the fault corrected at an authorized Porsche dealer.
	 Check tires	Tire Pressure Monitoring System detects a pressure loss of more than 20% below the required pressure or more than 7 psi (0.5 bar) at a speed of less than 100 mph (160 km/h), more than 6 psi (0.4 bar) at a speed greater than 100 mph (160 km/h) and more than 4 psi (0.3 bar) at a speed greater than 165 mph (270 km/h). Stop in a suitable place and check the tires indicated for damage. If necessary, fill in tire sealant and set the correct tire pressure.
	 Note min. pressure 26 psi (1.8 bar)	Tires have fallen below the minimum required pressure. For driving on race circuits, adjust tire pressures to at least 26 psi/1.8 bar/180 kPa at each wheel.
	 Top off air	Tire Pressure Monitoring System detects a pressure loss of more than 4 psi (0.3 bar). Correct the tire pressure at the next opportunity.
	 Restricted monitoring	Fault on one or both wheel transmitters. Have the fault corrected at an authorized Porsche dealer.
	 No tire pressure monitoring System is learning	Tire Pressure Monitoring System requires a certain amount of time to learn the wheels. During this time, the current tire pressures are not available on the multi-function display.

Light in instrument panel	Warning and information message in the multi-function display	Meaning/Action required
	 Tire pressure monitoring fault Service required	Fault in Tire Pressure Monitoring System. Tire pressure is not monitored. Have the fault corrected at an authorized Porsche dealer.
	 Tire pressure monitoring temporarily deactivated	Temporary fault in the Tire Pressure Monitoring System. Tire pressure is not monitored.
	 Tire change? Update settings	The tire settings on the multi-function display must be updated after changing a wheel.
		Race circuit mode active in Tire Pressure Monitoring System. Race circuit mode must not be used on public roads.
	 Tire pressure Reduce speed	Speed too high for actual pressure. Inflate tire to the required pressure.
		Driving light/side light on.
		Left/right parking light on.
	 Example: Check front left indicator	The reported light is faulty. Check bulb. Have the fault corrected at an authorized Porsche dealer.
 flashes	 Adaptive headlight control defective Service required	Have the fault corrected at an authorized Porsche dealer.
 lights up	 Driving light control defective Service required	Have the fault corrected at an authorized Porsche dealer.
	 Headlight range regulation defective Service required	Adjust your speed and driving style. Have the fault corrected at an authorized Porsche dealer.
	 Rain/light sensor defective Service required	Switch on wipers/light manually. Have the fault corrected at an authorized Porsche dealer.
 flashes	 Headlight control defective Service required	Have the fault corrected at an authorized Porsche dealer.

Light in instrument panel	Warning and information message in the multi-function display	Meaning/Action required
	 <p>Wiper defective Consult a workshop</p>	Have the fault corrected at an authorized Porsche dealer.
Example	 <p>Doors/lids open</p>	Close door/lid indicated.
	 <p>System fault Driving permitted Consult a workshop</p>	One or more electrical systems may have failed. Adapt your driving style and speed to the changed conditions. Have the fault corrected at an authorized Porsche dealer.
	 <p>Parking Assistant audio fault Service required</p>	Acoustic warning and distance signals for ParkAssist are not available. Please remember this, e.g. when parking. Have the fault corrected at an authorized Porsche dealer.
Warning light on the coolant temperature gauge flashes	 <p>Fault of the engine control system</p>	Have the fault corrected at an authorized Porsche dealer.
	 <p>Outside temp. display defective Service required</p>	Have the fault corrected at an authorized Porsche dealer.
	 <p>Example: Service in xxx km</p>	Service reminder. Bring the vehicle in for service no later than after the distance/time shown has elapsed. The intervals in the "Maintenance" booklet are decisive however.

Driving and Driving Safety

Diagnostic Socket	118
Ignition Lock	118
Starting and Stopping the Engine	119
Electric Parking Brake	120
Brakes	121
Cruise Control.....	124
Car Audio Operation/Tips	126
Porsche Communication Management (PCM).....	128
USB/iPod® and AUX.....	128
Voice Control.....	129
Porsche Track Precision App	129
Lap Trigger	130
Manual Transmission, Clutch.....	132
Transmission and Chassis Control Systems ..	134
Porsche Stability Management (PSM).....	135
ABS Brake System (Anti-Lock Brake System)	138
Porsche Active Suspension Management (PASM)	139
Porsche Torque Vectoring (PTV) Functional Description	140
Dynamic Engine Mounting (PADM)	140
“Sport” mode.....	141
Sports Exhaust System	141

Diagnostic Socket

⚠ WARNING

Improper interventions in the vehicle electrical system

External equipment or devices (e.g. navigation units, head-up displays, etc.) connected to the diagnostic socket can impair the function of the vehicle systems.

- ▷ Do not connect any equipment or devices to the diagnostic socket.

⚠ WARNING

Loose equipment/devices or hanging cables in the driver's footwell

Loose equipment/devices or hanging cables in the driver's footwell can obstruct clearance around the pedals or become caught between the pedals when braking or changing direction.

- ▷ Do not place any equipment/devices or cables in the driver's footwell.

NOTICE

The diagnostic socket is for connecting diagnostic equipment in qualified specialist workshops.

Operating external equipment or devices (e.g. navigation units, head-up displays, etc.) from the diagnostic socket when the ignition is switched off will run down the battery. If the vehicle is parked for an extended period, the battery can discharge fully and be damaged (exhaustive discharge).

- ▷ Do not connect any equipment or devices to the diagnostic socket.

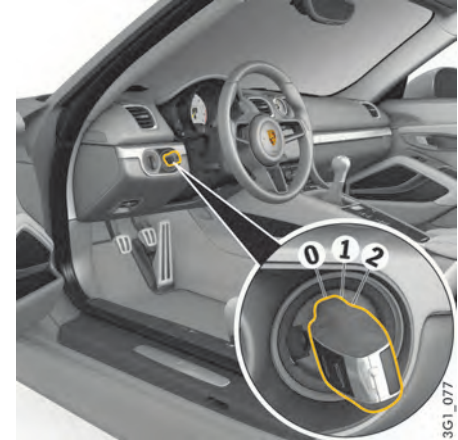
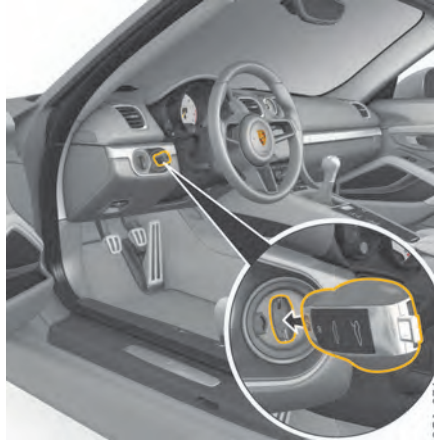

Ignition Lock

The ignition key is inserted into the ignition lock to the right of the light switch at the left of the steering wheel.

On vehicles **with Porsche Entry & Drive**, you no longer have to insert the key into the ignition lock, but merely keep it with you. The ignition key is replaced by a control unit in the ignition lock, which **always** remains in the ignition lock, unless the vehicle is being towed.

The ignition lock has three key positions.

Key positions

- 0** - Initial position
- 1** - Ignition on
- 2** - Start engine



Information

The vehicle battery discharges if the ignition key is left inserted.

If the vehicle battery is dead, the key can only be removed from the ignition lock if the emergency operation is performed:

- ▷ Please see the chapter "EMERGENCY OPERATION – UNLOCKING THE IGNITION KEY" on page 27.

Ignition lock position 0 – Ignition off (initial position)

The engine and ignition are off in ignition lock position **0**. The ignition key can be removed in this position.

Ignition lock position 1 – Ignition on

▷ Turn ignition key to position **1**.

All electrical equipment can be switched on. The warning lights on the instrument panel light up for a lamp check.

▷ Please see the chapter “INSTRUMENT PANEL USA MODELS” on page 74.

If a load is not switched on for 10 minutes after switching on the ignition, the ignition must be switched on again.

Turn the ignition key to ignition lock position **0** (initial position) first.

The ignition key cannot be removed when the ignition is switched on or when the engine has been started.

To remove the ignition key:

- ▷ Stop the vehicle.
- ▷ Switch ignition off.
- ▷ Remove the ignition key.

Ignition lock position 2 – Start engine

▷ Turn ignition key to ignition lock position **2**.

The key is reset automatically from position 2 to position 1 when you start the engine.

Starting and Stopping the Engine

The immobilizer can be deactivated and the engine started only using an authorized ignition key.

▷ Please see the chapter “IMMOBILIZER” on page 160.

WARNING

Exhaust gas

Exhaust gas contains colorless and odorless carbon monoxide (CO), which is toxic even in low concentrations. Carbon monoxide can cause unconsciousness and even death if inhaled.

▷ Never start or let the engine running in an enclosed, unventilated area. It is not recommended to sit in your car for prolonged periods with the engine on and the car not moving.

WARNING

Exhaust system fire hazard

Exhaust fumes and the exhaust system are very hot when the engine is running. The exhaust system remains hot for some time after the engine is turned off.

- ▷ Do not park or drive your vehicle where combustible materials, such as dry grass or leaves, can come into contact with the hot exhaust system.
- ▷ If your car catches on fire for any reason, call the fire department. Do not endanger your life by attempting to put out the fire.

NOTICE

An unattended vehicle with a running engine is potentially hazardous. If warning lights come on to indicate improper operation, no one would be present to observe the light and turn off the engine.

▷ Never leave the engine idling unattended.

Starting the vehicle

- ▷ Operate the footbrake.
- ▷ Fully depress the clutch pedal and keep it pressed
- ▷ Do not press the accelerator pedal. The engine control unit will provide the correct starting mixture.
- ▷ Do not operate the starter for more than approx. 10 seconds. If necessary, repeat the starting procedure after a pause of approx. 10 seconds. Turn the ignition key back to ignition lock position **0** (initial position) first. The first operation of the starter is ended automatically when the engine starts. If the engine does not start, subsequent starter operations will not be ended automatically.
- ▷ Do not warm up the engine when stationary. Drive off immediately. Avoid high revs and full throttle until the engine has reached operating temperature.
- ▷ If the vehicle battery power is too weak, the engine can be started with jump leads.

For information on jump-lead starting:

- ▷ Please see the chapter “EXTERNAL POWER SUPPLY, EMERGENCY STARTING WITH JUMPER CABLES” on page 207.

Information

To ensure a good battery charge condition, thereby ensuring that the battery will start the engine, all electrical loads that are not required should be switched off when the ignition is switched on and when engine revs are low (in traffic jams, in city traffic or in lines).

Stopping

- ▷ Only remove the ignition key when the vehicle is stationary.
- ▷ Only switch the ignition off when the vehicle is stationary, as there is no power steering and brake booster assistance when the engine is switched off.
- ▷ When leaving the vehicle, **always** remove the ignition key and apply the electric parking brake.

WARNING Hot engine parts

Engine components become very hot when the engine is running.

- ▷ Before working on any part in the engine compartment, turn the engine off and let it cool down sufficiently.
-

WARNING Hot exhaust tailpipe

The exhaust pipe is hot when the engine is running and remains hot for some time after the vehicle is turned off.

- ▷ To prevent injury, make a point of noting where your vehicle's exhaust pipe is, avoid placing your legs near the exhaust pipe when loading and unloading cargo in the rear, and closely supervise children around the vehicle during time when the exhaust pipe could be hot. A hot exhaust pipe can cause painful skin burns.
-

Radiator fan

WARNING Radiator fan

The fan can start running depending on the temperature, even with the engine switched off.

- ▷ Exercise extreme care that parts of the body, articles of clothing or jewelry do not get caught in the radiator fan.
 - ▷ Exercise extreme caution when working in the area of the radiator fans.
-

For information on radiator fans:

- ▷ Please see the chapter "RADIATOR FAN, ENGINE COMPARTMENT BLOWERS" on page 164.

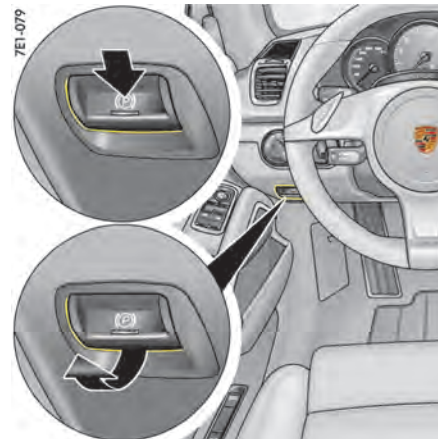

Electric Parking Brake

The electric parking brake acts on the rear wheels and serves to secure the vehicle while parked.

Applying the parking brake

- ▷ Press switch . The brake warning light on the instrument panel lights up.

For information on indicator lights and warning lights on the instrument panel:

- ▷ Please see the chapter "INSTRUMENT PANEL USA MODELS" on page 74.

Releasing the parking brake

The electric parking brake can only be released when the ignition is switched on.

1. Press the brake pedal.

2. Pull switch (P).

The brake warning light on the instrument panel goes out.

Automatic electric parking brake release when driver's intention to drive off is detected

If the engine is running, the driver's door is closed and the driver's safety belt is fastened, it is still possible to drive off normally even though the parking brake is on.

The electric parking brake detects the driver's intention to drive off and releases automatically. The warning light on the instrument panel goes out.

If the driver's door is not closed or the driver's safety belt is not fastened, the electric parking brake will not be released automatically when the driver attempts to drive off.

The message "**Release parking brake**" appears on the multi-function display in the instrument panel. The brake warning light on the instrument panel and the indicator light on the switch (P) start to flash.

For information on warning messages on the multi-function display:

- ▷ Please see the chapter "OVERVIEW OF WARNING AND INFORMATION MESSAGES" on page 109.

Emergency braking function

If the vehicle cannot be stopped by conventional braking, you can decelerate sharply and stop the vehicle using the electric parking brake.

- ▷ Press switch (P) and keep it pressed.

The brake warning light on the instrument panel and the indicator light on the switch (P) start to flash.

The emergency braking function is deactivated when you release the switch.



Information

Severe braking. Emergency braking takes place with very high braking power.

- ▷ Only use the emergency braking function in an emergency situation.
 - ▷ Do not use the emergency braking function to stop the vehicle when driving normally.
-

BRAKE Brake warning light USA

Brake warning light Canada

If the electric parking brake could not be applied fully when the vehicle is stopped, the brake warning light on the instrument panel starts to flash.

For information on warning messages on the multi-function display:

- ▷ Please see the chapter "OVERVIEW OF WARNING AND INFORMATION MESSAGES" on page 109.

Brakes

- ▷ Make it a habit to check the operation of your brakes before driving.

Keep in mind that the braking distance increases very rapidly as the speed increases. At 60 mph (100 km/h), for example, it is not twice but four times longer than 30 mph (50 km/h). Tire traction is also less effective when the roads are wet or slippery.

- ▷ Therefore, always maintain a safe distance from the car in front of you.

Vehicles without Porsche Ceramic Composite Brake (PCCB)

Even though the brake disks consist of alloyed gray cast iron, they will unavoidably start to corrode if your car is parked for an extended period. The brakes will tend to “rub” as a result. The nature, extent and effects of corrosion depend on the amount of time the vehicle was parked, whether road salt or grit was spread and whether grease-dissolving agents were used in car washes.

If the braking comfort is noticeably impaired, we recommend having the brake system checked by experts at an authorized Porsche dealer.

Brake system function

Your Porsche is equipped with a power assisted hydraulic dual circuit brake system with disk brakes at the front and rear.

Both circuits function independently. One brake circuit operates the front left and rear right wheel and the other operates the front right and rear left wheel.

If one brake circuit has failed, the other will still operate. However, you will notice an increased pedal travel when you apply the brakes. Failure of one brake circuit will cause the stopping distance to increase.

WARNING

Brake hydraulic failure recovery

Your vehicle is equipped with an emergency function in the extreme event of a complete hydraulic failure of the brake system. If your brake pedal goes all the way to the floor, do not pump the brakes.

- ▷ Push the brake pedal down firmly and hold it in that position. A mechanical linkage activates the second circuit, and you will be able to bring the vehicle to a stop.
- ▷ After bringing your vehicle to a complete stop, avoid driving the vehicle and instead have it towed to the nearest authorized Porsche dealer for repair.

Brake system warning light

You can check the functionality of the brake system warning light by switching the ignition to the “On” position (position **1**) and verifying that the warning light illuminates.

BRAKE Brake warning light USA

Brake warning light Canada

The warning light in the instrument panel lights up. A message will be displayed on the multi-function display of the instrument panel if the brake fluid level is too low, or (if the brake pedal travel has increased) one of the two brake circuits has failed.

A greater braking pressure will be required, stopping distances will be longer and the braking behavior will change, particularly in curves.

With correctly adjusted brakes and a correctly working brake system, the pedal travel to the point of brake application should be 1-3/16 in. to 1-9/16 in. (30 to 40 mm). Whenever the brake pedal travel exceeds this value, have the brake system checked.

Brake pedal

WARNING

Obstruction of brake pedal

Unsuitable or incorrectly fixed floor mats or objects can reduce the travel of the brake pedal or prevent from applying the brake pedal.

- ▷ Always check the movement of the brake pedal before driving and make sure that it is not obstructed by a floor mat or any other object.
- ▷ Secure the floor mat to prevent it from sliding into positions that could interfere with the safe operation of your vehicle. Your authorized Porsche dealer will be glad to offer you floor mats of the correct size including a securing possibility.

Information

In case one of the two brake circuits fails, increased pedal travel is required to bring your vehicle to a full stop.

⚠ WARNING**Riding the brakes**

- ▷ Before descending a steep grade, reduce speed and shift the transmission into a lower gear to control speed.
- ▷ Do not “ride the brakes” by resting your foot on the pedal when not intending to apply brake pressure.
- ▷ Do not hold the pedal down too long or too often. This could cause the brakes to overheat and lose braking power.

Brake booster**The brake booster assists braking only when the engine is running.**

When the car is moving while the engine is not running, or if the brake booster is defective, more pressure on the brake pedal is required to bring the car to a stop.

Moisture, road salt or grit on brakes affects braking.

Brakes will dry after a few cautious brake applications.

⚠ WARNING**Wet brakes**

Driving through water may reduce the traction. Moisture on brakes from road water, car wash, or a coating of road salt or grit may affect braking efficiency.

- ▷ Cautiously apply brakes to test and dry the brakes after exposure to road water, etc.

⚠ WARNING**Loss of braking power**

The brake booster is ready for operation only while the engine is running.

If the engine is switched off or there is a defect in the brake booster, much greater force has to be applied to the pedal when braking.

- ▷ Vehicles with defective brakes must not be towed and must be transported on a flat bed.

For information on towing:

- ▷ Please see the chapter “TOWING” on page 214.

Brake wear

Your car has excellent brakes, but they are still subject to wear. The rate at which they wear depends on how the brakes are used.

- ▷ Have the brake system inspected at the intervals recommended in your Maintenance Booklet.

Brake system warning light

You can check the functionality of the brake system warning light by switching the ignition to the “On” position (position **1**) and verifying that the warning light illuminates.

**Brake wear warning message USA****Brake wear warning message Canada**

A warning message will be displayed on the multi-function display of the instrument panel if the brake pads are worn, excessively.

- ▷ Adapt your driving style and speed to the changed conditions.
- ▷ Have your authorized Porsche dealer inspect or replace the brake pads.

For information on warning messages on the multi-purpose display:

- ▷ Please see the chapter “OVERVIEW OF WARNING AND INFORMATION MESSAGES” on page 109.

Brake pads and brake disks

Wear on the brake pads and brake disks depends to a great extent on the driving style and the conditions of use and therefore cannot be expressed in actual miles on the road.

The high-performance brake system is designed for optimal braking effect at all speeds and temperatures.

Certain speeds, braking forces and ambient conditions (e.g. temperature and humidity) can therefore cause the brakes to “squeal”.

⚠ WARNING**Obstructed brake pedal**

Unsuitable or incorrectly installed floor mats or objects can obstruct the movement of the brake pedal or prevent application of the brake pedal.

- ▷ Do not obstruct the pedal travel with floor mats or other objects.

⚠ WARNING

Wet brakes

In heavy rain, while driving through water or after leaving a car wash, the braking action may be delayed and increased pressure may be required.

- ▷ For this reason, keep further back from the vehicle in front and “dry” the brakes by applying them at intervals. Make sure that the traffic behind you is not affected.

⚠ WARNING

Reduced braking efficiency

After a long drive over salted or gritted roads, a coating may form on the brake disks and pads that significantly reduces friction and therefore also braking effect.

- ▷ Even though the brake disks consist of alloyed gray cast iron, they will unavoidably start to corrode if your vehicle is parked for an extended period. The brakes will tend to “rub” as a result.

The nature, extent and effects of corrosion depend on the amount of time the vehicle was parked, whether road salt or grit was spread and whether grease-dissolving agents were used in car washes (not on vehicles with Porsche Ceramic Composite Brake).

To prevent corrosion of the brake disks, “brake them dry” before parking the vehicle (not on vehicles with Porsche Ceramic Composite Brake).

If braking comfort is noticeably impaired, we recommend that you have the brake system checked by experts at an authorized Porsche dealer.

- ▷ To relieve the brake system on downhill stretches, change down to a lower gear in good time (engine braking). If engine braking is insufficient on steep stretches, operate the footbrake at intervals. Avoid continuous braking as it overheats the brakes and reduces the braking effect.

For information on brake fluid and checking the brake fluid level:

- ▷ Please see the chapter “BRAKE FLUID” on page 185.

New brake pads or linings

New brake pads have to be “broken in”, and therefore only attain optimal friction when the car has covered several hundred miles or km.

The slightly reduced braking ability must be compensated for by pressing the brake pedal harder. This applies whenever the brake pads and/or brake disks are replaced.

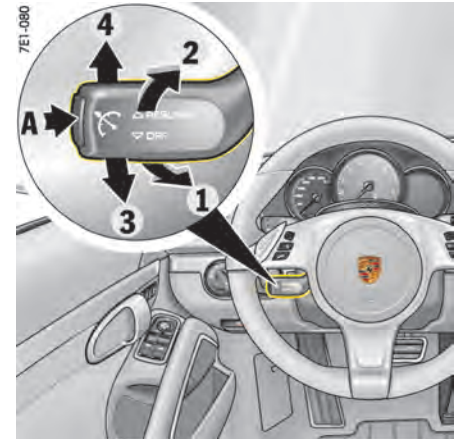

- A** - Switch cruise control on/off
- 1** - Set/increase desired speed
- 2** - Reduce desired speed
- 3** - Interrupt (OFF)
- 4** - Return to set speed (RESUME)

Cruise Control

Cruise control maintains any selected speed between approx. 20–150 mph (30–240 km/h) without you having to use the accelerator.

Cruise control is operated using the control stalk at the bottom left of the steering wheel.

WARNING

Misuse of cruise control

If the current traffic situation does not allow you to drive safely at a constant speed and with sufficient distance to the vehicle in front, using the cruise control can cause accidents.

- ▷ Do not use the cruise control in heavy traffic, in city traffic, on twisting roads or under unfavorable road conditions (e.g. wintry or wet conditions, varying road surfaces).
- ▷ Observe all local and national speed limits.
- ▷ Do not reach through the steering-wheel spokes while driving.

Switching cruise control readiness on

- ▷ Press button **A** on the control stalk.



Cruise control readiness

The grey symbol on the multi-function display in the instrument panel indicates readiness.

Maintaining and storing speed

1. Accelerate or decelerate to the desired speed using the accelerator pedal.
2. Push the control stalk on the steering wheel forward (position **1**).
The current driving speed is now stored as the desired speed, which will be maintained automatically.



Desired speed

The desired speed that was stored is displayed under the cruise control symbol, which has now turned orange.

Accelerating (e.g. to overtake)

Variant 1

- ▷ Increase the speed as usual with the accelerator pedal.
When you ease off the accelerator, the previously stored value is set again.

Variant 2

- ▷ Push the control stalk on the steering wheel forward (position **1**).
The desired speed is increased in steps of 1 mph (1 km/h).
or
Press the control stalk on the steering wheel forward and keep it pressed (position **1**).
The desired speed is increased in steps of 5 mph (10 km/h).

The new desired speed is displayed on the multi-function display in the instrument panel.

Decelerating

- ▷ Briefly pull the control stalk on the steering wheel towards the steering wheel (position **2**).
The desired speed is decreased in steps of 1 mph (1 km/h).
or
Pull the control stalk on the steering wheel towards the steering wheel and keep it pulled (position **2**).
The desired speed is decreased in steps of 5 mph (10 km/h).

The new desired speed is displayed on the multi-function display in the instrument panel.

Interrupting cruise control operation – OFF

The speed driven before the interruption remains stored in the memory and can be reactivated by pressing the control stalk.

- ▷ Please see the chapter “RESUMING THE STORED SPEED – RESUME” on page 126.
- ▷ Press the control stalk down (position **3**).

Cruise control operation is interrupted automatically:

- If the set vehicle speed is exceeded by more than approx. 16 mph (25 km/h) for longer than 20 seconds.
- If the actual vehicle speed falls below the set vehicle speed by approx. 37 mph (60 km/h) for longer than 60 seconds (e.g. gradients).
- If Porsche Stability Management (PSM) intervenes for longer than 0.5 seconds.

Resuming the stored speed – RESUME

- ▷ Press the control stalk up (position 4).
Cruise control accelerates/decelerates the vehicle to the stored speed.



Information

The stored speed should only be recalled if traffic and road conditions are conducive to driving at that speed.

Switching cruise control readiness off

- ▷ Press button **A** on the control stalk.
The memory is cleared and the readiness symbol disappears.
- The stored desired speed is cleared when the ignition is switched off when the vehicle is parked.



Information

On upward or downward slopes, the set speed cannot always be maintained by cruise control (vehicles with manual transmission).

- ▷ To obtain sufficient engine braking or a better rev range, you therefore have to change down to a lower gear.
-

Car Audio Operation/Tips

For radio operation see your radio manual which is included with your on-board literature.

FM reception

A vehicle is not an ideal place to listen to a radio. Because the vehicle moves, reception conditions are constantly changing.

Buildings, terrain, signal distance and noise from other vehicles are all working against good reception.

Some conditions affecting FM may appear to be problems when they are not.

The following characteristics are completely normal for a given reception area, and they do not indicate any problem with the radio itself.



Information

Electronic accessories should only be installed by your authorized Porsche dealer.

Equipment which has not been tested and approved by Porsche may impair radio reception.

Fading and drifting

FM range is limited to about 25 miles (40 km), except for some high power stations.

If a vehicle is moving away from the desired station's transmitter, the signal will tend to fade and/or drift. This condition is more prevalent with FM than AM, and is often accompanied by distortion.

Fading and drifting can be minimized to a certain degree by careful attention to fine tuning or selection of a stronger signal.

Static and fluttering

When the line-of-sight link between a transmitter and vehicle is blocked by large buildings or mountains, the radio sound may be accompanied with static or fluttering because of the characteristic of FM.

In a similar effect, a fluttering noise is sometimes heard when driving along a tree-lined road.

This static and fluttering can be reduced by adjusting the tone control for greater bass response until the disturbance has passed.

Multipath

Because of the reflecting characteristics of FM, direct and reflected signals may reach the antenna at the same time (multipath) and cancel each other out. As a vehicle moves through these electronic dead spots, the listener may hear a momentary flutter or loss of reception.

Station swapping

When two FM stations are close to each other, and an electronic dead spot, such as static or multipath area, interrupts the original signal, sometimes the stronger second signal will be selected automatically until the original one returns. This swapping can also occur as you drive away from the selected station and approach another station of a stronger signal.



Compact disk player

NOTICE

To avoid damage to compact disk player and disks.

- ▷ Use only compact disks labeled as shown, having no dirt, damage or warpage.
- ▷ Never attempt to disassemble or oil any part of the player unit. Do not insert any object other than a disk into the slot. Remember there are no user-serviceable parts inside the compact disk player.
- ▷ Do not allow the disk to sustain any fingerprints, scrapes or stickers on the surfaces. This may cause poor sound quality. Hold the disk only on the edge or center hole.
- ▷ When not in use, take the disk out of the player, put the disk back into its case and store it away from dust, heat, damp and direct sunlight.
Leaving the disk on the dashboard in the sun can damage the disk.
- ▷ If the disk gets dirty, clean the disk by wiping the surfaces from the center to the outside in a radial direction with a soft cloth.
Do not use a conventional record cleaner or anti-static record preservative.
Disk cleaners are available in audio stores.

Car Telephone and Aftermarket Alarms

Important legal and safety information regarding the use of cellular telephones

Some jurisdictions may prohibit the use of cellular telephones while driving a vehicle. Check the laws

and regulations on the use of cellular telephones in the areas where you drive.



Cell phone use

Looking away from the road or turning your attention away from your driving to operate a cell phone will sooner or later cause an accident.

- ▷ Do not attempt to operate a hand-held cell phone while you are driving. Safety is more important than a phone call.
- ▷ Learn to operate the hands-free phone, if it is available, before you start driving. Then make use of the hands-free phone at all times.

It is essential to observe the telephone manufacturer's instructions before operating the telephone.

Any portable telephone or radio transmitter which is used in a Porsche must be properly installed in accordance with the technical requirements of Porsche.

The transmission power must not exceed 10 W.

The devices must possess a type approval for your vehicle and have an **"e" symbol**.

If you should require equipment with transmission power values greater than 10 W, please consult your authorized Porsche dealer for this purpose. They are familiar with the technical requirements for installing devices of this kind.

The antennas for all radios and telephones with a transmitting antenna must be externally mounted.

The improper installation of radios or telephones or use of a radio or telephone with a transmitting antenna inside the car may cause **the warning lights to come on**.

Improper installation of such equipment can create a discharged battery or excessive current draw from added equipment.

If aftermarket systems are installed by non-dealership technicians or outside the selling dealer, problems may result. Installation of aftermarket equipment is not covered under the New Car Warranty.

- ▷ Consult your authorized Porsche dealer about the installation of non-Porsche approved equipment.

Reception quality

The reception quality of your car telephone will change constantly when you are driving. Interference caused by buildings, landscape and weather is unavoidable. It may become particularly difficult to hear when using the hands-free function due to external noise such as engine and wind noise.

Automatic car-wash

- ▷ Unscrew external antennas before using an automatic car-wash.

Porsche Communication Management (PCM)

WARNING

Operation of on-board systems

Setting or operating the multi-function display, radio, navigation system, telephone or other equipment when driving could distract you from the traffic. You could lose control of the vehicle.

- ▷ Operate the components while driving only if the traffic situation allows you to do so safely.
 - ▷ Carry out any complicated operating or setting procedures only with the vehicle stationary.
 - ▷ If it is necessary to operate these components while the vehicle is in motion, use the function keys on the multi-functional steering wheel.
-
- ▷ Refer to the separate operating instructions before putting the PCM into operation.

When put into operation for the first time, a distance of approx. 3 miles (5 km) must be driven in order for the navigation system to complete the process of fine calibration. The same applies when the tires are changed (e.g. summer/snow tires) or new tires fitted. Full location accuracy is not yet achieved during the fine-calibration process.

If the vehicle has been transported (e.g. ferry, car train), the system may take a few minutes after being switched on before it determines the current location.

Serious tire slip (e.g. spinning wheels on snow) may result in temporarily inaccurate navigation. When the battery has been disconnected, it may take up to 15 minutes before the navigation system is operational once more.

Satellite radio

You must have the satellite radio activated before you can put it into operation. You will need a contract with a provider in order to use this radio.

- ▷ Refer to the separate radio operating instructions before putting into operation.



USB/iPod® and AUX

The USB/iPod® and AUX interfaces are located in the glove box.

- ▷ Please refer to the chapter “EXTERNAL AUDIO SOURCE” in the separate PCM operating instructions.



Information

Do not leave your iPod®, USB storage device or an external audio source in the vehicle for extended periods of time because extreme ambient conditions (temperature fluctuations, humidity) can occur in the vehicle.



Voice Control

Porsche Communication Management (PCM) can be operated by spoken commands using the voice control system.

- ▷ Please refer to the chapter “VOICE CONTROL” in the separate PCM operating instructions.

Activating voice control

- ▷ Press button . An acoustic signal sounds and help text for using the five most important voice commands appears on the multi-function display in the instrument panel. Simply say the command.

For information on switching the help text on and off on the multi-function display:

- ▷ Please see the chapter “DISPLAYING PCM INFORMATION ON THE MULTI-FUNCTION DISPLAY” on page 101.

Porsche Track Precision App

USA: QZ9-APPGATEWAY

Canada: 5927A-APPGATEWAY

This device complies with Part 15 of the FCC Rules (and with Industry Canada licence-exempt RSS standard(s)).

Operation is subject to the following two conditions:

1. This device may not cause harmful interference, and
2. this device must accept any interference received, including interference that may cause undesired operation.

Changes or modifications made to this equipment not expressly approved by Porsche may void the FCC authorization to operate this equipment.

This equipment has been tested and found to comply with the limits for a Class B digital device, pursuant to Part 15 of the FCC Rules.

These limits are designed to provide reasonable protection against harmful interference in a residential installation.

This equipment generates, uses and can radiate radio frequency energy and, if not installed and used in accordance with the instructions, may cause harmful interference to radio communications. However, there is no guarantee that interference will not occur in a particular installation.

If this equipment does cause harmful interference to radio or television reception, which can be determined by turning the equipment off and on, the user is encouraged to try to correct the interference by one or more of the following measures:

- Reorient or relocate the receiving antenna.
- Increase the separation between the equipment and receiver.
- Connect the equipment into an outlet on a circuit different from that to which the receiver is connected.
- Consult the dealer or an experienced radio/TV technician for help.



Information

Radiofrequency radiation exposure: The radiated output power of the device is far below the FCC radio frequency exposure limits. Nevertheless, the device shall be used in such a manner that the potential for human contact during normal operation is minimized.

The Porsche Track Precision app can be used to connect to the vehicle via a wireless local network (WLAN). This enables driving data to be displayed, recorded and analysed directly on a smartphone. Detailed information on installation and the functions of the Porsche Track Precision app is available directly in the app and at www.porsche.com or from your authorized Porsche dealer.

⚠ DANGER

Loss of control over the vehicle

Driving at excessive speeds and risky maneuvers may lead to loss of control over the vehicle.

- ▷ Adapt your driving style and maneuvers to your personal ability, the road and weather conditions, as well as the traffic situation.
- ▷ Only use the Porsche Track Precision app on closed circuits away from public roads.

⚠ DANGER

Setting and operating when driving

Use of the app while driving can distract your attention from the road. You may lose control of the vehicle.

- ▷ Carry out operating and setting procedures only whilst the vehicle is stationary.



Information

Since vehicle-specific data can be accessed using the Porsche Track Precision app, it is recommended to protect this data from unauthorized access by third parties.

Lap Trigger

The lap trigger enables lap times to be automatically measured. The system consists of an infrared transmitter positioned at the edge of the circuit and an infrared receiver mounted in the vehicle.

Technical data

Permissible voltage range of the transmitter	11 V to 16 V
Power consumption of the transmitter	1.2 W
Permissible temperature range of the receiver	50 °F (10 °C) to 140 °F (60 °C)

Notes on the receiver

- The receiver can be installed on the left or right in the vehicle depending on the race circuit.
- To guarantee optimum reception, there must be a direct line of sight between the receiver and transmitter.
- Direct sunlight hitting the receiver will interfere with reception.

NOTICE

Ambient temperatures of below 50 °F (10 °C) can cause permanent damage to the receiver.

- ▷ Remove the receiver from the vehicle if the ambient temperature is below 50 °F (10 °C).

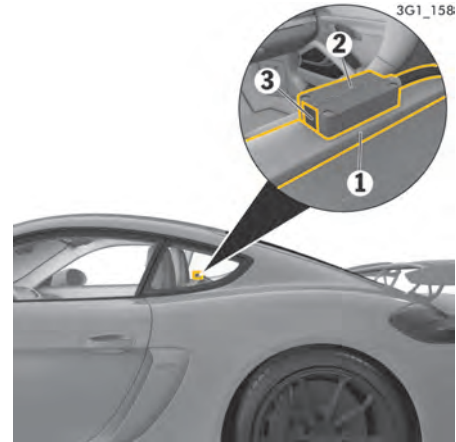

Installing the receiver

- ▷ Mount the receiver **2** horizontally on the bracket **1**. The receiver eye **3** should be pointing out of the rear side window.

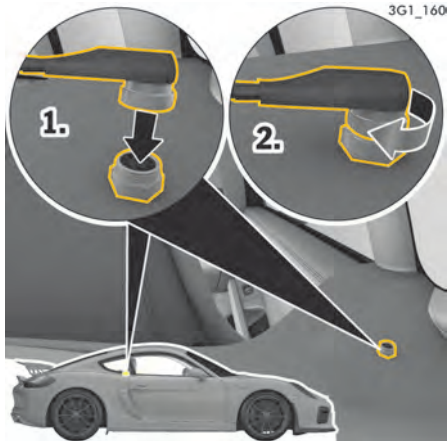

Connecting the receiver

1. Insert the receiver cable into the socket behind the passenger seat.
2. Screw the connector onto the socket.

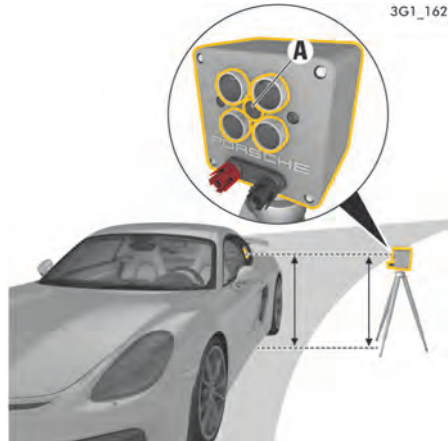

Installing the transmitter at the edge of the circuit

Information

If multiple vehicles with the Porsche lap trigger system will be driving on a race circuit, only one transmitter should be installed. The receiver cannot differentiate the transmitters and detects each passing of a transmitter as a new lap.

A commercially available camera tripod, for example, can be used for adjusting the transmitter height.

Alternatively the transmitter can be placed on a flat, firm surface.

NOTICE

Risk of damage to the transmitter

The airflow from passing vehicles can cause the transmitter to fall down or over.

▷ Choose the transmitter location so that a safe, firm position is guaranteed.

1. Position transmitter **A** at the edge of the circuit at the start line at the same level as the receiver in the vehicle.
2. Align transmitter **A** parallel to the track.

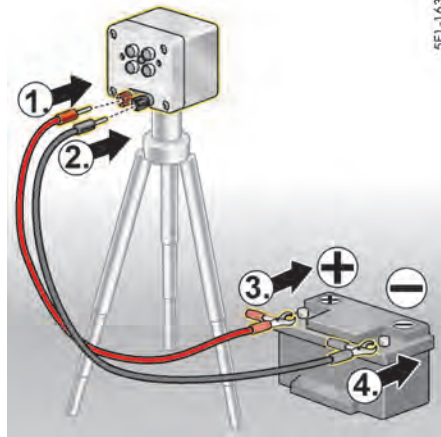

SF1-163

1. Insert the red cable into the red connection on the transmitter.
2. Insert the black cable into the black connection on the transmitter.
3. Connect the red cable to the positive terminal (+) of the battery.
4. Connect the black cable to the negative terminal (-) of the battery.

Starting timing

The first lap must be manually started in the **“Chrono”** menu on the multi-function display. The lap times are then recorded automatically. For instructions on starting the timing:
 ▷ Please see the chapter **“STARTING TIMING”** on page 93.

Connecting the power supply for the transmitter

A commercially available motorcycle or car battery, for example, can be used for the power supply to the transmitter.

- ▷ Make sure that the battery is sufficiently charged.

NOTICE

Risk of damage due to short circuit.

- ▷ Keep the battery dry.
- ▷ Make sure the polarity is correct.



Manual Transmission, Clutch

⚠ WARNING

Blocked pedals

Unsuitable or improperly secured floor mats or objects can restrict pedal travel or hinder pedal operation.

- ▷ Do not obstruct the pedal travel with floor mats or other objects.
Nonskid floor mats of the correct size are available at your authorized Porsche dealer.

The positions of the gears are shown on the shift pattern on the gearshift lever.

- ▷ When changing gears, always ensure that the clutch pedal is fully depressed and the gear has engaged fully.
- ▷ Select reverse gear only when the vehicle is stationary.
Reverse gear can be engaged after moving the gearshift lever to the left past the stop.

- ▷ Select an appropriately low gear on upward and downward slopes.
This will ensure optimum use of engine power and engine braking.
- When reverse gear is selected and the ignition is on, the reversing lights come on.



Upshift prompt for fuel-economy-optimised driving

The consumption-oriented upshift indicator **A** in the tachometer at the right beside the digital speed display helps you to develop a fuel-saving driving style.

The upshift indicator lights up – prompting you to shift up to the next-higher gear – depending on the selected gear, engine speed and accelerator pedal position.

- ▷ Change to the next-higher gear when the upshift indicator lights up.

Gear display

The gear display **B** in the tachometer indicates the currently engaged gear.

Permitted engine speed

- ▷ You should change into a higher gear or ease off the accelerator before the needle reaches the red mark on the tachometer.

If the red zone is reached during acceleration, fuel feed is interrupted.

NOTICE

Risk of engine damage (overrevving) when shifting down to a lower gear.

- ▷ Take care not to exceed the maximum permitted engine speed when shifting down.

Transmission and Chassis Control Systems

Your Porsche sports car features a complex integrated system made up of all control systems acting in power transmission and in the chassis.

All control systems are networked with the aim of combining the best possible driving performance with maximum safety.

The following systems are involved:

System/designation	Scope
PSM Porsche Stability Management	<ul style="list-style-type: none">– Driving stability control– Anti-lock brake system (ABS)– Brake booster (Hydraulic Brake Assist)– Automatic brake differential (ABD)– Anti-slip control (ASR)– Engine drag torque control (MSR)– Drive-Off Assistant
PASM Porsche Active Suspension Management	<ul style="list-style-type: none">– Shock absorber system with adaptive, continuous shock absorber control
PTV Porsche Torque Vectoring	<ul style="list-style-type: none">– Laterally dynamic braking intervention for more agile cornering– Rear differential lock with fixed asymmetrical locking ratio

⚠ WARNING**Driver responsibility**

Despite the advantages of transmission and chassis control systems, it is still the driver's responsibility to adapt his driving style and maneuvers in line with road and weather conditions, as well as the traffic situation.

The increased safety that is provided should not induce you to take greater risks with your safety. The limits set by the physics of driving cannot be overcome.

These systems cannot reduce the risk of accidents due to inappropriate speed.

- ▷ Adapt your driving style, maneuvers and speed to the road and weather conditions, as well as the traffic situation.
-

Porsche Stability Management (PSM)

PSM is an active control system for stabilization of the vehicle during extreme driving maneuvers.

PSM makes use of both the automatic brake differential (ABD) and anti-slip regulation (ASR) systems, as well as the functions of the anti-lock brake system (ABS) and engine drag torque control system (MSR).

⚠ WARNING

Loss of control over the vehicle

In spite of the advantages of PSM, it is still the driver's responsibility to adapt his driving style and maneuvers in line with road and weather conditions, as well as the traffic situation.

The increased safety that is provided should not induce you to take greater risks with your safety. The limits set by the physics of driving cannot be overcome, even with PSM.

Risk of accidents due to inappropriate speed cannot be reduced by PSM.

Advantages of PSM

- Best possible traction and lane-holding ability – even on road surfaces with varying friction.
- The system compensates for undesired vehicle reactions (Ferraria effect) when the driver releases the accelerator pedal or brakes on bends. This compensation functions up to the maximum lateral acceleration.
- PSM actively stabilizes the vehicle if necessary during dynamic driving maneuvers (e.g. rapid steering movements, during lane changes, or on alternating bends).

- Improved braking stability on bends and on different or varying road surfaces.
- Improved brake function and shorter stopping distance in the event of emergency braking.

Readiness for operation

PSM is switched on automatically every time you start the engine.

Function

Sensors at the wheels, brakes, steering system and engine continuously measure:

- Speed
- Direction of travel (steering angle)
- Lateral acceleration
- Axial acceleration
- Rate of turn about the vertical axis

PSM uses these values to determine the direction of travel desired by the driver.

PSM intervenes and helps to correct the course if the actual direction of motion deviates from the desired course (steering-wheel position):

It brakes individual wheels as required.

If necessary, PSM also influences the engine power.

The events below inform the driver of PSM control operations and warn him to adapt his driving style to the road conditions:

- PSM warning light on the instrument panel flashes.
- Hydraulic noises can be heard.
- The vehicle decelerates and steering-wheel forces are altered as PSM controls the brakes.
- Reduced engine power.
- The brake pedal pulsates and its position is changed during braking.

In order to achieve full vehicle deceleration, foot pressure must be increased after the brake pedal has begun vibrating.

Examples of PSM control operations

- If the “front wheels of the vehicle drift” on a bend, the engine power is reduced and the rear wheel on the inside of the bend is braked if necessary.
- If the rear of the vehicle swings out on a bend, the front wheel on the outside of the bend is braked.
- Brake booster (Hydraulic Brake Assist): In the event of an emergency braking operation where the pedal force is insufficient, a brake booster provides the braking pressure necessary for maximum deceleration at all 4 wheels.

Automatic brake differential (ABD)

The ABD system controls the front and rear axles separately. If one wheel of an axle starts to spin, it is braked so that the other wheel on the same axle can be driven.

ABD recognizes different driving states, and it features control strategies adapted to these states. In situations in which little propulsive power is required, such as when the vehicle moves off on a level gravel surface, traction control already becomes active at low engine speeds. If a large amount of propulsive power is required, e.g. when driving off on an uphill slope or for rapid acceleration, the ABD system is adapted accordingly.

Anti-slip control (ASR)

The anti-slip control system prevents the wheels from spinning by adjusting the engine power, thereby ensuring good lane-holding ability and stable handling.

Engine drag torque control (MSR)

In conditions of excessive slip, the engine drag torque control system prevents all driven wheels from locking up when the vehicle is overrunning. This is also the case for downshifts on a slippery road.

Switching off PSM

PSM can be switched off in 2 stages:

- Stage 1 **ESC OFF**:
Switch off Electronic Stability Control (ESC).
- Stage 2 **ESC+TC OFF**:
Also switch off Traction Control (TC).

WARNING

No Brake Control in
Switch-Off Stages

There is no stabilizing brake control in either of the switch-off stages (even when the brakes are used).

- ▷ PSM should always be switched on during “normal” driving. This particularly applies in wet conditions.

However, it may be a good idea to switch off PSM temporarily in exceptional situations:

- On a loose surface and in deep snow.
- When “rocking the vehicle free”.



Switching off Electronic Stability Control (ESC)

Condition: Indicator light on the ESC+TC OFF button is off.

- ▷ Press button **ESC OFF**.
Electronic Stability Control (ESC) is switched off after a short delay.
When the system is switched off, the indicator light on the button and the PSM OFF warning light on the speedometer light up.
The message **“ESC switched off”** appears on the multi-function display in the instrument panel for approx. 4 seconds.
An acoustic signal also sounds.

i Information

- When Electronic Stability Control (ESC) is switched off, sportier Traction Control is activated.
- Brake interventions are deactivated.
- The ABS remains active.

Switch Electronic Stability Control (ESC) back on

- ▷ Press button **ESC OFF**.
Electronic Stability Control (ESC) is active immediately.
The indicator light on the button and the PSM OFF warning light on the tachometer go out.
The message **“ESC switched on”** appears on the multi-function display in the instrument panel for approx. 4 seconds.



Switching off Electronic Stability Control (ESC) and Traction Control (TC)

- ▷ Press button **ESC + TC OFF**.
Electronic Stability Control (ESC) and Traction Control (TC) switch off completely after a short delay.
When the system is switched off, the indicator light on the button and the PSM OFF warning light on the tachometer and TC OFF warning light on the speedometer light up.
The message **“ESC + TC switched off”** appears on the multi-function display in the instrument panel for approx. 4 seconds.
A gong signal also sounds.



Information

- All PSM functions are deactivated.
- ABS remains active.
- If PSM is deactivated directly using the ESC+TC OFF button, the indicator light on the ESC button also lights up.



Switching Electronic Stability Control (ESC) and Traction Control (TC) back on

- ▷ Press button . PSM is active immediately. The indicator light on the button, the PSM OFF warning light on the tachometer and the TC OFF warning light on the speedometer go out. The message **“ESC + TC switched on”** appears on the multi-function display in the instrument panel for approx. 4 seconds.



Information

When PSM is switched off, Traction Control (TC) can be switched on separately:

- ▷ Press button . Traction Control (TC) is active immediately. The indicator light on the  button and the TC OFF warning light on the speedometer go out. Electronic Stability Control (ESC) remains switched off.



PSM warning light

- The PSM warning light on the instrument panel lights up for a lamp check when the ignition is switched on.
- The light indicates PSM control operations, e.g. brake control in the event of one-sided wheel spin.
- The light – in conjunction with the multi-function display – indicates a fault. The warning message **“ESC + TC failure Adapted driving permitted”** appears on the multi-function display in the instrument panel.

For information on warning messages on the multi-function display:

- ▷ Please see the chapter “OVERVIEW OF WARNING AND INFORMATION MESSAGES” on page 106.
- ▷ Adapt your driving style and speed to the changed conditions.
- ▷ Contact a qualified specialist workshop in order to correct the fault. We recommend that you get an authorized Porsche dealer to do this work as they have trained workshop personnel and the necessary parts and tools.

Towing

For information on towing:

Please see the chapter “TOWING” on page 230. Additional steering forces also assist the driver during countersteering.

ABS Brake System (Anti-Lock Brake System)



WARNING

Loss of control over the vehicle

In spite of the advantages of ABS, it is still the driver's responsibility to adapt his driving style and maneuvers in line with road and weather conditions, as well as the traffic situation.

The increased safety that is provided should not induce you to take greater risks with your safety. The limits set by the physics of driving cannot be overcome, even with ABS.

Risk of accidents due to inappropriate speed cannot be reduced by ABS.

ABS ensures

- **Full steering control**
Vehicle remains steerable
- **Good driving stability**
No skidding due to locked wheels
- **Optimum braking distance**
Shorter stopping distance in most cases
- **Prevention of wheel locking**
No flat spots on the tires

Function

The decisive advantage of ABS lies in the driving stability and manoeuvrability of the vehicle in hazardous situations.

ABS prevents locking of the wheels during full braking, on almost all road surfaces, until just before the vehicle stops.

ABS begins to control the braking process as soon as a wheel shows a tendency to lock.

This controlled braking process is comparable with extremely rapid cadence braking.

The pulsating brake pedal and a “juddering noise” warn the driver to adapt his driving speed to the road conditions.

- ▷ If full braking is necessary, press the brake pedal fully during the whole braking operation, even though the pedal is pulsating. Do not reduce brake pressure.

ABS Warning light USA

Warning light Canada

If the ABS warning light lights up on the instrument panel while the engine is running, the ABS has switched off because of a fault.

The warning message “**ABS/PSM failure Adapted driving permitted**” appears on the multi-function display in the instrument panel.

For information on warning messages on the multi-function display:

- ▷ Please see the chapter “OVERVIEW OF WARNING AND INFORMATION MESSAGES” on page 109.

In this case, the braking system will operate **without lock prevention**, as in vehicles without ABS.

- ▷ Adapt your driving style to the changed braking behavior.

The ABS must be checked by your Porsche

dealer in order to prevent the occurrence of further faults with unpredictable consequences.

Please contact a qualified specialist workshop. We recommend that you get an authorized Porsche dealer to do this work as they have trained workshop personnel and the necessary parts and tools.

The ABS control unit is adjusted for the approved tire dimensions.

The use of tires with non-approved dimensions can lead to different wheel speeds, causing ABS to switch off.

Porsche Active Suspension Management (PASM)

The PASM system actively adjusts the shock absorbers. The adjustable damper system selects the appropriate damping level for each wheel according to the driving situation and driving conditions. Driving safety, agility and comfort are optimised.

Two different chassis setups can be selected at the push of a button:

- “Chassis Normal”
- “Chassis Sport”

In Normal mode, the chassis is in a basic setup for public roads and race circuits with uneven surfaces.

Sport mode provides a shock absorber tuning for particularly high driving dynamics (e.g. on even race circuits).

In addition to manual mode selection, PASM also adjusts shock absorber tuning for either sporty or comfort driving, depending on the driving situation.



Selecting the PASM mode

1. Switch on ignition.
2. Press button  (repeatedly).

On the button:

- **No indicator light** comes on when “Chassis Normal” is selected (default setting).
- **An indicator light** comes on when “Chassis Sport” is selected.

In addition, the selected chassis setup is shown on the multi-function display in the instrument panel for approx. 4 seconds.



Information

The last selected chassis setup is stored in the memory after the ignition is switched off.

Warning message

The system automatically detects PASM faults and displays them on the multi-function display in the instrument panel.

For information on warning messages on the multi-function display:

- ▷ Please see the chapter “OVERVIEW OF WARNING AND INFORMATION MESSAGES” on page 109.
- ▷ Adapt your driving style according to the changed conditions.
- ▷ Contact an authorized Porsche dealer in order to correct the fault.

Porsche Torque Vectoring (PTV) Functional Description



WARNING

Loss of control over the vehicle

Despite the advantages of PTV, it is still the driver's responsibility to adapt his/her driving style and maneuvers in line with road and weather conditions, as well as the traffic situation.

The increased safety that is provided should not induce you to take greater risks with your safety. The limits set by the physics of driving cannot be overcome, even with PTV.

Risk of accidents due to inappropriate speed cannot be reduced by PTV.

Porsche Torque Vectoring (PTV)

PTV consists of a control system for driving-dynamics relevant brake interventions enabling variable drive-torque distribution at the rear axle in conjunction with a mechanical rear-axle differential lock.

By using gentle braking interventions that are imperceptible to the driver at the rear wheel on the inside of the bend, PTV improves steering performance and steering precision. The vehicle follows the steering angle of the front wheels more precisely. Understeer is largely prevented in the limit range. This increases the lateral acceleration potential and higher cornering speeds are possible.

The mechanical rear-axle differential lock additionally improves traction in the event of wheel spin. It reduces load alteration effects during rapid cornering and increases driving stability at higher speeds.

Dynamic Engine Mounting (PADM)

On vehicles with Sport Chrono package

Dynamic Engine Mounting with variable damping is a system designed to enhance both driving dynamics and driving comfort. Depending on the driving situation, the ideal mounting rigidity and damping is automatically set in the range between a rigid engine-to-body connection (increase in driving dynamics) and decoupling of the engine from the body (increase in driving comfort).

Warning message

Dynamic engine mounting faults are indicated by a warning message on the on-board computer.

- ▷ Please see the chapter “OVERVIEW OF WARNING AND INFORMATION MESSAGES” on page 109.



“Sport” mode

“Sport” mode activates the throttle-blipping function. During downshifts, controlled revving up ensures optimum speed compensation and therefore greater vehicle stability during load changes.

Switching “Sport” mode on and off

- ▷ Press the **SPORT** button.

When “Sport” mode is switched on, the indicator light on the button lights up.

The word “SPORT” appears on the digital speedometer.

Switching “Sport” mode on and off has no influence on the PASM mode.

Warning messages

The warning message “**Sport mode not available**” appears on the multi-function display in the instrument panel in the event of a fault.

For information on warning messages on the multi-function display:

- ▷ Please see the chapter “OVERVIEW OF WARNING AND INFORMATION MESSAGES” on page 109.

Information

After the ignition is switched off, Sport mode is automatically reset to Normal mode.

- ▷ Please see the chapter “PORSCHE ACTIVE SUSPENSION MANAGEMENT (PASM)” on page 139.



Sports Exhaust System

Switching on and off

The sports exhaust system can be switched to a sound-optimized mode when the ignition is switched on.

- ▷ Press button .

When the sports exhaust system is switched on, the indicator light on the button lights up.

Storage and Luggage Compartment

Storage	143
Drinks Holder/Cupholder	144
Ashtray	146
Cigarette Lighter.....	146
Sockets	147
Front Luggage Compartment.....	148
Rear Luggage Compartment.....	150
Luggage Cover	150
Loading Information	151

Storage

WARNING

Unsecured, incorrectly secured or incorrectly positioned loads

An unsecured or incorrectly positioned load can slip out of place or endanger the vehicle occupants as a result of braking, direction changes or in accidents.

- ▷ Do not transport items of luggage or objects unsecured in the passenger compartment.
- ▷ Do not transport any heavy objects in open storage trays.
- ▷ Always keep the covers of the storage trays closed while driving. Do not exceed the maximum gross weight and the axle load. This information can be found under "Technical data" in this Owner's Manual: Please see chapter "WEIGHTS" on page 222.
- ▷ Adapt the tire pressure to the load. If you change the tire pressure, you must also update the setting for Tire Pressure Monitoring System. Information on tire pressures for partially and fully loaded vehicles can be found under "Technical data" in this Owner's Manual: Please see chapter "TIRE PRESSURE FOR COLD TIRES (68 °F/ 20 °C)" on page 221.

Storage options

There are various storage options available, depending on the vehicle equipment:

- In the doors
- In the center console
- Storage net in the passenger's footwell

NOTICE

Heavy and bulky objects can damage the storage net.

- ▷ Do not place any heavy and bulky objects in the storage net.
-
- Clothes hook on back of seat backrests (depending on vehicle equipment).
 - Glove box with pen holder
 - Storage tray in the armrest
 - Side storage trays with retractable covers behind the seats
 - Drinks holder/cupholder

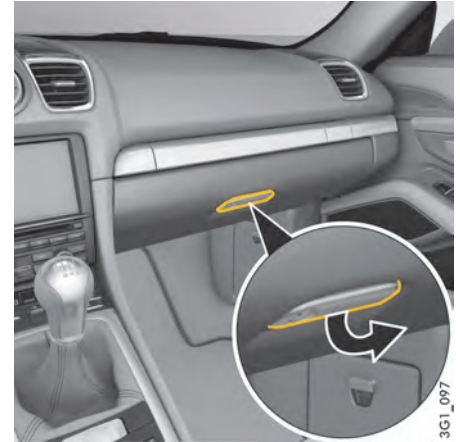

Glove box

On the inside of the glove box lid, there is a holder for clipping in a pen.

Opening

- ▷ Pull the latch handle (**arrow**) and open the lid.

Locking

- ▷ Always lock the latch handle with the emergency key to secure the contents from unauthorized access.



Storage tray in the armrest between the seats

Opening

- ▷ Press the button (**arrow**) on the passenger's side of the armrest.
The lid pops up automatically.

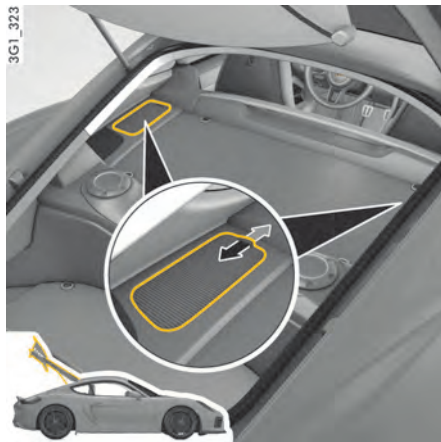

Side storage trays with retractable covers behind the seats

Opening

- ▷ Pull the handle of the retractable cover backwards in the direction of the arrow.

Closing

- ▷ Push the handle of the retractable cover forwards in the direction of the arrow.

Drinks Holder/Cupholder

You can place drinks in the cupholder.

CAUTION

Spilling hot drinks

Hot drinks can cause scalding if spilt.

- ▷ Only use containers that fit.
- ▷ Never put overfull containers in the cupholder.
- ▷ Do not use hot drinks.

NOTICE

Risk of damage due to drinks being spilt.

- ▷ Only use containers that fit.
- ▷ Never put overfull containers in the cupholder.

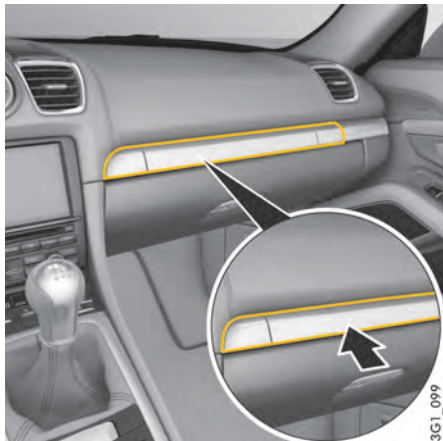

3C1_099

Opening the cupholder

There are two folding cupholders behind the panel above the glove box.

i Information

▷ Keep the closed when driving.

1. Press the cupholder panel.
The panel opens.

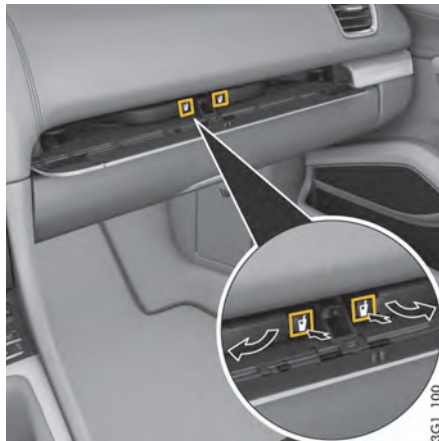

3C1_100

2. Press the symbol for the left or right cupholder.
The cupholder folds out.
3. Close the panel in the middle so that the cupholder does not move while driving.
The cupholders can be pulled out in order to fit larger containers.

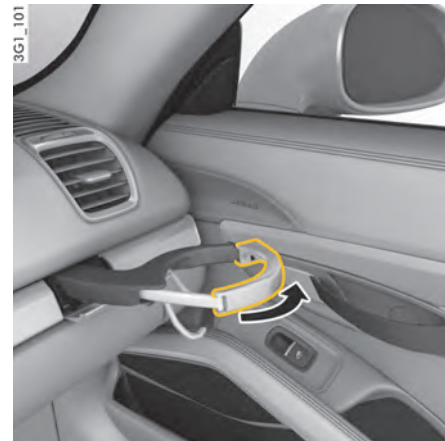

3C1_101

Pulling cupholder out

1. Pull out the holder (arrow).
2. Insert a cup/container.
3. Carefully slide the holder inwards to adjust it to the size of the cup/container.

Folding cupholder in

1. Push cupholder drawer in.
2. Open the panel in the middle.
3. Fold the cupholder in and engage it.
4. Close the panel in the middle.

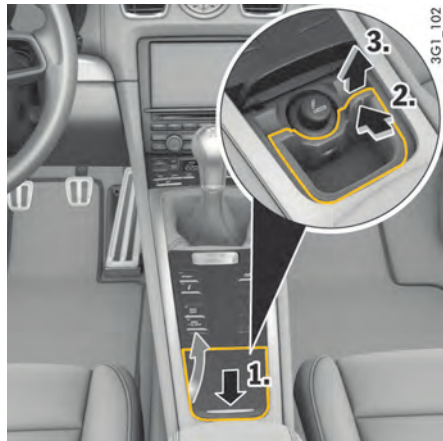

Ashtray

(depending on equipment)

⚠ WARNING

Ashtray fire risk

- ▷ Never use ashtray for waste paper disposal, as it could pose a fire hazard.

Opening

1. Press briefly on the ashtray lid.
The lid opens automatically.

Emptying

2. To unlock, press ashtray insert forwards at the top right until it is felt to disengage.
 3. Pull the ashtray insert upwards to remove it.
- ▷ After emptying the ashtray insert, replace it and push it downwards until it is felt to engage.

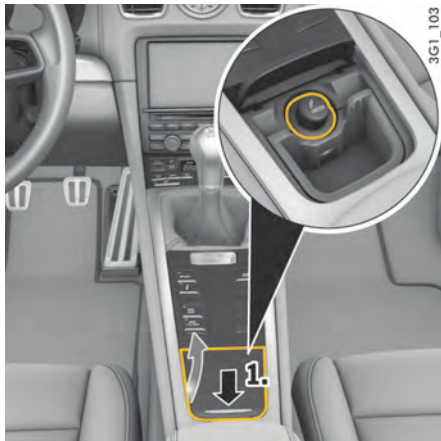

Cigarette Lighter

(depending on equipment)

⚠ WARNING

Burns due to hot cigarette lighter

The tip of the cigarette lighter becomes very hot in use.

- ▷ Do not leave children in the vehicle unattended.
- ▷ Never touch the heating element or sides of the lighter.
- ▷ Only hold the heated lighter by the knob.

Using the cigarette lighter

The cigarette lighter is ready for use regardless of ignition lock position.

- ▷ For information on using charging adapters in the cigarette lighter:

Please see chapter "USING CHARGING ADAPTER FOR 12 VOLT SOCKET/CIGARETTE LIGHTER" on page 147.

1. Press briefly on the ashtray lid.



2. Press the lighter into the receptacle. When the element is red hot, the lighter will jump back to its initial position

⚠ DANGER

Danger of fire due to the disposal of burning cigars or cigarettes

Cigarettes or cigars can be blown into the air inlets **A** by the air flow and cause a fire in the engine compartment.

- ▷ Do not throw burning cigarettes or cigars out of the vehicle.



Sockets in the glove box and passenger footwell

Sockets

Electrical accessories can be connected to the 12 V sockets. Depending on the vehicle equipment, these sockets are located in the glove box, the passenger footwell and in the oddments tray in the center console.

- ▷ For information on using charging adapters in 12 volt sockets: Please see chapter “USING CHARGING ADAPTER FOR 12 VOLT SOCKET/CIGARETTE LIGHTER” on page 147.

i Information

The maximum electrical load of a socket is 20 A, but only if no other loads are switched on. Do not exceed 10 A per socket if several loads are operating simultaneously.



Center console socket

i Information

The sockets and thus the connected electrical accessories function even if the ignition is switched off or the ignition key is removed. If the engine is not running and the accessories are switched on, the vehicle battery will be discharged. The power supply is interrupted after 30 minutes to protect the vehicle battery. If the load is to be switched on again, the ignition must be switched on once.

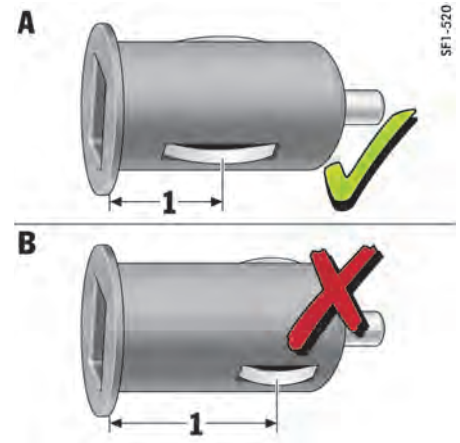

- A - Suitable charging adapter
- B - Unsuitable charging adapter

Using charging adapter for 12 volt socket/cigarette lighter

NOTICE

Risk of damage to the electrical system.

- ▷ Only use a suitable charging adapter (A) that meets the following requirements: The distance **1** between the ground connection and the upper edge of the charging adapter must be **less than** approx. 0.63 in. (16 mm).

Unsuitable charging adapters (B) with a larger distance **1** than 0.63 in. (16 mm) between the ground connection and the upper edge can destroy the sockets.

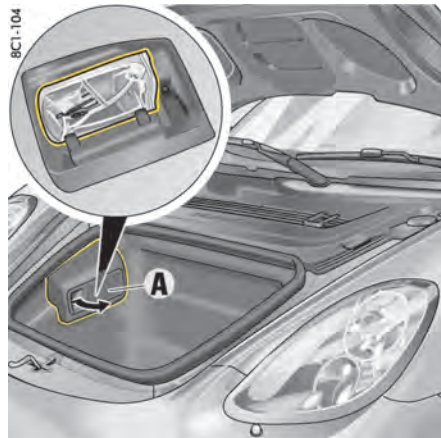

Front Luggage Compartment

- ▷ Please see chapter "OPENING AND CLOSING LUGGAGE COMPARTMENT LIDS" on page 24.

Tire sealant

The tire sealant is located in plastic box **A**.

- ▷ Grasp plastic box **A** at the handle recess and remove.
- ▷ To insert the plastic box, first insert the tab at the rear.
Engage the box at the front.

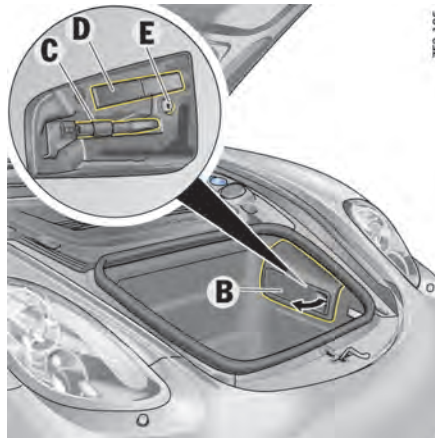

- C** - Towing lug
- D** - Tool kit
- E** - Adapter for security wheel bolts

Tools

The tools are located in a plastic box **B**.

- ▷ Grasp plastic box **B** at the handle recess and remove.
- ▷ To insert the plastic box, first insert the tab at the rear.
Engage the box at the front.

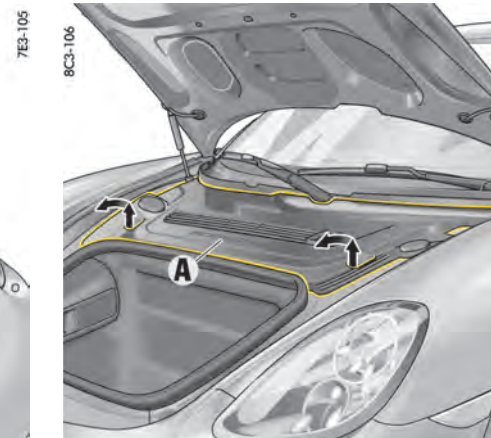

Tire filling compressor

Removing the tire filling compressor

1. Lift plastic cover **A** at the handle recesses (arrows) until the clips are heard to disengage and pull forwards slightly.
2. Lift the plastic cover at front.

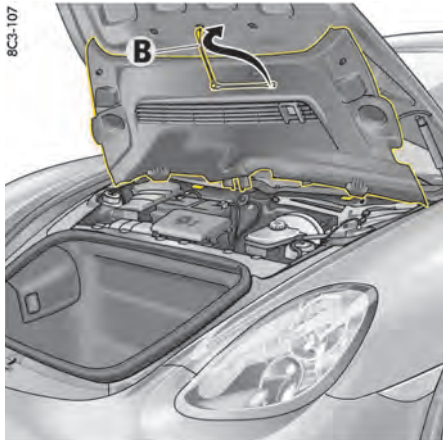

3. retaining strap **B** on the underside of the plastic cover and attach to the luggage compartment lid.

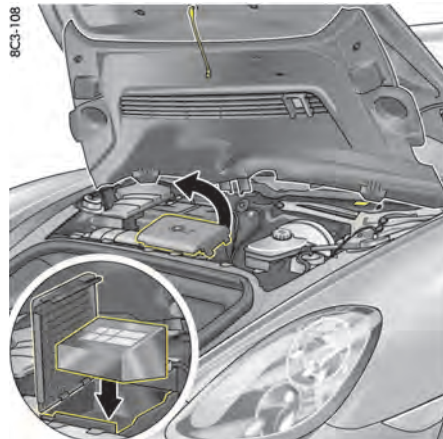

4. Open the cover of the storage compartment for the tire filling compressor.
5. Remove the tire filling compressor from the storage compartment.

Stowing the tire filling compressor

1. The tire filling compressor is wedge-shaped. Insert the tire filling compressor in the storage compartment so that the narrower side faces forwards (**illustration**).
2. Close the cover of the storage compartment for the tire filling compressor.

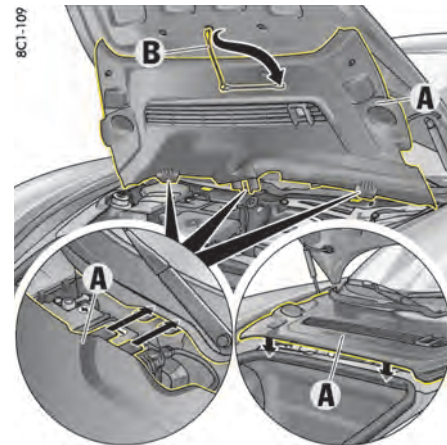

3. Detach retaining strap **B** and clip onto the plastic cover.
4. Insert plastic cover **A** with the guides at the rear edge and lay it on the yellow holder. Lower the plastic cover at the front.
5. Ensure that the centring pins on the underside of the cover engage in the guide. Press the cover downwards at the handle recesses, until the clips are heard to engage.

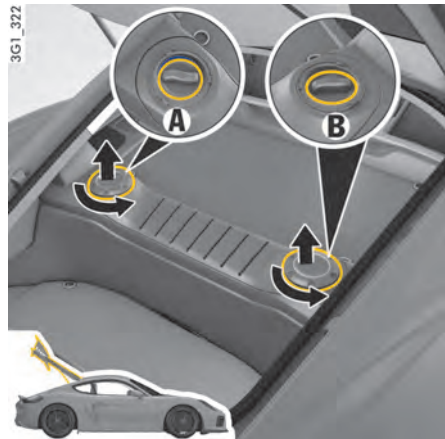

- A - Topping up coolant
- B - Topping up engine oil

Rear Luggage Compartment

The refilling points for coolant **A** and engine oil **B** are located in the rear luggage compartment.

- ▷ Please see chapter “CHECKING THE COOLANT LEVEL AND ADDING COOLANT” on page 184.
- ▷ Please see chapter “TOPPING UP ENGINE OIL” on page 166.

Luggage Cover

The luggage cover protects luggage in the rear storage area from direct sunlight and curious eyes.

NOTICE

Risk of damage to luggage cover from sharp-edged or sliding pieces of luggage.

- ▷ Always remove luggage cover if pieces of luggage might damage the luggage cover.

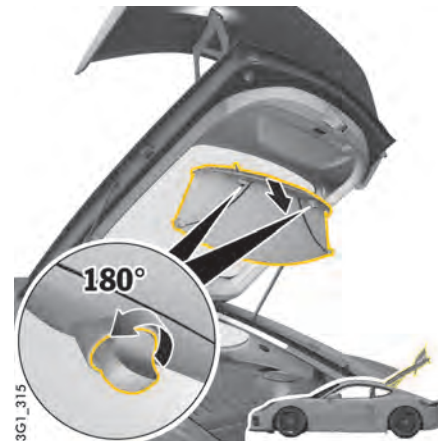

Removing the luggage cover

1. Hold luggage cover with one hand and loosen both turn-locks.
2. Remove the luggage cover using both hands.

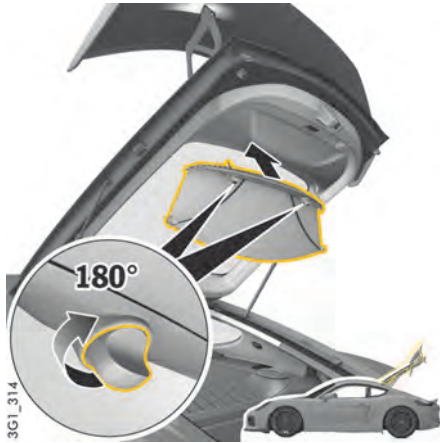

Installing the luggage cover

- ▷ Place luggage cover into the mounting with both hands, hold it with one hand and lock both turn-locks.

Loading Information

Definitions

The rear-axle load is the vehicle weight on the rear axle plus the weight of the transported load.

The Curb weight – actual weight of your vehicle - vehicle weight including standard and optional equipment, fluids, and emergency tools. This weight does not include passengers and cargo.

The Gross Vehicle Weight is the sum of the curb weight and the weight of passengers and cargo combined.

The Gross Vehicle Weight Rating is the maximum total weight of vehicle, passengers, luggage and optional equipment.

The Gross Axle Weight Rating is the maximum load limit for the front or the rear axle. This information is located on the safety compliance sticker located in the driver's side door aperture area.

For determining the compatibility of the tire and vehicle load capabilities:

- ▷ Please see chapter "TIRES AND WHEELS" on page 186.

The load capacity coefficient (e.g. "106") is a minimum requirement. For more information:

- ▷ Please see chapter "INSCRIPTION ON RADIAL TIRE" on page 194.

The Gross Combined Weight Rating is the maximum total weight rating of vehicle, passengers and cargo.

The Vehicle Capacity Weight – Load Limit - is the maximum total weight limit specified of the load (passengers and cargo) for the vehicle. This is the maximum weight of passengers and cargo that can be loaded into the vehicle. This information can be found on the tire pressure plate.

The maximum loaded vehicle weight is the sum of curb weight, accessory weight, vehicle capacity weight and production options weight.

The load rating is the maximum load that a tire is rated to carry for a given inflation pressure.

The maximum load rating is the load rating for a tire at the maximum permissible inflation pressure.

The cargo capacity is the permissible weight of cargo, the subtracted weight of passengers from the load limit.

⚠ DANGER

Overloading vehicle

Overloading will lead to dangerous vehicle reactions and long braking distances.

- ▷ Never exceed the specified axle loads.

NOTICE

Risk of damage to the vehicle if the vehicle is overloaded.

Overloading can shorten the service life of the tires and car. Damage due to overloading is not covered by the vehicle warranty.

- ▷ Never exceed the specified axle loads.

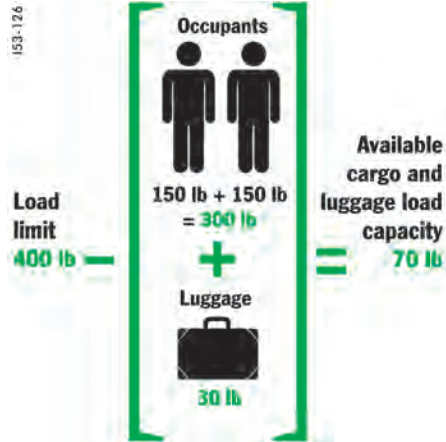

Example for determining the combined weight of occupants and cargo

Vehicle Load Capacity

- ▷ The combined weight of occupants and cargo should never exceed the weight shown on the tire pressure plate in the vehicle. Please see chapter "TIRE PRESSURE PLATE" on page 189.
- ▷ Never exceed the number of passengers shown on the tire pressure plate in the vehicle.

Determining the combined weight of occupants and cargo:

- ▷ Add the weight of all occupants and then add the total luggage weight (**figure**).

Steps for determining correct load limit

1. Locate the statement "The combined weight of occupants and cargo should never exceed XXX pounds" on your vehicle's placard (depending on the date of manufacture).
2. Determine the combined weight of the driver and passengers that will be riding in your vehicle.
3. Subtract the combined weight of the driver and passengers from XXX kilograms or XXX pounds.
4. The resulting figure equals the available amount of cargo and luggage load capacity. For example, if the "XXX" amount equals 400 lbs. and there will be two - 150 lb passengers in your vehicle, the amount of available cargo and luggage load capacity is 100 lbs. [400 - 300 (2 x 150) = 100 lbs.].
5. Determine the combined weight of luggage and cargo being loaded on the vehicle. That weight may not safely exceed the available cargo and luggage load capacity calculated in Step 4.

Parking

Garage Door Opener HomeLink® (Universal Remote Control).....	154
---	-----



Garage Door Opener HomeLink® (Universal Remote Control)

With the HomeLink® of your Porsche, a wide range of remote-controlled equipment (e.g. garage door/gate to your property, security systems, house lights) can be activated from inside the vehicle.

The HomeLink® system replaces up to three different original remote controls. The signal for a remote control can be assigned to one of the three memory buttons I, II and III on the overhead operating console keypad. The respective equipment can then be operated using the programmed memory button.

Transmission of the signal is indicated by the indicator light in the button II.

i Information

- ▷ Please read the instructions for the original remote control.
- ▷ Information on the compatibility of your vehicle's HomeLink® system with the original remote control can be obtained from your authorized Porsche dealer, on the HomeLink® website (www.homelink.com) or by calling the free HomeLink® hotline (1-800-355-3515).

⚠ WARNING

Garage door opener use

When opening and closing the equipment being operated, parts of the body could become trapped or crushed.

- ▷ When using the garage door opener, make sure that no persons or animals are within the range of movement of the equipment that is being operated.
- ▷ Observe the safety notes for the original remote control.

i Information

- ▷ When the button is pressed, the transmitter unit sends the signal forward in direction of travel. Always align the vehicle with the receiver. Otherwise, range restrictions cannot be ruled out.
- ▷ Before selling the vehicle, delete the programmed signals for the garage door opener on the keypad.
- ▷ If the equipment cannot be operated after the initial programming, check whether the original remote control has fixed or changeable code. To find this out, read the instructions for the original remote control.

Operating the garage door opener

The ignition must be switched on.

- ▷ Press and hold the corresponding HomeLink[®] button on the overhead operating console keypad.

The indicator light **A** lights up during signal transmission.

Programing garage door opener: Deleting and storing signals

The HomeLink[®] system is programed on the overhead operating console and in direct proximity to the vehicle's radiator grille.

Preconditions

In order to delete programed signals and store garage door opener signals,

- the ignition must be switched on,
- the turn signals must be off **and**
- the engine must be off.

When using the garage door opener, the vehicle must be within the range of the receiver.



Deleting programed signals from the buttons

This process clears all of the HomeLink[®] programing. It is not possible to individually clear the programed buttons.

Do not repeat this process if you want to assign additional signals to the buttons.

- ▷ Keep the two outer buttons **I** and **III** on the overhead operating console keypad pressed for approx. 20 seconds until the indicator light **A** on button **II** starts to flash quickly.
- ▷ Release the buttons.

The HomeLink[®] buttons are cleared and can be reprogramed.

Assigning garage door opener signal to key with fixed code system

On the overhead operating console:

1. Switch on ignition.
2. The standard factory-set codes must be deleted before programing for the **first time**.
3. Press and hold the desired button on the overhead operating console keypad until the indicator light **A** on button **II** starts to flash slowly.

You now have 5 minutes to teach the button.

4. Stand in front of the vehicle with the **original remote control** of the system to be programed.

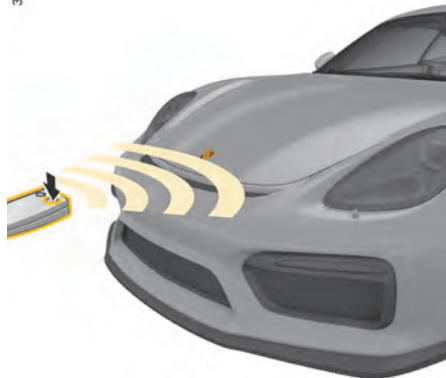

In front of the vehicle:

5. Hold the original remote control approx. 12 in. (30 cm) away from the marked position (**illustration**) and press and hold the **transmit button** (for more than approx. 1 minute in some cases) until the vehicle's turn signal lights flash on and off **three times** or the indicator light **A** on the overhead operating console starts flashing quickly. The turn signal lights flash three times and the indicator light **A** flashes quickly to confirm that the new signal has been programmed successfully. Several attempts with different distances between the vehicle and the original remote control may be necessary. With some systems, the transmit button on the original remote control may need to be pressed again when the indicator light on the original remote control goes out.

6. The turn signal lights will flash once when the 5 minute teaching readiness period has elapsed. Repeat steps 3 to 5.
7. Repeat steps 3 to 5 to assign further signals to the remaining buttons.

Assigning garage door opener signal to button with changeable code system

With some systems, a changeable code also needs to be programmed for the HomeLink® system. A second person makes programming easier.

Identifying the changeable code

- ▷ Press and hold the previously programmed HomeLink® button.

If the indicator light **A** on button **II** in the overhead operating console starts to flash quickly and lights up continuously after approx. 2 seconds, it means that the equipment has a changeable code system.

- ▷ Information on synchronization can also be found in the operating instructions for the system to be programmed.

Assigning garage door opener signal to key

- ▷ Park the vehicle within the range of the remote-controlled equipment.

On the overhead operating console:

1. Switch on ignition.
2. The standard factory-set codes must be deleted before programming for the **first** time.

For information on deleting the factory-set codes:

- ▷ Please see the chapter "PROGRAMMING GARAGE DOOR OPENER: DELETING AND STORING SIGNALS" on page 155.
3. Press and hold the desired button on the overhead operating console keypad until the indicator light **A** on button **II** starts to flash slowly. You now have 5 minutes to teach the button.
 4. Stand in front of the vehicle with the **original remote control** of the system to be programmed.

In front of the vehicle:

5. Hold the original remote control approx. 12 in. (30 cm) away from the marked position (**illustration**) and press and hold the **transmit button** (for more than approx. 1 minute in some cases) until the vehicle's turn signal lights flash on and off **three times** or the indicator light **A** on the overhead operating console starts flashing quickly. The turn signal lights flash three times and the indicator light **A** flashes quickly to confirm that the new signal has been programmed successfully. Several attempts with different distances between the vehicle and the original remote control may be necessary. With some systems, the transmit button on the original remote control may need to be pressed again when the indicator light on the original remote control goes out.

6. The turn signal lights will flash once when the 5 minute teaching readiness period has elapsed.
Repeat steps 3 to 5.
7. Repeat steps 3 to 5 to assign further signals to the remaining buttons.
8. Locate the programming button on the receiver of the equipment to be programmed, e.g. on the motor unit of the garage door opener.

Synchronizing the system

9. Activating the motor unit:

Press the programming button on the receiver of the garage door opener.
You then usually have approx. 30 seconds to initiate step 10 (a setting indicator is usually activated on the motor unit).

10. Programming on the overhead operating console:

Press the button you selected in step 3 three times on the overhead operating console keypad (you must press the button on the keypad several times to complete the setting process for some devices).

11. Repeat steps 3 to 10 to assign signals to the other buttons.
12. After completing programming on the overhead operating console, the system should recognize the HomeLink® signal and launch as soon as the memory button is pressed when the ignition is switched on.

Reprogramming an individual button on the keypad

A HomeLink® button can be individually reprogrammed without deleting the rest of the button assignments.

On the overhead operating console:

1. Switch on ignition.
2. Press and hold the button to be programmed on the overhead operating console keypad (approx. 20 seconds), until indicator light **A** on button **II** flashes slowly.
You now have 5 minutes to teach the button.
3. Stand in front of the vehicle with the **original remote control** of the system to be programmed.

In front of the vehicle:

4. Hold the original remote control approx. 12 in. (30 cm) away from the marked position (**illustration**) and press and hold the **transmit button** (for more than approx. 1 minute in some cases) until the vehicle's turn signal lights flash on and off **three times** or the indicator light **A** in the overhead operating console starts to flash quickly.
The turn signal lights flash three times and the indicator light **A** flashes quickly to confirm that the new signal has been programmed successfully.
Several attempts with different distances between the vehicle and the original remote control may be necessary.
With some systems, the transmit button on the original remote control may need to be pressed again when the indicator light on the original remote control goes out.

5. The turn signal lights will flash **once** when the 5-minute teaching readiness period has elapsed.
Repeat steps 1 to 4.
6. Repeat steps 1 to 4 to assign further signals to the other buttons.



Information

- ▷ Please consult an authorized Porsche dealer if you have not been able to successfully assign signals to the buttons even though you have carefully followed the instructions in this section and the operating instructions for the original remote control. Your authorized Porsche dealer has a list of all garage door opener signals that can be adapted.
- ▷ Make sure that the battery in the remote control for the garage door opener is new.
If the battery voltage is inadequate, faults may occur in signal transmission. The system in the vehicle then learns the wrong code, which will not be recognized reliably by the garage door opening mechanism.

Alarm System and Theft Protection

Alarm System and Passenger Compartment
Monitoring..... 159
Immobilizer 160
Theft Protection..... 160

Alarm System and Passenger Compartment Monitoring

FCC Numbers:

USA: KR55WK50138

Canada: 7812D-5WK50138

This device complies with Part 15 of the FCC Rules and RSS-210 of Industry Canada.

Operation of this device is subject to the following two conditions:

1. This device may not cause harmful interference, and
2. this device must accept any interference received including interference that may cause undesired operation.

Changes or modifications not expressly approved by the party responsible for compliance could void the user's authority to operate the equipment.



Information

The manufacturer is not responsible for any radio or TV interference caused by unauthorized modifications to this equipment.

Such modification could void the user's authority to operate the equipment.

The alarm system monitors the following alarm contacts:

- Alarm contacts in doors, luggage compartment lids and headlights.
- Interior surveillance: Movement in the interior when the vehicle is locked, e.g. attempted theft after breaking a window.
- Inclination sensor country-specific equipment: inclination of the vehicle (e.g. when attempting to tow).

If one of these alarm contacts is interrupted, the alarm horn sounds for approx. 30 seconds and the emergency flasher flashes. After 5 seconds of interruption, the alarm is triggered again. This cycle is repeated up to ten times.

Switching on

- ▷ The alarm system is activated when the vehicle is locked.

Switching off

- ▷ The alarm system is deactivated when the vehicle is unlocked.



Information

- ▷ If you unlock the vehicle with the emergency key in the door lock, you must switch the ignition on (ignition lock position **1**) within 10 seconds of opening the door in order to prevent the alarm system from being triggered.
-



Information

If button  on the vehicle key is pressed and a door or a luggage compartment lid is not opened, the vehicle is locked again automatically after 30 seconds.

Switching off the alarm system if it is triggered

- ▷ Unlock vehicle **or** switch on ignition.

Switching off interior surveillance and inclination sensor

If people or animals are remaining in the locked vehicle or the vehicle is being transported on, e.g. a train or ship, the interior surveillance system and inclination sensor must be switched off temporarily.

- ▷ Please see the chapter “LOCKING DOORS” on page 22.
- ▷ Inform any persons remaining in the vehicle that the alarm system will be triggered if the door is opened.

Using the vehicle key

- ▷ Quickly press button  on the vehicle key **twice** within 2 seconds. The emergency flasher flashes slowly once. The doors are locked, but can be opened from inside.



Information

The interior surveillance system and inclination sensor remain switched off if:

- The interior surveillance system and inclination sensor were switched off when you last locked the vehicle

and

If button **A**  was pressed and a door or a luggage compartment lid was not opened.

Function indication

The locking condition of the vehicle is indicated by the indicator lights in the central locking button flashing at different frequencies.

The indicator lights go out when the vehicle is unlocked.

The locking condition of the vehicle is indicated by the indicator lights in the doors flashing at different frequencies.

Alarm system is activated

- The indicator lights flash quickly twice when the vehicle is being locked, then flash normally.

Alarm system is activated, interior surveillance and inclination sensor are switched off

- The indicator lights flash quickly while you are locking the vehicle, go out for 10 seconds and then flash normally.

Faults in the central locking system and alarm system

The indicator lights come on for 10 seconds, flash at double speed for 20 seconds and then flash normally.

Avoiding false alarms

- ▷ If people or animals are remaining in the locked vehicle or the vehicle is being transported on a train or ship, for example, the interior surveillance system and inclination sensor must be switched off temporarily.
- ▷ Always close all door windows.

Immobilizer

There is a transponder (an electronic component), containing a stored code, in each key. Before the ignition is switched on, the ignition lock checks the code.

The immobilizer can be deactivated and the engine started using an authorized ignition key only.

Theft Protection

When leaving the vehicle, always:

- ▷ Close the windows.
- ▷ Activate the electric parking brake.
- ▷ Remove the ignition key
- ▷ Close the glove box.
- ▷ Close all storage compartments.
- ▷ Remove valuables, vehicle registration documents, telephone and house keys from the vehicle.
- ▷ Close the luggage compartment lids.
- ▷ Lock the doors.

Maintenance and Car Care

Exercise Extreme Caution when Working on your vehicle.....	162
Engine Oil.....	165
Checking Engine Oil Level.....	165
Topping up Engine Oil.....	166
Washer Fluid	167
Wiper Blades	168
Emission Control System.....	168
How Emission Control Works	169
Fuel Economy.....	170
Operating Your Porsche in other Countries.....	170
Fuel	171
Portable Fuel Container	173
Fuel Recommendations.....	173
Fuel Evaporation Control	174
Car Care Instructions.....	174

Exercise Extreme Caution when Working on your vehicle

The engine compartment of any motor vehicle is a potentially hazardous area. If you are not fully familiar with proper repair procedures, do not attempt the adjustments described on the following pages.

This caution applies to the entire vehicle.

DANGER

Fire and explosion hazards

Many vehicle fluids are highly flammable, e. g. fuel, engine and transmission oil. Fuel vapors can cause an explosion. When a battery is being charged, highly explosive gases can develop.

- ▷ Do not smoke or allow an open flame around the battery or fuel.
Pay attention to sparks, e. g. when coming into contact with cables.
Keep a fire extinguisher close at hand.
- ▷ Ensure that there are no open flames in the area of your vehicle at any time when fuel fumes might be present. Be especially cautious of devices such as hot water heaters which ignite a flame intermittently.
- ▷ Only work on your vehicle outdoors or in a well ventilated area.

WARNING

Fluid health hazards

Refill fluids, e. g. engine oil, brake fluid or coolant are hazardous to health (poisonous, irritant, caustic).

- ▷ Keep these fluids out of children's reach and dispose of them in accordance with the appropriate State, Local and Federal regulations.
- ▷ Only work on your vehicle outdoors or in a well ventilated area.

WARNING

Exhaust gas inhalation

Engine exhaust is dangerous if inhaled. Engine exhaust fumes have many components which you can smell. They also contain carbon monoxide (CO), which is a colorless and odorless gas. Carbon monoxide can cause unconsciousness and even death if inhaled.

- ▷ Only work on your vehicle outdoors or in a well ventilated area.

WARNING

Hot engine parts, exhaust system and fluids

The engine and surrounding components, exhaust system and coolant become very hot when the engine is running.

- The coolant reservoir is pressurized. Careless opening of the coolant reservoir can lead to hot coolant suddenly spraying out.
- ▷ Take care when working near hot parts of the vehicle, in particular engine parts and parts of the exhaust system.
 - ▷ Before working in the engine compartment, always switch the engine off and let it cool sufficiently.

- ▷ Allow the engine to cool down before opening the cap of the coolant reservoir and protect your hands, arms and face from any possible escape of hot coolant.

WARNING

Moving engine parts

Take great care to ensure that hands, fingers, articles of clothing (e. g. ties, sleeves, etc.), necklaces or long hair cannot be caught up by the radiator fans, drive belt or other moving parts.

The radiator fans in the front of the vehicle may be operating or unexpectedly start operating when the engine is switched on.

- ▷ Exercise extreme care that parts of the body, articles of clothing or jewelry do not get caught in the radiator fan, drive belt or other moving parts.
- ▷ Carry out work in these areas only with the engine off and exercise extreme caution.

WARNING

Electric shock from ignition system

When the ignition is on, all cables and wires of the ignition system carry a high voltage.

- ▷ Exercise special care when working on the ignition system.

⚠ WARNING

Failure to secure vehicle

If the vehicle is not secured, or incorrectly secured, during repair work, it could move unexpectedly or fall from the car jack or car lift.

- ▷ Be alert and cautious around the engine at all times while it is running.

If you have to work on the engine while it is running, always apply the electric parking brake.

- ▷ Always support your car with safety stands if it is necessary to work under the car. The jack supplied with the car is not adequate for this purpose.

Switch off level control of air suspension and height adjustment.

Please see the chapter "RAISING THE VEHICLE WITH A LIFTING PLATFORM, TROLLEY JACK OR STANDARD JACK" on page 195.

- ▷ Jack up the vehicle only at the specified jacking points on the underside of the vehicle.
 - ▷ Never start the engine when the vehicle is jacked or lifted up. Vibration from the engine could cause the vehicle to fall.
 - ▷ When working under the car without safety stands but with the wheels on the ground, make sure the car is on level ground, the wheels are blocked, and that the engine cannot be started. Withdraw ignition keys.
-

**Information**

- ▷ Incomplete or improper servicing may cause problems in the operation of the car. If in doubt about any servicing, have it done by your authorized Porsche dealer.
Improper maintenance during the warranty period may affect your Porsche warranty coverage.
 - ▷ Some countries require additional tools and special spare parts to be carried in your vehicle. Please make enquiries before driving abroad.
-

Technical Modifications

- ▷ Modifications may be carried out on your vehicle only if approved by Porsche. This ensures that your Porsche will remain reliable and safe to drive, and that it will not be damaged as a result of the modifications. Your authorized Porsche dealer will be pleased to advise you.

**Information**

- ▷ Only use genuine Porsche spare parts for your vehicle or spare parts of similar quality which have been manufactured according to the specifications and production requirements of Porsche. These parts are available from your authorized Porsche dealer. Safety-related accessories should only be used if they are from the Porsche Tequipment range or are tested and approved by Porsche. Your authorized Porsche dealer will be pleased to advise you and answer any questions you may have.

However, the use of other parts or accessories may adversely affect the safety of your vehicle, and Porsche can take no responsibility for any loss or damage caused by their use.

Even if the supplier of other accessories or parts is a recognized supplier, the safety of your vehicle may still be affected if such items are installed.

Due to the large variety of products offered in the accessory market, it is not possible for Porsche to inspect and approve every one.

- ▷ In addition, please note that the use of replacement parts that are not genuine Porsche parts or approved parts, or the use of accessories not approved by Porsche may also detrimentally affect your vehicle warranty.
 - ▷ Check your vehicle regularly for signs of damage. Damaged or missing aerodynamic components, such as spoilers or underbody panels, impair vehicle handling and must therefore be replaced immediately.
-

Radiator fan, engine compartment blowers

WARNING

Radiator fans, engine compartment blowers

The engine-compartment blowers are mounted in the engine compartment.

After the engine is switched off, the engine compartment temperature is monitored for approx. 30 minutes.

During this period, and depending on temperature, the engine-compartment blowers may continue to run or start to run.

- ▷ Carry out work in this area only with the engine off and exercise extreme caution.

The radiators and radiator fans are in the front of the vehicle.

The radiator fans in the front of the vehicle may be operating or unexpectedly start operating when the engine is switched on.

- ▷ Carry out work in these areas only with the engine switched off.
 - ▷ Take great care to ensure that parts of the body, items of clothing or jewellery cannot be drawn in by the radiator fan, engine-compartment blower, drive belt or other moving parts.
-

Measurements on test stands

Performance test

Performance tests on roller-type test stands are not approved by Porsche.

Brake tests

Brake tests must be performed only on roller-type test stands.

The following limit values must not be exceeded on roller-type test stands:

- Test speed 4.7 mph (7.5 km/h)
- Test duration 20 seconds

In order to fulfil legal stipulations, measurements with different limit values are permissible (e. g. exhaust emissions tests etc.).

Testing the electric parking brake

Electric parking brake tests on the brake test stand must only be performed with the ignition switched on and with the manual gearshift lever in neutral

The vehicle switches automatically to brake test stand mode, in which the electric parking brake can be tested.

The message “**Electric parking brake in service mode**” appears on the multi-function display in the instrument panel.

Balancing wheels on the vehicle

During finish balancing of the wheels, the entire vehicle must be lifted and the wheels must be free to turn.

Engine Oil

It is important to perform oil changes regularly in accordance with the intervals specified in your **Maintenance Schedule**.

Engine oil consumption

It is normal for your engine to consume oil. The rate of oil consumption depends on the quality and viscosity of oil, the speed at which the engine is operated, the climate, road conditions as well as the amount of dilution and oxidation of the lubricant.

If the vehicle is used for repeated short trips, and consumes a normal amount of oil, the engine oil measurement may not show any drop in the oil level at all, even after 600 miles (1000 km) or more. This is because the oil is gradually becoming diluted with fuel or moisture, making it appear that the oil level has not changed.

The diluting ingredients evaporate out when the vehicle is driven at high speeds, as on an expressway, making it then appear that oil is excessively consumed after driving at high speeds.

If the conditions you drive your vehicle in are dusty, humid, or hot, the frequency of the oil change intervals should be greater.

If the vehicle is driven at a high rate of speed, climatic conditions are warm, and the load is high, the oil should be checked more frequently, as driving conditions will determine the rate of oil consumption.

- The engine in your vehicle depends on oil to lubricate and cool all of its moving parts. Therefore, the engine oil should be checked regularly and kept at the required level.
- Make it a habit to have the engine oil level checked with every refueling.

- The oil pressure warning light is not an oil level indicator. The oil pressure warning light indicates serious engine damage may be occurring when lit, if engine rpm is above idle speed.

Checking Engine Oil Level

- ▷ Check the oil level on the multi-function display at regular intervals before refueling.
- ▷ Please see the chapter “DISPLAY AND MEASUREMENT OF THE ENGINE OIL LEVEL” on page 82.

DANGER

Swallowing engine oil

Engine oil is hazardous to your health and may be fatal if swallowed.

- ▷ Keep engine oil out of children's reach.

WARNING

Engine oil cancer risk

Used engine oil contains chemicals that have caused cancer in laboratory animals.

- ▷ Always protect your skin by washing thoroughly with soap and water.

If you suspect an oil leak in the engine have your authorized Porsche dealer check it out immediately.

Top-up quantity

The difference between the minimum and maximum marks on the segment display is approx. 1.8 quarts (1.7 liters).

- ▷ Never add more engine oil than required to reach the maximum mark.



Oil-level warning

If the oil level is too low, this is indicated by the oil-warning light on the multi-function display.

- ▷ Add engine oil immediately.
- ▷ Please see the chapter “OVERVIEW OF WARNING AND INFORMATION MESSAGES” on page 109.

Measuring the oil level after topping up engine oil or opening the rear luggage compartment lid

The oil level can be checked after waiting for approx. 1 minute with the vehicle parked on a level surface and the engine at operating temperature. If the rear luggage compartment lid is opened when the engine is cold (e.g. in order to top up engine oil), the oil level cannot be displayed for a certain time.

The message **“No information about oil level available at present”** appears on the multi-function display.

- ▷ Engine oil should therefore only be topped up with the engine at operating temperature. This ensures short waiting times for the soonest possible oil level display.



Information

The “Check Engine” warning light may come on if the cap of the oil filler opening is opened while the engine is running.

Topping up Engine Oil

Porsche recommends **Mobil 1**.

The right oil for your vehicle:

Complies with approval ¹⁾	Viscosity class ²⁾
Porsche A40	SAE 0W-40 ³⁾ SAE 5W-40 ⁴⁾ SAE 5W-50 ⁴⁾

¹⁾ Generally, you can find details of the manufacturer approvals on the oil containers or as a notice displayed by the retailer. The current approval status is also available from your authorized Porsche dealer.

²⁾ SAE viscosity class – Example: SAE 0W-40
Specification 0W = Viscosity specification for low temperatures (winter).
Specification 40 = Viscosity specification for high temperatures.

³⁾ For all temperature ranges.

⁴⁾ For the temperature range above –13 °F (–25 °C).

Always observe the following points:

- Use engine oils approved by Porsche only. This is a precondition for optimum and problem-free driving.
- Regular oil changes are part of servicing. It is important that the service intervals, particularly the oil change intervals, are observed in accordance with the specifications in the “Maintenance” booklet.
- Oils approved by Porsche can be mixed with each other.
- Porsche engines are designed so that no oil additives may be used.
- A label is located in the rear luggage compartment, which provides you with information on suitable oil for your engine.

Your authorized Porsche dealer will be pleased to advise you.

WARNING

Burning engine oil

Engine oil can ignite if it comes into contact with hot engine parts.

- ▷ Top up engine oil only with the engine stopped and ignition switched off.
 - ▷ Please see the chapter “EXERCISE EXTREME CAUTION WHEN WORKING ON YOUR VEHICLE” on page 162.
-

NOTICE

Risk of damage through overflowing engine oil. The luggage compartment or items of luggage may become soiled in this event.

- ▷ Take care not to soil the luggage compartment or items of luggage when checking and topping up engine oil.
-



1. Before opening the rear luggage compartment lid, read off the oil level on the multi-function display.
- ▷ Please see the chapter “DISPLAY AND MEASUREMENT OF THE ENGINE OIL LEVEL” on page 82.
2. Park the vehicle on a level surface.
3. Switch off engine (at operating temperature).
4. Open the rear lid.
5. Turn cap anti-clockwise and remove.
6. Unscrew cap on oil filler opening (**illustration**).
7. Top up engine oil according to the gauge on the multi-function display.
8. Carefully close cap on the oil filler opening.
9. Fit cap and turn it clockwise.
10. Close the rear lid.



Washer Fluid

Observe the following points:

- ▷ Depending on the season, mix the water with the appropriate additives (window cleaner concentrate, antifreeze) in the correct mixture ratio.

Summer filling with water + window cleaner concentrate in the mixture ratio specified on the container.

Winter filling with water + antifreeze + window cleaner concentrate in the mixture ratio specified on the container.

Always follow all the instructions on the containers of the additives used.

- ▷ Only use window cleaner concentrate that meets the following requirements:
 - Dilutability 1:100,
 - Phosphate-free,
 - Suitable for plastic headlight lenses.

We recommend window cleaner concentrates approved by Porsche. Your authorized Porsche dealer will be pleased to advise you.

The washer fluid reservoir for windshield and headlights is located in the front luggage compartment (**illustration**).



Warning message

A warning message appears on the multi-function display if the washer fluid level is too low.

- ▷ Add washer fluid at the next opportunity.

The maximum filling capacity is approx. 1.59 US gallons (6 liters).

Adding washer fluid

1. Open cap on washer fluid reservoir (**illustration**).
2. Add washer fluid.
3. Close cap carefully.

Wiper Blades

Maintenance notes

NOTICE

Risk of damage if wiper blades are not cleaned properly. The graphite coating on the wiper blades may be damaged.

- ▷ Do not clean the wiper blades using a cloth or sponge, but rinse with clean water.

NOTICE

Risk of damage due to unintentional folding back of wiper arm and frozen wiper blades.

- ▷ Always hold the wiper arm securely when replacing the wiper blade.
- ▷ Thaw the wiper blades before lifting them from the window.

Wiper blades that are in perfect condition are vital for a clear view.

- ▷ Have the wiper blades replaced twice per year (before and after the cold season) or if wiper performance deteriorates or the blades are damaged.
- ▷ After switching off the ignition, press the wiper stalk down once **4**.
The wipers move upwards by approx. 45°.
- ▷ Clean the windshield regularly with window cleaner, especially after washing the vehicle in a car wash.
We recommend Porsche window cleaner.
If they are very dirty (e.g. soiled with insect remains), they can be cleaned with a sponge or cloth.

If the wiper blades judder or squeak, this may be due to the following:

- If the vehicle is washed in an automatic car wash, wax residues may adhere to the

windshield. These wax residues can be removed only by using window cleaner concentrate.

- The wiper blades may be damaged or worn.
- ▷ Have damaged wiper blades replaced immediately.
- ▷ Please see the chapter “WASHER FLUID” on page 167.

Replacing wiper blades

- ▷ After switching off the ignition, press the wiper stalk down once.
The wipers move upwards to an angle of approx. 45°.
- ▷ Please read the separate instructions provided by the wiper blade manufacturer.
- ▷ We recommend that you get your authorized Porsche dealer to replace the wiper blades.

NOTICE

Risk of damage. If the wiper blades are not changed properly, they can come loose when the car is moving.

- ▷ Check that the wiper blades are seated securely.
The wiper blades must engage properly in the wiper arm.

Emission Control System

In the interest of clean air

Pollution of our environment has become a problem that is of increasing concern to all of us. We urge you to join us in our efforts for cleaner air in controlling the pollutants emitted from the automobile.

Porsche has developed an emission control system that controls or reduces those parts of emissions that can be harmful to our environment. Your Porsche is equipped with such a system. Porsche warrants the Emission Control System in your new car under the terms and conditions set forth in the Warranty Booklet.

You, as the owner of the vehicle, have the responsibility to provide regular maintenance service for the vehicle and to keep a record of all maintenance work performed. To facilitate record keeping, have services performed by authorized Porsche dealers. They have Porsche trained technicians and special tools to provide fast and efficient service.

To assure efficient operation of the Emission Control System:

- ▷ Have your vehicle maintained properly and in accordance with the recommendations described in your Maintenance Booklet. Lack of proper maintenance, as well as improper use of the vehicle, will impair the function of the emission control system and could lead to damage.
- ▷ Do not alter or remove any component of the emission control system.
- ▷ Do not alter or remove any device, such as heat shields, switches, ignition wires, valves, etc., which are designed to protect your vehicle's emission control system. In addition

to serious engine damage, this can result in a fire if excess raw fuel reaches the exhaust system.

- ▷ Do not continue to operate your vehicle if you detect engine misfire or other unusual operating conditions.

Parking

WARNING

Fire risk when parking

The exhaust system becomes very hot when the engine is running and remains hot for some time after the vehicle is turned off. Flammable material close to the exhaust system could ignite.

- ▷ Do not park or operate your vehicle in areas where the hot exhaust system may come in contact with dry grass, brush, fuel spill or other flammable materials.
- ▷ If your car catches on fire for any reason, call the fire department. Do not endanger your life by attempting to put out the fire.

Undercoating

WARNING

Aftermarket undercoating

Additional undercoating or rust protection agents on or near the exhaust system can become too hot when driving and ignite, causing a fire.

- ▷ Do not apply additional undercoating or rust protection agent on or near the exhaust manifolds, exhaust pipes, catalytic converters or heat shields. During driving the substance used for undercoating could overheat and ignite.

How Emission Control Works

When an automobile engine is running, it uses energy generated through the combustion of a mixture of air and fuel. Depending on whether a car is driven fast or slowly or whether the engine is cold or hot, some of the fuel (hydrocarbons) may not be burned completely, but may be discharged into the engine crankcase or exhaust system. Additional hydrocarbons may enter the atmosphere through evaporation of fuel from the fuel tank. These hydrocarbons (HC), when released into the air, contribute to undesirable pollution.

In addition, carbon monoxide (CO) and oxides of nitrogen (NOx) contribute to engine emissions. They, too, are formed during the combustion process and discharged into the exhaust system. To reduce these pollutants, your Porsche is equipped with a precisely calibrated fuel injection system to assure a finely balanced air/fuel mixture under all operating conditions.

Oxygen sensor

The oxygen sensor, installed in the exhaust pipe continuously senses the oxygen content of the exhaust and signals the information to an electronic control unit. The control unit corrects the air/fuel ratio, so the engine always receives an accurately metered air/fuel mixture.

Crankcase ventilation

Through crankcase ventilation, undesirable emissions from the engine crankcase are not permitted to reach the outside atmosphere. These emissions are recirculated from the crankcase to the air intake system. From here the emissions mix with the intake air and are later burned in the engine.

Catalytic converters

The catalytic converters are efficient “clean-up” devices built into the exhaust system of the vehicle. The catalytic converters burn the undesirable pollutants in the exhaust gas before it is released into the atmosphere.

The exclusive use of unleaded fuel is critically important for the life of the catalytic converters. Therefore, only unleaded fuel must be used.

The catalytic converters will be damaged by:

- Push or tow starting the vehicle,
- Misfiring of the engine,
- Turning off the ignition while the vehicle is moving,
- Driving until the fuel tank is completely empty,
- By other unusual operating conditions.
- ▷ Do not continue to operate your vehicle under these conditions, since raw fuel might reach the catalytic converters. This could result in

overheating of the converters. Federal law prohibits use of leaded fuel in this car.

Fuel Economy

Fuel economy will vary depending on where, when and how you drive, optional equipment installed, and the general condition of your car.

A car tuned to specifications and correctly maintained, will help you to achieve optimal fuel economy.

- ▷ Have your vehicle tuned to specifications. Air cleaner should be dirt free to allow proper engine “breathing”.
Battery should be fully charged.
Wheels should be properly aligned.
Tires should be inflated to the correct pressure.
- ▷ Always monitor your fuel consumption.
- ▷ Drive smoothly, avoid abrupt changes in speed as much as possible.
- ▷ Avoid jack rabbit starts and sudden stops.
- ▷ Do not drive longer than necessary in the lower gears. Shifting into a higher gear early without lugging the engine will help save fuel.
- ▷ Prolonged “warm up” idling wastes gas. Start the vehicle just before you are ready to drive. Accelerate slowly and smoothly.
- ▷ Switch off the engine if stationary for longer periods.
- ▷ Any additional weight carried in the vehicle reduces fuel economy. Always keep cargo to a minimum and remove all unnecessary items.
- ▷ Organize your trips to take in several errands in one trip.
- ▷ All electrical accessories contribute to increased fuel consumption.
- ▷ Only switch on the air conditioning when necessary.

The EPA estimated miles per gallon (mpg) is to be used for comparison purposes, actual mileage may be different from the estimated mpg, depending on your driving speed, weather conditions and trip length. Your actual highway mileage may be less than the estimated mpg.

- ▷ Please observe all local and national speed limits.

Operating Your Porsche in other Countries

Government regulations in the United States and Canada require that automobiles meet specific emission regulations and safety standards. Therefore, cars built for the U.S. and Canada differ from vehicles sold in other countries.

If you plan to take your Porsche outside the continental limits of the United States or Canada, there is the possibility that:

- Unleaded fuel may not be available,
- Unleaded fuel may have a considerably lower octane rating. Excessive engine knock and serious damage to both engine and catalytic converters could result,
- Service may be inadequate due to lack of proper service facilities, tools or diagnostic equipment,
- Replacement parts may not be available or very difficult to get.

Porsche cannot be responsible for the mechanical damage that could result because of inadequate fuel, service or parts availability.

If you purchased your Porsche abroad and want to bring it back home, be sure to find out about shipping and forwarding requirements, as well as current import and customs regulations.

Fuel

When the ignition is on, the fuel level is displayed on the instrument panel.

- ▷ Please see the chapter “J – FUEL GAUGE” on page 76.

DANGER

Refueling fire risk

- ▷ Fire, open flame and smoking are prohibited when handling fuel.

WARNING

Fuel vapors and skin contact

- Fuel and fuel vapors are hazardous to health.
- ▷ Avoid contact with skin or clothing, since injury to your skin may occur.
 - ▷ Do not inhale fuel vapors, since they may make you ill and possibly cause death if inhalation is prolonged and occurs in a closed space.

NOTICE

To prevent damage to the emission control system and engine:

- ▷ Never drive the tank dry.
 - ▷ Avoid high cornering speeds after the warning lights have come on.
- ▷ Please see the chapter “FUEL ECONOMY” on page 170.

Check engine warning light

If the warning lights in the instrument panel come on and remain on while driving, it suggests:

- a potential engine control problem and the need for system service **or**
- an improperly fastened tank cap **or** refueling with engine running.



Information

It is important that the service intervals, particularly the oil change intervals, are observed in accordance with the specifications in the “Maintenance” booklet.

Refueling

DANGER

Refueling fires / cellphones

The RF energy from a cellphone can cause a sparking on bare metal, much like aluminum foil in a microwave oven. The spark could ignite gasoline fumes present while refueling.

- ▷ Do not use a cellphone while pumping gas.

DANGER

Refueling fires / static electricity

Static discharge from your body can ignite gasoline fumes present when you get back out of the vehicle and touch the fuel nozzle.

- ▷ Do not re-enter the vehicle while pumping gas.



1. Stop the engine and switch off the ignition.
2. Open the filler flap by pressing on the rear part of the filler flap (**arrow**). The vehicle must be unlocked.

3G1_121

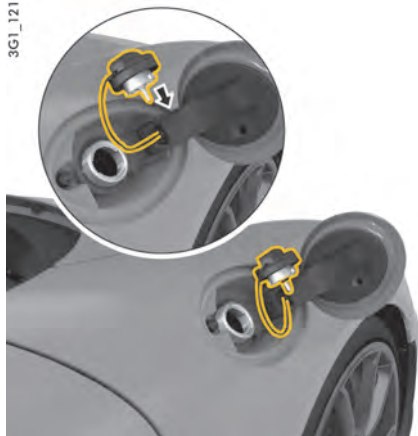

3. Slowly open and remove the tank cap. Put the tank cap into the holder (**arrow**).
4. Insert the pump nozzle fully into the filler neck. The handle of the pump nozzle must point downwards. The maximum filling capacity is approx. **14.27 US gallons** (54 litres) (optionally approx. **16.91 US gallons** (64 litres)), with a reserve of approx. 2.64 US gallons (10 litres).

5. Operate the pump nozzle and refuel the vehicle. Do not add further fuel once the correctly operated automatic pump nozzle has switched off. Fuel could spray back or could flow over when heated.
6. Replace the tank cap immediately after refueling and close it until you hear and feel it locking.
7. Close the filler flap and press on the rear of the filler flap until it engages securely.



Information

If you lose the tank filler cap, you must replace it only with an original part.

NOTICE

Risk of damage to decorative foils.
Decorative foils may fade if they come into contact with fuel.
▷ Wipe off any spilled fuel immediately.

BC1-122

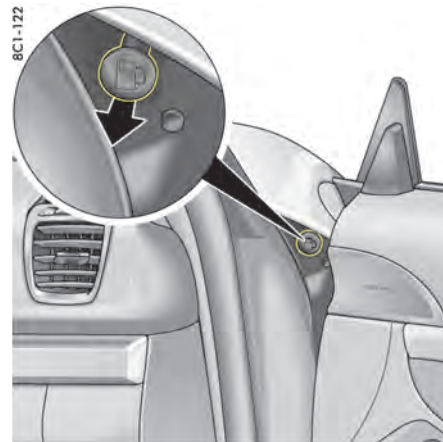

Emergency unlocking of the filler flap

If the electrical release mechanism is faulty, the filler flap can be opened as follows:

- ▷ Open the passenger's door.
- ▷ Pull the button in the right-hand door aperture (**arrow**).

The filler flap pops open.

Portable Fuel Container

DANGER

Transporting filled fuel containers

If the portable fuel container is damaged in an accident and fuel escapes, it could ignite or explode.

- ▷ Do not carry a portable fuel container on journeys.
- ▷ Observe the relevant laws which prohibit fuel transport.

WARNING

Portable fuel container vapor hazard

Vapors from the fuel are hazardous to health.

- ▷ Do not carry a portable fuel container in the occupant compartment.

Fuel Recommendations

Your Porsche is equipped with catalytic converters and must use **UNLEADED FUEL WITHOUT METALLIC ADDITIVES ONLY**.

Your engine is designed to provide optimum performance and fuel economy using unleaded premium fuel with an octane rating of **98 RON/88 MON (93 CLC or AKI)**. Porsche therefore recommends the use of these fuels in your vehicle.

Porsche also recognizes that these fuels may not always be available. Be assured that your vehicle will operate properly on unleaded premium fuels with octane numbers of at least **95 RON/85 MON (90 CLC or AKI)**, since the engine's "Electronic Octane™ knock control" will adapt the ignition timing, if necessary.

If fuels of less than **95 RON/85 MON (90 CLC or AKI)** are used however, this could reduce performance and increase fuel consumption.

- ▷ Avoid driving at full throttle.

It is important to observe the regular service intervals, and particularly the oil change intervals, specified in the "Maintenance" booklet.

The use of UNLEADED FUEL WITHOUT METALLIC ADDITIVES ONLY is critically important to the life of the catalytic converters. Deposits from leaded fuels or metallic additives will ruin the converters and make them ineffective as an emission control device. Metallic additives can cause serious engine damage.

Cars with catalytic converters have a smaller fuel tank opening, and gas station pumps that dispense unleaded fuel have smaller nozzles. This will prevent accidental pumping of leaded fuel into cars with catalytic converters.

Unleaded fuels may not be available outside the continental U.S. and Canada. Therefore, we recommend you do not take your car to areas or countries where unleaded fuel may not be available.



Information

In some countries the available fuel quality may not meet the requirements of your Porsche vehicle and can result in coking inside or around the injectorbores or other serious damage to the engine, fuel system or exhaust system.

In this case, the fuel may be mixed only with the additive sold and recommended by Porsche after consulting your authorized Porsche dealer.

Porsche part number 000 043 206 89.

- ▷ Observe the instructions and mixture ratios stated on the container.

It is important that the service intervals, particularly the oil change intervals, are observed

in accordance with the specifications in the "Maintenance" booklet.

NOTICE

Risk of destruction of the engine, fuel system or exhaust system if non-approved additives are used.

- ▷ Use only additives approved by Porsche. The use of other additives can result in destruction of the engine, fuel system or exhaust system of your vehicle.

Octane ratings

Octane rating indicates a fuel's ability to resist detonation. Therefore, buying the correct octane gas is important to prevent engine "damage". The RON octane rating is based on the research method. The CLC (U.S. **C**ost of **L**iving **C**ouncil octane rating) or AKI (**a**nti**k**nock **i**ndex) octane rating usually displayed on U.S. fuel pumps is calculated as research octane number plus motor octane number, divided by 2, that is written as:

$$\frac{\text{RON}+\text{MON}}{2} \quad \text{or} \quad \frac{\text{R}+\text{M}}{2}$$

The CLC or AKI octane rating is usually lower than the RON rating:

For example: 95 RON equals 90 CLC or AKI.

Fuels containing ethanol

Do not use any fuels containing more than 15 percent ethanol by volume.

We recommend, however, to change to a different fuel or station if any of the following problems occur with your vehicle:

- Deterioration of driveability and performance.
- Substantially reduced fuel economy.

- Vapor lock and non-start problems, especially at high altitude or at high temperature.
- Engine malfunction or stalling.

Fuel Evaporation Control

Fuel tank venting

The evaporation chamber and the carbon canister prevent fuel vapors from escaping to the atmosphere at extreme high outside temperatures, when driving abruptly around curves and when the car is parked at an incline or in any other nonlevel position.

Vapor control system and storage

When the fuel tank is filled, vapors are collected in the evaporation chamber by a vent line leading the vapors to the carbon canister where they are stored as long as the engine does not run.

Purge system

When the engine is running, the fuel vapors from the canister will be mixed with fresh air from the ambient air of the canister. This mixture will be directed to the intake air housing by the tank vent line, mixed with the intake air and burned during normal combustion.

Car Care Instructions

- ▷ Please see the chapter “MEASUREMENTS ON TEST STANDS” on page 164.

Regular Maintenance and correct care helps to maintain the value of your car and is also a requirement for maintaining the manufacturers vehicle warranties.

Your authorized Porsche dealer has specially developed car-care products from the Porsche program available either singly or as complete car-care sets. They will be pleased to help you select suitable products.

Whether you use Porsche products or other commercially available cleaning agents first make sure of their correct application.

A Porsche that is well-cared for can look like new for years. It all depends on the amount of care the owner is willing to give the car.

WARNING

Chemical cleaners

Cleaning agents may be hazardous to your health. Most chemical cleaners are concentrates which require dilution. High concentrations might cause problems ranging from irritation to serious injury.

- ▷ Keep cleaning agents out of reach from children.
- ▷ Observe all caution labels.
- ▷ Always read directions on the container before using any product. These directions may contain information necessary to avoid personal injury.
- ▷ Do not use fuel, kerosene, naphtha, nail polish remover or other volatile cleaning fluids. They may be toxic, flammable or hazardous in other ways. Only use spot removing fluids in a well vented area.
- ▷ Do not clean the underside of chassis, fenders, wheel covers, etc., without protecting your hands and arms as you may cut yourself on sharp-edged metal parts.

NOTICE

Risk of damage to the vehicle or property from cleaning agents.

- ▷ Observe all caution labels.



Information

Moisture and road salt on brakes may affect braking efficiency.

- ▷ Test the brakes after each vehicle washing.

High-pressure cleaning equipment, steam cleaners

NOTICE

Risk of damage as a result of using high-pressure cleaning equipment, steam cleaners or similar.

High-pressure cleaning equipment, steam cleaners or similar can damage the following components:

- Tires
 - Logos, emblems
 - Painted surfaces
 - Alternator
 - Electrical components and plug connections in the engine compartment
 - ▷ Always read the operating instructions provided by the equipment manufacturer.
 - ▷ Always cover the lid of the brake fluid reservoir prior to cleaning. Never point the cleaning jet directly at the lid.
 - ▷ When cleaning with a flat-jet nozzle or a so-called “dirt blaster”, maintain a minimum distance of 20 in. (50 cm).
 - ▷ Never use high-pressure cleaning equipment or steam cleaners with a round-jet nozzle. A high-pressure cleaning device or steam cleaner fitted with a round nozzle will damage your vehicle. The tires are particularly susceptible to damage.
 - ▷ Do not point the cleaning jet directly at any of the aforementioned components.
-

Decorative film

NOTICE

Risk of damage due to separation of the decorative film when using high-pressure cleaning equipment, steam cleaners or similar cleaning equipment.

- ▷ Do not use high-pressure cleaning equipment, steam cleaners, etc. to clean decorative films.
-

Care of door lock

- ▷ Never use excessive force.
- ▷ If the lock is frozen, use an ordinary de-icer.

Car washing

The best protection for the vehicle from the damaging effects of the environment is frequent washing and preservation.

The longer road salt, road dust, industrial dust, insect remains, bird excrement, and tree exudations (e.g. resin, pollen), etc. are allowed to remain on the bodywork, the more harmful their effect.

Observe the following points in order to ensure that the vehicle is washed thoroughly without damaging the paintwork:

- ▷ The underside of the vehicle should also be thoroughly washed at the end of the gritting season at the latest.
- ▷ Wash your vehicle only at sites provided for this purpose to prevent soot, grease, oil and heavy metals from entering the environment.
- ▷ New cars should be washed carefully with plenty of clear water to protect the new paint work. Dark paint finishes show up the smallest of surface damage (e.g., scratches) more readily than lighter colors. Dark colors are slightly more susceptible to scratching and require particularly careful

paint care.

Dark paints make even the smallest surface blemishes (scratches) more conspicuous than lighter colors.

- ▷ Do not wash your Porsche in direct sunlight or when its body is hot.
- ▷ When washing by hand, use a car shampoo, plenty of water, and a soft sponge or washing brush. We recommend Porsche car shampoo.
- ▷ Start washing the vehicle by thoroughly wetting the paintwork and rinsing the heavy dirt off.
- ▷ After washing the vehicle, rinse it thoroughly with water and rub it dry with chamois-leather. Do not use the same chamois for rubbing dry as you use for cleaning the windshield and windows.

⚠ WARNING**Wet brakes**

Reduced or uneven braking action may be caused by wet brakes.

- ▷ After washing the vehicle, test the brakes and steering and briefly brake the disks dry. When doing so, make sure that vehicles traveling behind you are not affected.

Cleaning in car washes

Optional add-on parts or parts that project beyond the contours of the vehicle may be damaged by design features of car washes.

The following parts are particularly at risk:

- Windshield wipers and rear wiper (always switch them off – wiper stalk in position **0** – to prevent them wiping unintentionally in sensor operation).
- Exterior mirrors (always fold in).
- External antenna (always unscrew).
- Spoiler.
- Wheels (the wider the rim and the lower the tire height, the greater the risk of damage).
- High-gloss wheels (to prevent these from getting scratched, do not clean with the wheel-cleaning brushes of the car wash).
- ▷ Please consult the operator before using automatic car washes.
- ▷ All parts not reached by a car wash, such as door and lid seams or door sills, must be washed and polished by hand.

**Information**

Automatic car washes spray water at odd angles and high pressures, which are not seen in normal driving. Therefore, water can sometimes find its way into the passengers compartment during or shortly after the car wash.

Paint care

In order to protect the paint on your vehicle in the best possible way against mechanical and chemical damage, you should

- preserve it regularly,
- polish it if necessary,
- remove spots and stains, and
- repair damaged paintwork.
- ▷ Do not apply care products containing silicone to the windows.

**Information**

- ▷ Never rub a dusty vehicle with a dry cloth, because the grains of dirt will damage the paintwork.
- ▷ Do not treat matt-painted components with preservatives or polishes as these remove the matt effect.

Preservation

The paint surface becomes dull over time due to weathering.

- ▷ Preserve paint regularly.
- ▷ Apply paint preservative after washing the vehicle and polish it smooth to preserve the paintwork.

This keeps the paint shiny and elastic. Dirt is prevented from adhering to the paint surface and industrial dust is prevented from penetrating the paint.

Polishing

Only when the original shine can no longer be obtained using preservatives should paint polish be used to clean the paint.

We recommend Porsche paint polish.

Removing spots and stains

- ▷ Remove tar splatters, traces of oil, insects etc. as soon as possible using an insect remover, as they discolor the paint if left to work on it over time.
- ▷ Wash the treated areas carefully afterwards.

Repairing minor paint damage

- ▷ Have minor paint damage (cracks, scratches or stone damage) repaired immediately **before** corrosion begins. Please contact an authorized Porsche dealer.

If traces of corrosion have already formed, these must be thoroughly removed. An anti-corrosion primer must then be applied to these spots, followed by top-coat paint.

Paint data can be found on the vehicle data carrier.

- ▷ Please see the chapter “VEHICLE IDENTIFICATION NUMBER” on page 218.

Cleaning windows

- ▷ Clean all windows regularly, inside and out, with window cleaner. We recommend Porsche window cleaner.
- ▷ Do not use the same chamois for painted surfaces and for drying the windows. Preservative residues could reduce transparency.
- ▷ Remove insect residues with insect remover.



Information

The door windows have a water-repellent (hydrophobic) coating, which prevents soiling of the windows.

This coating is subject to natural wear and can be renewed.

- ▷ Please contact an authorized Porsche dealer.

Care of windshield wiper blades

Windshield wiper blades that are in perfect condition are vital for a clear view.

- ▷ Please see the chapter "WIPER BLADES" on page 168.

Repairing the underbody protection

The underside of your car is durably protected against chemical and mechanical influences. As it is not possible to exclude the risk of damage to this protective coating in day to day driving, it is advisable to have the underside of the car inspected at certain intervals - preferably before the start of winter and again in spring - and the undercoating restored as necessary.

Your authorized Porsche dealer is familiar with the bodyseal treatment procedures and has the necessary equipment for applying factory approved materials. We recommend that you entrust them with such work and inspections.

Unlike conventional spray oils, undercoating and rust-proofing compounds based on bitumen or wax do not attack the sound-proofing materials applied at the factory.



WARNING

Exhaust system fire risk

The exhaust system becomes very hot when the engine is running. Flammable material close to the exhaust system could ignite. Additional undercoating or rust protection agents on or near the exhaust system can become too hot when driving and ignite.

- ▷ Do not apply additional undercoating or rust-proofing on or near the exhaust manifold, exhaust pipes, catalytic converters or heat shields. During driving the substance used for undercoating could overheat and ignite.
- ▷ Before applying fresh underseal, carefully remove deposits or dirt and grease. Once it has dried, the new undercoating compound forms a tough protective coating which provides efficient rust-proofing of the floor panels and components.
- ▷ Always apply a fresh coating of suitable preservative to unprotect areas after cleaning the underside of the body, the transmission, the engine or carrying out repairs to underbody, engine or transmission components.

Effective rust-proofing is particularly important during the cold weather season. If your car is driven frequently in areas where salt has been spread on the roads, the whole engine compartment should be cleaned thoroughly after the winter to prevent salt from causing any lasting damage. A full underbody wash should also be performed at the same time.

Cleaning headlights, lights, interior and exterior plastic components, adhesive foils

Observe the following points:

- ▷ Use **only** clean water and a little dishwashing liquid or interior window cleaner to clean headlights, lights, plastic components and surfaces.
Use a soft sponge or a soft, lint-free cloth.



Information

An interior window cleaner can also be used to clean plastic surfaces (always read the cleaning instructions on the container).

We recommend Porsche interior window cleaner.

- ▷ Gently wipe the surface without applying too much pressure.
- ▷ Do not clean when dry.
- ▷ Never use other chemical cleaners or solvents.
- ▷ Rinse cleaned surfaces with clear water.

Alloy wheels

Metal particles (e.g. brass or copper in brake dust) must not remain too long on alloy wheels. Contact corrosion can cause pitting.



Information

Cleaners with an oxide-removing effect or wrong pH value, as are commonly used for other metals, as well as mechanical tools and products, will damage the oxide layer and are therefore unsuitable.

- ▷ **Use only cleaners for alloy wheels (pH value 9.5). Products with the wrong pH value can destroy the protective layer on the wheels.**
We recommend Porsche cleaner for alloy rims.
- ▷ If possible, wash the wheels every two weeks with a sponge or washing brush. If the wheels are exposed to road salt, grit or industrial dust, weekly cleaning is necessary.
- ▷ Every three months, after cleaning, grease the wheels with car wax or an acid-free grease (e.g. Vaseline).
Rub the grease in well with a soft cloth.
- ▷ Please see the chapter "CLEANING IN CAR WASHES" on page 176.



WARNING

Cleaning agents on brake disks

If cleaning agents (e.g. wheel cleaning agents) come into contact with the brake disks, the resulting film on the brake disks can impair braking performance.

- ▷ Make sure that no cleaning agent comes into contact with the brake disks.
- ▷ If cleaning agent has come into contact with the brake disks, clean the brake disks thoroughly with a strong jet of water.
- ▷ Paying attention to any road users behind you, dry the brake disks by applying the brakes.

Stainless steel tailpipes

Stainless steel tailpipes can discolor due to soiling, strong heat and combustion residues. The original shine can be achieved again using commercially available metal lustre paste or metal polish.

Cleaning door, roof, lid and window seals

NOTICE

The lubricant coating on the inner door seals may be damaged by unsuitable cleaning and care agents.

- ▷ Do not use any chemical cleaning agents or solvents.
- ▷ Do not use any preservative agents.

- ▷ Wash dirt (e.g. abrasion, dust, road salts) from all seals regularly using warm soapy water.
- ▷ If there is a risk of frost, protect the outer door seals and the lid and flap seals against freezing into place with a suitable care product.

Leather care

The natural surface markings of leather, e.g. creases, healed scars, insect sting marks, structural differences and slight variations in shade and grain add to the attractiveness of the high-quality natural leather product.

Observe the following care instructions:

NOTICE

The leather will be damaged by the use of unsuitable cleaning and care agents and by inappropriate treatment.

- ▷ Do not use caustic cleaners or hard cleaning objects!
 - ▷ Make sure that perforated leather does not get wet on its reverse side.
 - ▷ Remove water drops from the leather without delay.
-
- ▷ Clean all types of leather regularly to remove fine dust using a soft, damp, white woollen cloth or a commercially available microfibre cloth.
 - ▷ Remove heavy contamination (not water or moisture stains) with a leather cleaner. Always read the instructions for use given on the containers. We recommend Porsche leather care liquid.
 - ▷ Treat cleaned leather only with a leather care product. We recommend Porsche leather care liquid.

Seats with seat ventilation

Care instructions for water or moisture stains.

Rain water or moisture can stain the perforated leather.

Removing water and moisture stains

Preconditions:

- Seat heating and seat ventilation must be switched off.
- No direct sunlight.
- Do not use leather cleaners or care products to remove water and moisture stains.
- ▷ Blot the entire seat or backrest surface using a clean, absorbent sponge and distilled water. Make sure that the perforated leather does not get wet on its reverse side.
- ▷ Allow the seat covering to dry completely at room temperature out of direct sunlight. Do not dry the seat covering by switching on the seat heating and seat ventilation.
- ▷ Once dry, wipe the seat covering with a dry, lint-free cloth.

Cleaning carpet, floor mats

- ▷ Use a vacuum cleaner or a brush (not too soft) for cleaning.
- ▷ Heavy dirt and stains can be removed with a stain remover. We recommend Porsche stain remover.

To protect carpets, the Porsche range of accessories includes mats of the correct size and with the appropriate fastening.

⚠ WARNING

Obstructed pedals

Improperly secured floor mats can obstruct pedal travel.

- ▷ Always check the movement of the pedals before driving and make sure that they are not obstructed by a floor mat or any other object.
- ▷ Secure the floor mat to prevent it from sliding into positions that could interfere with the safe operation of your vehicle – do not lay them loosely in the vehicle. Your authorized Porsche dealer will be glad to offer you floor mats of correct size including a securing possibility.

Cleaning airbag covers

⚠ DANGER

Vehicle interior modifications

Incorrect modifications may damage the airbag system. The airbag may not deploy properly in the event of an accident.

- ▷ Do not make any modifications whatsoever to individual components, such as the padded covers on the steering wheel, the instrument panel, the underside of the instrument panel, front seats and door panels.
- ▷ Have your authorized Porsche dealer to clean these components.

Cleaning fabric linings

- ▷ Fabric linings on pillars, roofliner and sun blinds, etc. must be cleaned only using suitable cleaning agents or a suitable dry foam and a soft brush.

Alcantara® care

Do not use leather care products to clean Alcantara®. Alcantara® is a manufactured product. It is not genuine leather or suede.

For regular care, it is sufficient to clean the cover with a soft brush.

Strong abrasion or rubbing when cleaning will produce a lasting change to the surface.

Cleaning when lightly soiled

- ▷ Wet a soft cloth with water or a neutral soap solution and wipe off the dirt.

Cleaning when heavily soiled

- ▷ Wet a soft cloth with lukewarm water or thinned white spirit and dab the dirt from the outside in.

Cleaning the safety belts

- ▷ Use mild detergent to clean soiled belts.
- ▷ When drying, avoid direct sunlight.
- ▷ Only use suitable cleaning agents.
- ▷ Do not tint or bleach the belts.
The belt fabric could be weakened, thus affecting safety.

Storing your Porsche

If you intend to store your Porsche for a prolonged period, please consult your authorized Porsche dealer. The staff will be glad to advise you on the most suitable and necessary methods.

- ▷ Clean your vehicle thoroughly inside and outside.

The under carriage and chassis components should be free of dirt and salt deposits.

- ▷ Fill up the fuel tank.
- ▷ Change the oil and oil filter, and run the engine for several minutes.
- ▷ Increase the tire pressure to 50 psi/3.5 bar/350 kPa.

It is not recommended to lift the vehicle, due to the possibility of corrosion on shock absorber piston shafts.

The vehicle should be moved slightly, approximately every four weeks, to prevent flat spot on the tires.

Climate control

The air conditioning system should be in good working condition and fully charged.

Windshield/Headlight washer

- ▷ Check and correct antifreeze/cleaning solution level as necessary.

Electrical system

- ▷ Remove the battery from the vehicle and store it in a cool dry place, not on a cement floor.

When the battery is disconnected, the alarm system is deactivated.

- ▷ Recharge the battery every 3 months. If the battery remains in the vehicle with the cables connected, it is necessary to check, remove and recharge the battery every 2-3 weeks.

Do not fast charge the battery.

- ▷ Please see the chapter "BATTERY (12 VOLT)" on page 205.

Vehicle interior

The interior must be dry, especially in the area of the floor carpets. The use of drying agents (Silica-Gel) is recommended in vehicles with leather interior and in areas with high humidity. The recommended amount is 3 fabric bags of 1.1 lbs. (500 grams) each placed on the floor carpets. Windows, doors and lids must be closed. The air vents should be opened.

Minor Repairs

Exercise Extreme Caution when Working on your vehicle	182
Checking the Coolant Level and Adding Coolant	184
Brake Fluid	185
Electromechanical Power Steering	186
Changing Air Cleaner	186
Changing Particle Filters	186
Tires and Wheels	186
Changing Wheels	196
Wheel Attachment Faces	198
Wheel Bolts	199
Flat Tire.....	199
Electrical System	201
Battery (12 volt).....	205
External Power Supply, Emergency starting with jumper cables	207
Changing Car Key (Remote Control) Battery ..	209
Replacing bulbs	210
Headlights	210
Headlight Adjustment.....	213
Towing	214
Fire extinguisher	216

Exercise Extreme Caution when Working on your vehicle

The engine compartment of any motor vehicle is a potentially hazardous area. If you are not fully familiar with proper repair procedures, do not attempt the adjustments described on the following pages.

This caution applies to the entire vehicle.

DANGER

Fire and explosion hazards

Many vehicle fluids are highly flammable, e. g. fuel, engine and transmission oil. Fuel vapors can cause an explosion. When a battery is being charged, highly explosive gases can develop.

- ▷ Do not smoke or allow an open flame around the battery or fuel.
Pay attention to sparks, e. g. when coming into contact with cables.
Keep a fire extinguisher close at hand.
- ▷ Ensure that there are no open flames in the area of your vehicle at any time when fuel fumes might be present. Be especially cautious of devices such as hot water heaters which ignite a flame intermittently.
- ▷ Only work on your vehicle outdoors or in a well ventilated area.

WARNING

Fluid health hazards

Refill fluids, e. g. engine oil, brake fluid or coolant are hazardous to health (poisonous, irritant, caustic).

- ▷ Keep these fluids out of children's reach and dispose of them in accordance with the appropriate regulations.
- ▷ Only work on your vehicle outdoors or in a well ventilated area.

WARNING

Exhaust gas inhalation

Engine exhaust is dangerous if inhaled.

Engine exhaust fumes have many components which you can smell. They also contain carbon monoxide (CO), which is a colorless and odorless gas.

Carbon monoxide can cause unconsciousness and even death if inhaled.

- ▷ Only work on your vehicle outdoors or in a well ventilated area.

WARNING

Hot engine parts, exhaust system and fluids

The engine and surroundings components, the exhaust system and coolant become very hot when the engine is running.

The coolant reservoir is pressurized. Careless opening of the coolant reservoir can lead to hot coolant suddenly spraying out.

- ▷ Take care when working near hot parts of the vehicle, in particular engine parts and parts of the exhaust system.
- ▷ Before working in the engine compartment, always switch the engine off and let it cool sufficiently.

- ▷ Allow the engine to cool down before opening the cap of the coolant reservoir and protect your hands, arms and face from any possible escape of hot coolant.

WARNING

Moving engine parts

Take great care to ensure that hands, fingers, articles of clothing (e. g. ties, sleeves, etc.), necklaces or long hair cannot be caught up by the radiator fans, drive belt or other moving parts.

The radiator fans in the front of the vehicle may be operating or unexpectedly start operating when the engine is switched on.

- ▷ Exercise extreme care that parts of the body, articles of clothing or jewelry do not get caught in the radiator fan, drive belt or other moving parts.
- ▷ Carry out work in these areas only with the engine off and exercise extreme caution.

WARNING

Electric shock from ignition system

When the ignition is on, all cables and wires of the ignition system carry a high voltage.

- ▷ Exercise special care when working on the ignition system.

⚠ WARNING Failure to secure vehicle

If the vehicle is not secured, or incorrectly secured, during repair work, it could move unexpectedly or fall from the car jack or car lift.

- ▷ Be alert and cautious around the engine at all times while it is running.

If you have to work on the engine while it is running, always apply the electric parking brake.

- ▷ Always support your car with safety stands if it is necessary to work under the car. The jack supplied with the car is not adequate for this purpose.

Switch off level control of air suspension and height adjustment.

Please see the chapter “RAISING THE VEHICLE WITH A LIFTING PLATFORM, TROLLEY JACK OR STANDARD JACK” on page 195.

- ▷ Jack up the vehicle only at the specified jacking points on the underside of the vehicle.
- ▷ Never start the engine when the vehicle is jacked or lifted up. Vibration from the engine could cause the vehicle to fall.
- ▷ When working under the car without safety stands but with the wheels on the ground, make sure the car is on level ground, the wheels are blocked, and that the engine cannot be started. Withdraw ignition keys.

i Information

- ▷ Incomplete or improper servicing may cause problems in the operation of the car. If in doubt about any servicing, have it done by your authorized Porsche dealer.
Improper maintenance during the warranty period may affect your Porsche warranty coverage.
- ▷ Some countries require additional tools and special spare parts to be carried in your vehicle. Please make enquiries before driving abroad.

⚠ WARNING

Radiator fans, engine compartment blowers

The engine-compartment blowers are mounted in the engine compartment.

After the engine is switched off, the engine compartment temperature is monitored for approx. 30 minutes.

During this period, and depending on temperature, the engine-compartment blowers may continue to run or start to run.

- ▷ Carry out work in this area only with the engine off and exercise extreme caution.

The radiators and radiator fans are in the front of the vehicle.

The radiator fans in the front of the vehicle may be operating or unexpectedly start operating when the engine is switched on.

- ▷ Carry out work in these areas only with the engine switched off.
- ▷ Take great care to ensure that parts of the body, items of clothing or jewellery cannot be drawn in by the radiator fan, engine-compartment blower, drive belt or other moving parts.

Measurements on test stands

Performance test

Performance tests on roller-type test stands are not approved by Porsche.

Brake tests

Brake tests must be performed only on roller-type test stands.

The following limit values must not be exceeded on roller-type test stands:

- Test speed 4.7 mph (7.5 km/h)
- Test duration 20 seconds

Testing the electric parking brake

Electric parking brake tests on the brake test stand must only be performed with the ignition switched on and with the manual gearshift lever in neutral or the Porsche Doppelkupplung selector lever in position **N**.

The vehicle switches automatically to brake test stand mode, in which the electric parking brake can be tested.

The message “**Electric parking brake in service mode**” appears on the multi-function display in the instrument panel.

Balancing wheels on the vehicle

During finish balancing of the wheels, the entire vehicle must be lifted and the wheels must be free to turn.



i Information

The tools required for changing a wheel (e.g. jack, wheel bolt wrench, assembly aids) are not supplied as standard with the vehicle. Your authorized Porsche dealer will be pleased to advise you.

Checking the Coolant Level and Adding Coolant

The coolant provides year-round protection from corrosion and freezing down to -35°F (-37°C). Regular checking of the coolant level is part of servicing. The coolant level only needs to be checked when a warning message appears on the multi-function display in the instrument panel.

- ▷ Please see the chapter "OVERVIEW OF WARNING AND INFORMATION MESSAGES" on page 109.
- ▷ Use only antifreeze authorized by Porsche.

DANGER

Swallowing engine coolant

Coolant is hazardous to health. Coolant can be deadly to children or pets if consumed.

- ▷ Keep coolant out of children's reach.
- ▷ Also, keep coolant away from your pets. They can be attracted to it should there be a spill, or to used coolant left in an open container.

WARNING

Hot engine coolant

The coolant becomes very hot when the engine is running and can burn you.

The coolant reservoir is pressurized. Careless opening of the coolant reservoir can lead to hot coolant suddenly spraying out.

- ▷ Do not open the cap on the reservoir when the engine is hot.
- ▷ Allow the engine to cool down before opening the cap and protect your hands, arms and face from any possible escape of hot coolant.



C - Coolant level indicator

Checking the coolant level when a warning message appears on the multi-function display in the instrument panel:

1. Allow the engine to cool as far as possible.
2. Turn cap anti-clockwise and remove.
3. Cover the reservoir cap with a cloth. Open reservoir cap carefully and allow any overpressure to escape. Finally, unscrew reservoir cap completely.
4. Reading off the engine coolant level: When the **engine is cold** and the vehicle is level, the coolant level indicator **C** must be between MIN and MAX markings.
5. Top up with coolant if necessary. Only add a mixture of antifreeze and distilled water in equal parts.

Antifreeze in coolant:

50 % provides antifreeze protection down to -35°F (-37°C).

The maximum fill level is reached when the

coolant level indicator **C** is at the MAX marking. Do not exceed the MAX-mark when topping up.

6. Screw the cap on the reservoir closed until it locks securely.
7. Fit cap and turn it clockwise.
8. Have the cooling system checked. Please contact an authorized Porsche dealer.

Information

If pure water is added in an emergency, the mixing ratio will have to be corrected.

A significant loss of coolant indicates a leak in the cooling system.

- ▷ The cause must be eliminated without delay. Please contact an authorized Porsche dealer.

⚠ WARNING

Engine-compartment blowers or other moving parts in the area of the engine

Hands, fingers, items of clothing (ties, sleeves, etc.), necklaces or long hair can be drawn in by moving parts, e.g. the engine-compartment blowers, drive belt, etc., when working in the engine compartment.

The engine-compartment blowers are mounted in the engine compartment.

After the engine is switched off, the engine compartment temperature is monitored for approx. 30 minutes.

During this period, and depending on temperature, the engine-compartment blowers may continue to run or start to run.

- ▷ Carry out work in this area only with the engine off and exercise extreme caution.

⚠ WARNING

Hot engine parts

The engine and adjacent components become very hot when the engine is running.

- ▷ Exercise extreme caution when working in the engine compartment.

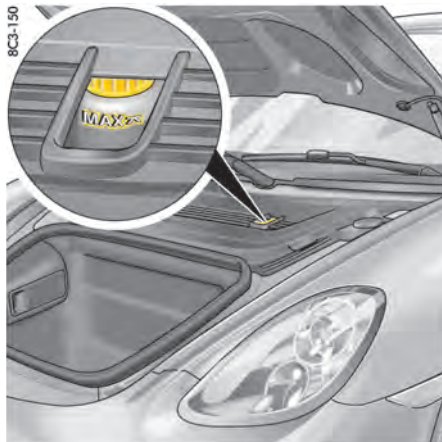
**Brake Fluid**

Regular checking of the brake fluid is part of servicing.

The fluid level should always be between the MIN and MAX markings.

A slight decrease in the fluid level due to wear and automatic readjustment of the disk brakes is normal.

However, if the fluid level falls significantly or goes below the MIN marking, the brake system may have developed a leak.

- ▷ Have the brake system checked immediately. Please contact an authorized Porsche dealer.

⚠ DANGER

Swallowing brake fluid

Brake fluid is hazardous to your health, and may be fatal if swallowed.

- ▷ Keep brake fluid out of children's reach.
- ▷ If brake fluid gets into your eye, immediately rinse with clean water for a few minutes. Then see a doctor immediately.
- ▷ Please note all the information on the refill container of the brake fluid.

NOTICE

Brake fluid attacks and can damage paintwork.

- ▷ Immediately rinse off spilled brake fluid with clean water.

Changing brake fluid

Brake fluid absorbs moisture from the air over time. The absorbed water can impair braking efficiency.

- ▷ It is important therefore to have the brake fluid changed in accordance with the change intervals specified in the "Maintenance" booklet.
- ▷ Use only brake fluid authorized by Porsche.

BRAKE Brake warning light USA**(!) Brake warning light Canada**

The warning light on the instrument panel and the warning message on the multi-function display alert you to the fact that the brake fluid level is too low and could indicate brake circuit failure if the pedal travel is greater than normal.

Information

If the warning light and warning message appear when driving:

- ▷ Stop immediately in a suitable place.
- ▷ Do not continue driving.
Please contact an authorized Porsche dealer.

For information on warning messages on the multi-function display:

- ▷ Please see the chapter “OVERVIEW OF WARNING AND INFORMATION MESSAGES” on page 109.

Electromechanical Power Steering

 **WARNING** No power steering assist

When the engine is stopped (e.g. when on tow), no power steering assistance is available. Increased force is required for steering.

- ▷ Exercise extreme care when your vehicle is being towed.
- ▷ Have the fault corrected. Please contact an authorized Porsche dealer.

Changing Air Cleaner

Regular replacement of the filter element is part of servicing.

- ▷ In dusty conditions, clean the filter element more frequently and replace it if necessary.
- ▷ Please see the chapter “MEASUREMENTS ON TEST STANDS” on page 183.

Changing Particle Filters

Regular replacement of the filters is part of servicing.

Dirty filters can be the cause of reduced air throughput, e.g. the windows can mist up.

- ▷ Have the filters replaced.
Please contact an authorized Porsche dealer.

Information

The particle filters ensure that the fresh air entering the passenger compartment is virtually free of dust and pollen.

- ▷ If the outside air is polluted by exhaust fumes, press the recirculated-air button.

Tires and Wheels

The original equipment tires and wheel rims on your Porsche comply with all applicable Federal Motor Vehicle Safety Standards.

Information

The summer tires of your car have been specially developed and adapted for high performance. At low outside temperatures (below 60 °F (15 °C)), the tire characteristics change. This can result in noises occurring when parking or maneuvering at low outside temperatures.

For your safety remember the following:

- Wheel rims and wheel bolts are matched to fit your Porsche.
- If you intend to use other than original equipment wheels, be sure that they conform to Porsche specifications for your model. Only tires with the same make and with the same specification code (e.g. “N0”, “N1”...) can be mounted.
- The use of wheel rims and wheel bolts that do not meet specifications of the original factory installed equipment will affect the safe operation of your vehicle and affect warranty coverage.
- Before you plan on exchanging wheels, or snow tires already mounted on the wheel rims, consult your authorized Porsche dealer. Your dealer has the technical information necessary to advise you which wheel rims and wheel bolts are compatible with the original factory installations.

⚠ DANGER

Tire damage while driving

Driving with damaged tires could cause you to lose control of the vehicle.

- ▷ If while driving, your vehicle experiences a sudden vibration or ride disturbance, and/or you suspect that possible damage to your tires or vehicle has occurred, you should immediately reduce your speed without excessive use of the brakes.
- ▷ Stop the vehicle as soon as possible, and inspect the tires.
If you cannot determine the cause for the disturbance, have your vehicle towed to the nearest Porsche or tire dealer to have your vehicle or tire(s) inspected.
- ▷ Continuing to operate the vehicle without correction could result in a loss of control.



Example

Uniform Tire Quality Grading

Quality grades can be found where applicable on the tire sidewall between tread shoulder and maximum section width.

All passenger car tires must conform to Federal Safety Requirements in addition to these grades.

Treadwear

The treadwear grade is a comparative rating based on the wear rate of the tire when tested under controlled conditions on a specific government test course. For example, a tire graded 150 would wear one and a half (1-1/2) times as well on the government course as a tire graded 100. The relative performance of tires depends upon the actual conditions of their use, however, and may depart significantly from the norm due to variations in driving habits, service practices and differences in road characteristics and climate.

Traction AA, A, B, C

The traction grades, from highest to lowest, are AA, A, B, and C and they represent the tire's ability to stop on wet pavement as measured under controlled conditions on specified government test surfaces of asphalt and concrete. A tire marked C may have poor traction performance.



Information

The traction grade assigned to this is based on braking (straight-ahead) traction tests and does not include cornering (turned) traction, acceleration, hydroplaning or peak traction characteristics.

Temperature A, B, C

The temperature grades are A (the highest), B and C, representing the tire's resistance to the generation of heat and its ability to dissipate heat when tested under controlled conditions on a specified indoor laboratory test wheel. Sustained high temperatures can cause the material of the tire to degenerate and reduce tire life, and excessive temperature can lead to sudden tire failure.

The grade C corresponds to a level of performance which all passenger car tires must meet under the Federal Motor Vehicle Safety Standard No. 109.

Grades B and A represent higher levels of performance on the laboratory test wheel than the minimum required by law.

⚠ WARNING**Tire abuse**

The temperature grade for this tire is established for a tire that is properly inflated and not overloaded. Excessive speed, underinflation, or excessive loading, either separately or in combination, can cause heat buildup and possible tire failure.

- ▷ Do not exceed the permitted maximum speed for the tires fitted to the vehicle.
- ▷ Ensure that the tires are set to the correct inflation pressure.
- ▷ Observe the maximum load for the vehicle.

Tire pressures**⚠ DANGER****Low tire pressure**

Driving the vehicle with low tire pressure increases risk of a tire failure and resulting loss of control. Furthermore, low tire pressure increases rate of wear of the affected tires and causes damage.

- ▷ Always use an accurate tire pressure gauge when checking inflation pressures.
- ▷ Do not exceed the maximum tire pressure listed on the tire sidewall. (Also refer to “Technical data”).
- ▷ Please see the chapter “TIRE PRESSURE PLATE” on page 189.
- ▷ Cold tire inflation pressure means: all tires must be cold, ambient temperature maximum 68 °F (20 °C), when adjusting the inflation pressure. Avoid sunlight striking the tires before measuring cold pressures, since the pressures would rise from temperature influence.
- ▷ Valve caps protect the valve from dust and dirt, and thus from leakage. Always screw caps tightly down. Replace missing caps immediately.

- ▷ Use only plastic valve caps.
- ▷ For safety reasons, don't use tire inflating bottles.

▷ Please see the chapter “TIRE PRESSURE FOR COLD TIRES (68 °F/ 20 °C)” on page 221.

Each tire, including the spare (if provided), should be checked monthly when cold and inflated to the inflation pressure recommended by the vehicle manufacturer on the vehicle placard or tire inflation pressure label. (If your vehicle has tires of a different size than the size indicated on the vehicle placard or tire inflation pressure label, you should determine the proper tire inflation pressure for those tires.)

As an added safety feature, your vehicle has been equipped with a tire pressure monitoring system (TPMS) that illuminates a low tire pressure telltale when one or more of your tires is significantly under-inflated. Accordingly, when the low tire pressure telltale illuminates, you should stop and check your tires as soon as possible, and inflate them to the proper pressure. Driving on a significantly under-inflated tire causes the tire to overheat and can lead to tire failure. Under-inflation also reduces fuel efficiency and tire tread life, and may affect the vehicle's handling and stopping ability.

Please note that the TPMS is not a substitute for proper tire maintenance, and it is the driver's responsibility to maintain correct tire pressure, even if under-inflation has not reached the level to trigger illumination of the TPMS low tire pressure tell-tale.

For further information on the tire pressure monitoring system:

- ▷ Please see the chapter “TIRE PRESSURE MENU (TIRE PRESSURE MONITORING SYSTEM, TPMS)” on page 86.

When tires are warm, the tire pressure is increased.

- ▷ Never let air out of hot tires. This could cause the tire pressure to fall below the prescribed value.

Insufficient tire pressure can cause tires to overheat and thus be damaged – even invisibly. Hidden tire damage is not eliminated by subsequently correcting the tire pressure.

Overloading**⚠ DANGER****Overloading tires**

Overloading can lead to dangerous vehicle reactions and long braking distances.

- ▷ Do not overload your vehicle.
- ▷ If you plan to load the vehicle, first correct the tire pressure. Tire pressure for loaded vehicle can be found on the tire pressure plate and in the chapter technical data.
- ▷ Never exceed the specified axle load.

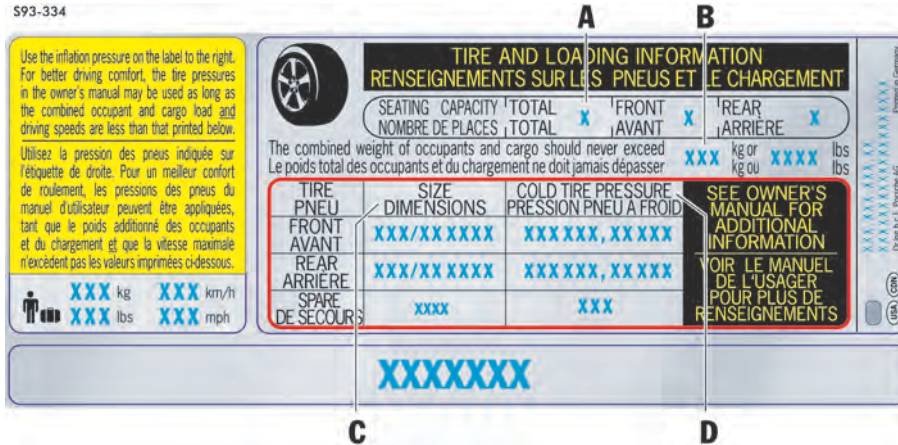

NOTICE

Risk of damage to the vehicle and to the tires.
Damage due to overloading is not covered by the vehicle warranty.

Tire damage may also be caused by overloading, and this damage is not covered by your tire warranty.

- ▷ Do not overload your vehicle.
 - ▷ If you plan to load the vehicle, first correct the tire pressure. Tire pressure for loaded vehicle can be found on the tire pressure plate and in the chapter “Technical data”.
 - ▷ Never exceed the specified axle load.
-
- ▷ Please see the chapter “LOADING INFORMATION” on page 151.

Example of a tire pressure plate

Tire Pressure plate

Information on the tire pressure plate

A Seating capacity

Maximum number of vehicle occupants, including the driver.

B Vehicle load limit

Is the maximum total weight limit specified of the load (passengers and cargo) for the vehicle. This is the maximum weight of passengers and cargo that can be loaded into the vehicle.

- ▷ Please see the chapter “LOADING INFORMATION” on page 151.

C Original tire size

Size of tires mounted at the factory.

D Recommended cold tire inflation pressure

These values are for cold tires (68 °F/20 °C).

Tire traction

⚠ WARNING Hydroplaning

When driving on wet or slushy roads, a wedge of water may build up between the tires and the road. This phenomenon is known as “hydroplane” and may cause partial or complete loss of traction, vehicle control or stopping ability.

- ▷ Reduce speed on wet surfaces.

Tire life

Tire life depends on various factors, i.e., road surfaces, traffic and weather conditions, driving habits, type of tires and tire care.

- ▷ Inspect your tires for wear and damage before driving off. If you notice uneven or substantial wear, wheels might need alignment or tires should be balanced or replaced.

Tire wear

The original equipment tires on your Porsche have built-in tire wear indicators. They are molded into the bottom of the tread grooves and will appear as approximately 1/2 in. (12 mm) bands when the tire tread depth is down to 1/16 of an in (1.6 mm).

When the indicators appear in two or more adjacent grooves, it is time to replace the tires. We recommend, however, that you do not let the tires wear down to this extent.

Worn tires cannot grip the road surface properly and are even less effective on wet roads.

In the United States, state laws may govern the minimum tread depth permissible. Follow all such laws.

DANGER

Excessively-worn tires

Driving on worn tires can result in loss of control of the vehicle and could cause serious personal injuries or death.

- ▷ Do not drive with worn tires or tires showing cuts or bruises as they may lead to sudden deflation and loss of control which could cause severe personal injury.

- ▷ Specialized high performance tires on high performance sports cars exhibit more wear than those on a family sedan, or even a high performance sedan.

Therefore, it is important to check your tire pressure and condition at least every two weeks.

- ▷ If you notice that tires are wearing unevenly, consult your authorized Porsche dealer.

Uneven wear may not always be due to improper wheel alignment. It can be the result of individual driving habits such as cornering at high speeds. If the tire pressure is not checked and adjusted regularly, abnormal tire wear can also occur.

Tire care

- ▷ Avoid damaging tires and wheel rims.
- ▷ If you must drive over a curb or other obstacle, drive slowly and at an obtuse angle.
- ▷ Check tires for uneven wear and damage before driving off.
- ▷ Remove embedded material.
- ▷ Replace worn or damaged tires immediately.
- ▷ Keep oil, fuel, brake fluid, etc. away from tires.
- ▷ Replace missing valve stem caps.
- ▷ Keep tires inflated correctly.
- ▷ Wash tires when washing the vehicle. Also clean inner side of wheels.
- ▷ Do not use abrasive cleaners when washing the wheels.
- ▷ Check wheel rims for corrosion.
- ▷ Remove road salt, if driving in winter.

Tire damage, puncture

- ▷ Please see the chapter “HIGH-PRESSURE CLEANING EQUIPMENT, STEAM CLEANERS” on page 175.

DANGER

Damaged tire check

Driving the vehicle with low tire pressure increases risk of a tire failure and resulting loss of control. Furthermore, low tire pressure increases the rate of wear of the affected tires.

- ▷ Check tires – including sidewalls – regularly for foreign bodies, nicks, cuts, cracks and bulges.
- ▷ After driving off road, examine tires for signs of damage such as cuts, tears, bulges or foreign objects stuck in the tread. Replace a damaged tire if necessary.
- ▷ Cross curb edges slowly and at right angles if possible. Avoid driving over steep or sharp curbs.
- ▷ In cases of doubt, have the wheel (particularly the inner side) checked by an authorized Porsche dealer.

In case of tire damage, where it is uncertain whether there is a break in the ply with all its consequences or tire damage caused by thermal or mechanical overloading due to loss of pressure or any other prior damage, we recommend that the tire be replaced for safety reasons.

If one faulty tire is replaced it should be noted that the difference in tread depth on one axle must not exceed 30 %. Handling inconsistencies may result.

- ▷ Recommendation: Replace both tires on one axle so that no handling inconsistencies may result due to different tread depths.
- ▷ Perform a visual inspection if necessary.

Tire replacements

- ▷ Use only tire makes and types tested by Porsche.

If you do not use a Porsche recommended replacement tire, make sure that you purchase your new tires from a reputable tire dealer and that the dealer complies with all manufacturers warnings for those tires.

Only tires with the same manufacturer and with the same specification code (e.g. "NO", "N1"...) should be mounted on the vehicle. Before mounting new tires, check with your Porsche dealer about the current release status.

Use tires with "ZR" quality standards. There are currently no standards concerning tire strength at speeds above 150 mph (240 km/h). Tires should be replaced no less than on one axle at the time. Only tires of the same make and type must be used. Mixed tires are not permissible and will affect vehicle performance, safety, and can affect vehicle warranty.

Authorized Porsche dealers can recommend the most current replacement tire options for your vehicle.

Initially, new tires do not have their full traction. You should therefore drive at moderate speeds during the first 60 - 120 miles (100 - 200 km).

Tires must always remain on the same side of the vehicle.

When wheels are removed, the direction of rotation and position of each wheel should be marked.

If new tires are installed only on **one** axle, a noticeable change in handling occurs due to the different tread depth of the other tires. This happens especially if only rear tires are replaced.

However, this condition disappears as the new tires are broken in.

- ▷ Please adjust your driving style accordingly. Installation of new tires should only be done by a qualified tire technician.

Valves

Please observe the fitting and replacement instructions:

- ▷ Only use genuine Porsche valves for the Tire Pressure Monitoring (TPM).
- ▷ Check the TPM valves whenever the tires are changed, and replace if necessary. We recommend that you get a Porsche partner to do this work as dealers have trained workshop personnel and the necessary parts and tools.
- ▷ Protect valve inserts from soiling using valve caps. Soiled valve inserts can cause a gradual loss of air.
- ▷ Use only plastic valve caps.

Parking at the curb



DANGER

Curb impact / tire damage

Hard impacts against curbs (or traffic islands) are dangerous and may cause hidden tire damage which is not noticeable until later. Such damage can result in accidents at high speeds. Depending on the force of impact, the edge of the rim can also be damaged.

- ▷ After such an impact, have the wheel checked by an expert.
- ▷ If you must drive over a curb or other obstacle, drive slowly and at an obtuse angle. Exercise care when parking along curbs.



Information

Tire repairs are not permissible under any circumstances.

Wheel alignment, wheel balancing

As a precaution, have wheels with summer tires balanced in the spring, and those with mud and snow tires before winter. Unbalanced wheels may affect car handling and tire life.

Only the specified weights may be used for wheel balancing.

Self-adhesive weights must not come into contact with cleaning agents, since they could drop off. Uneven tread wear indicates wheel imbalance. In this event, the vehicle should be checked at an authorized Porsche dealer.



DANGER

High-speed tire vibration

If, during a trip, uneven running or vibrations occur that could be caused by damage to tires or the car, the speed must be reduced immediately, but without braking sharply. If you continue your trip without having the cause of the fault remedied, you might lose control of your vehicle.

- ▷ Stop the vehicle and check the tires.
- ▷ If no cause for the fault can be found, drive carefully to the nearest authorized Porsche dealer.

Wheels with Tire Pressure Monitoring System (TPMS) sensors

Before changing wheels, make sure that the wheels are compatible with your vehicle's TPMS.

- ▷ Check this with your authorized Porsche dealer.

Removing and storing tires

- ▷ After changing, adjust tire pressure and torque wheel bolts diagonally.
Please see the chapter "CHANGING WHEELS" on page 196.
- ▷ Store tires in a cool and dry place. Rotate periodically to avoid flat spots.
- ▷ Do not store summer tires or park vehicles fitted with summer tires at ambient temperatures below 5 °F (-15 °C).
- ▷ Avoid contact with fuel, oil and grease.

Tires must always remain on the same side of the vehicle.

When wheels are removed, the direction of rotation and position of each wheel should be marked.

Example

FR (front right), FL, RR and RL.

Wheels must always be fitted in accordance with their marking.

The perception that tire durability and performance are not affected by storage and age is unfounded.

Chemical additives, which make the rubber elastic, lose their effectiveness over the course of time and the rubber becomes brittle and cracks.

Therefore, the tires should be inspected from time to time.



Information

Under no circumstances should tires older than 6 years be used on your Porsche.

The age of the tire can be obtained from the "DOT" code number. If, for example, the last four numbers read 1211, then the tire was produced in the 12th week of 2011.

Snow tires

The installation of Porsche approved snow tires is recommended.

Use Porsche approved snow tires for grip on snow and ice. Summer performance tires are not suitable for usage in cold, snowy, or icy conditions.

Check with your local Motor Vehicle Bureau for possible restrictions.



WARNING

Snow tire use

The standard tires profile and rubber mixture are optimized for wet and dry driving conditions, and may not prove favorable for snow conditions.

- ▷ Install snow tires before driving in such conditions.
-

NOTICE

Risk of insufficient road grip leading to loss of control and damage to the vehicle.

The standard tires profile and rubber mixture are optimized for wet and dry driving conditions, and may not prove favorable for snow conditions.

- ▷ Install snow tires before driving in such conditions.
-

Before mounting snow tires, consult with your Porsche dealer. They have the technical information necessary to advise you on wheel and tire compatibility.

- ▷ Snow tires should have the same load capacity as original equipment tires and should be mounted on all four wheels.



DANGER

Tire hazards

Driving the vehicle with low tire pressure increases risk of a tire failure and resulting loss of control. Furthermore, low tire pressure increases the rate of wear of the affected tires and causes damage. Tires with badly worn treads are very dangerous and could cause accidents.

- ▷ Make sure they are replaced immediately.
- ▷ Do not exceed the snow tire speed rating.

Snow tires do not have the same degree of traction on dry, wet or snowfree roads as normal tires.

Furthermore, snow tires wear rapidly under these conditions.



Information

We recommend that you fit snow tires on the vehicle at temperatures below 45 °F (7 °C) since the driving performance of summer tires is reduced at low temperatures and a lower level of comfort can also be expected. For example, juddering noises caused by the tires can occur while maneuvering the vehicle or accelerating out of bends on both dry and wet road surfaces.

Extremely low temperatures of below 5 °F (-15 °C) can cause permanent damage to summer tires.

Snow tires lose their suitability when their tread depth falls below 5/32 in. (4 mm).

Comply with all state and local laws governing snow tire and tread depth requirements.



Excessive speed for tires

Exceeding the maximum permitted speed for the tires fitted could cause tire failure.

- ▷ Always check the maximum speed rating on the tire sidewall on any tire on the vehicle.
 - ▷ Never exceed the maximum speed rating of the tires.
-

Wheel change

- ▷ When wheels are removed, mark the direction of rotation and position of each wheel. Example: FR (front right), FL, RR and RL.
- ▷ Always fit the wheels in accordance with the markings.

Snow chains

NOTICE

Risk of damage to body, axle or brake components.

- ▷ Fit snow chains only to the rear wheels, and only with the tire/rim combination listed in the Technical Data.
 - ▷ Use only the fine-link snow chains recommended and authorized by Porsche so that sufficient clearance between the wheel well and the chain is assured.
 - ▷ Please see the chapter "WHEELS, TIRES" on page 220.
 - ▷ Follow instructions issued by the supplier of the chains.
-

Fitting snow chains

Using snow chains is not permitted if 1/5 in. (5 mm) spacers are fitted.

- ▷ To permit the fitting of snow chains, have the 5 mm spacers removed on all 4 wheels.
- ▷ Before fitting chains, remove accumulated ice and snow from the wheel well.
- ▷ Vehicles with snow chains must not be driven faster than **30 mph (50 km/h)**.

Different states and countries have varying statutory requirements regarding maximum speed.

- ▷ Check with local authorities for possible restrictions.
 - ▷ Remove chains as soon as the roads are free of ice and snow.
 - ▷
-

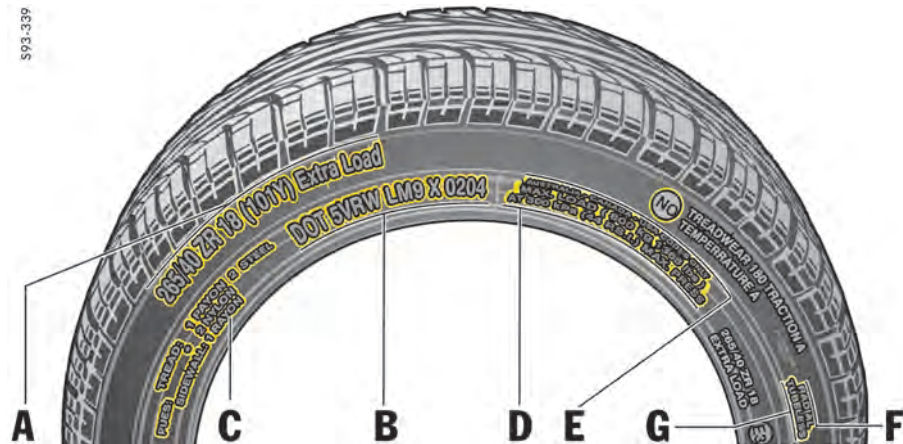

Example of Inscription

Inscription on radial tire

A – Tire size

Example: P 265/40ZR18 (101Y)

- **P** - The tire is designed for Passenger vehicle. This information is not included on all tires.
- **265** - Indication of tire width in mm
- **40** - Indication of tire height to tire width ratio in percent
- **ZR** - Belt type code letter for radial
- **18** - Indication of rim diameter in inches
- **101** - Load capacity coefficient

- **Y** - Speed code letter
- **XL (Extra Load)** - Tire with increased load rating

B – TIN (Tire Identification Number)

Example: DOT xx xx xxxx xxxx

- DOT
- The DOT symbol indicates that the tires comply with the requirements of the US Department of Transportation and provides information about:
 - first two-digit code means manufacture's identification mark.
 - second two-digit code means tire size.

- third four-digit code means tire type code.
- fourth four-digit code means date of manufacture.

If, for example, the last four numbers read 0211, the tire was produced in the 2nd week of 2011.

C – Tire ply composition and material

The number of layers in the tread and sidewalls and their material composition.

D – Maximum permissible inflation pressure

The maximum permissible cold inflation pressure to which a tire can be inflated.

- ▷ Do not exceed the permissible inflation pressure.

E – Maximum Load rating

The maximum load in kilograms and pounds can be carried by the tire. If you replace tires always use a tire that has the same maximum load rating as the factory installed tire.

F – Radial

The identification indicates if the tire has radial structure.

G – Term of tubeless or tube tire

Identification for tubeless tires.

Speed code letters

The speed code letter **Y** indicates the maximum permitted speed for the tire.

This code letter is shown on the tire sidewall.

- T** up to 118 mph (190 km/h)
- H** up to 131 mph (210 km/h)
- V** up to 150 mph (240 km/h)
- W** up to 165 mph (270 km/h)
- Y** up to 185 mph (300 km/h)
- (Y)** up to 185 mph (300 km/h) as for Y tires. Speeds of more than 185 mph (300 km/h) are also possible at a maximum tire load capacity of 85 % (confirmation from tire manufacturer required for speeds of more than 185 mph (300 km/h)).



Information

Tires with a maximum speed rating that is lower than the specified maximum vehicle speed may be mounted only if they bear an M+S identification on the tire sidewall.

- ▷ Please note that in addition to snow tires, all-season tires are also subject to speed limits and bear this identification.
- ▷ Never drive faster than the speed rating of the tires, and obey all speed and traffic laws.



- G** - Rim width in inches
- H** - Rim-flange contour code letter
- I** - Symbol for drop-center rim
- J** - Rim diameter in inches
- K** - Double hump
- L** - Rim offset in mm

Inscription on alloy wheels

The information is provided on the rear of the spokes. The rim width in inches **A** and the rim offset **F** are visible from the outside. This information can be found near the tire valve.

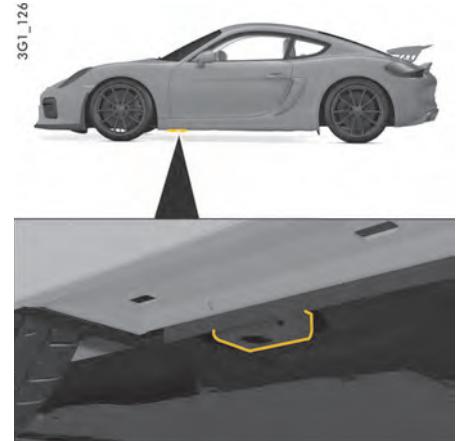

Jacking point for lifting platform and jack at the front

Raising the vehicle with a lifting platform, trolley jack or standard jack

- ▷ Before driving the vehicle onto a lifting platform, make sure that there is sufficient space between the lifting platform and the vehicle.



Jacking point for lifting platform and jack at the rear

NOTICE

Risk of serious damage to the engine or vehicle if you lift the vehicle improperly.

- ▷ Lift only at the jacking points provided.
- ▷ Before driving the vehicle onto a lifting platform, make sure that there is sufficient space between the lifting platform and the vehicle.
- ▷ To avoid serious damage, never jack up the vehicle at the engine, transmission or at the axles.
- ▷ Use only level anti-slip rubber pads on a lifting platform.
- ▷ Do not damage any sensitive components in the vicinity of the jacking points.

Changing Wheels



DANGER

Unsafe stopping

Other vehicles could collide with your vehicle if you are parked in a dangerous position.

- ▷ If you have a flat tire, move a safe distance off the road. Turn the emergency flasher on and use other warning devices to alert other motorists.
- ▷ Do not remain in the car. Someone approaching from the rear may not realize your vehicle is stopped and cause a collision.



WARNING

Stopping over nearby flammable matter

Exhaust fumes and the exhaust system are very hot when the engine is running. The exhaust system remains hot for some time after the vehicle is turned off.

- ▷ Do not park your vehicle in areas where the hot exhaust system may come in contact with dry grass, brush, fuel spill or other flammable material.



WARNING

Jacking risks

If the vehicle is not secured, or incorrectly secured, during a wheel change, it could move unexpectedly or fall from the car jack.

- ▷ Passengers must not be in the vehicle when it is jacked up.
- ▷ Before you change a wheel, be sure the ground is level and firm. If necessary, use a board under the jack to ensure that the jack does not sink into the ground.
- ▷ Set the electric parking brake and block the wheels opposite the flat tire on the other side of the vehicle.

- ▷ The jack is only to be used for changing a wheel. Do not use it as a support to work under the car.
- ▷ The car must be jacked up only at the illustrated jacking points. Lifting at any other place may result in personal injury.

NOTICE

Risk of damage to the engine or vehicle if you lift the vehicle improperly.

- ▷ The car must be jacked up only at the illustrated jacking points. Lifting at any other place may result in damage to the vehicle.
- ▷ Never jack up the car by the body, bumpers, engine, transmission or at the axles.
- ▷ Do not damage any sensitive components in the vicinity of the jacking points.
- ▷ For safety reasons do not use tire inflating bottles. Do not use commercially available sealant bottles. Use only the tire inflating bottle located in the luggage compartment.

i Information

The tools required for changing a wheel (e.g. jack, wheel bolt wrench, assembly aids) are not supplied as standard with the vehicle. Your authorized Porsche dealer will be pleased to advise you.

i Information

The tire and wheel sizes on both axles are different.

- ▷ Do not fit the wrong wheels on the wrong axle.
- ▷ Only use wheels/tires with approved dimensions for the relevant axle.

Sequence of operation

⚠ WARNING

Working under vehicle

The jack must be used only to raise the car for wheel changing. The jack must never be used as a support to work underneath the vehicle. If the jack is accidentally dislodged, you or bystanders could suffer severe personal injury.

- ▷ Never jack up other vehicles or other loads with the jack.
 - ▷ Always place the car on stable supports if you have to work under it. When working under the vehicle, always use safety stands specifically designed for this purpose.
-
- ▷ Please use a suitable knee rest to protect your clothing against soiling.
1. Activate the electric parking brake and shift into 1st gear.
 2. Switch on the emergency flasher if necessary.

3. Secure the vehicle to prevent it from rolling away, e.g. by means of wedges under the wheels on the opposite side. This is particularly important on slopes.
4. Slightly loosen the wheel bolts on the wheel to be changed.
5. Lift the vehicle only at the specified jacking points.
6. Raise the vehicle until the wheel lifts off the ground.
 - ▷ Please see the chapter "RAISING THE VEHICLE WITH A LIFTING PLATFORM, TROLLEY JACK OR STANDARD JACK" on page 195.
7. Remove 1 or 2 wheel bolts (see corresponding figure).



3G1_129

Screw in one assembly aid on vehicles **without** PCCB

8. Screw in assembly aid instead of wheel bolts.

NOTICE

Risk of damage to brake disks.

- ▷ Always screw in both assembly aids when changing a wheel.

-
9. Remove the remaining wheel bolts.
 10. Take the wheel off and put a new wheel on.
 - ▷ Please see the chapter "WHEEL BOLTS" on page 199.
 11. Insert wheel bolts and tighten by hand.



3G_130

Screw in two assembly aids on vehicles **with** PCCB

12. Remove assembly aids and screw in remaining wheel bolts.

Initially tighten bolts only slightly in diagonally opposite sequence so that the wheel is centered.

13. Inflate the tire if necessary.

▷ Please see the chapter “TIRE PRESSURE FOR COLD TIRES (68 °F/ 20 °C)” on page 221.

14. Lower the vehicle fully and remove the jack.

15. Tighten wheel bolts in diagonally opposite sequence.

Immediately after changing a wheel, use a torque wrench to check the prescribed tightening torque of the wheel bolts (160 Nm/118 ftlb.).

i Information

Tire Pressure Monitoring System settings on the multi-function display must be updated after a wheel change.

▷ Please see the chapter “TIRE PRESSURE MENU (TIRE PRESSURE MONITORING SYSTEM, TPMS)” on page 86.

Checking tire pressure with a pressure gauge

1. Remove the valve stem cap from the tire.
2. Press the pressure gauge onto the valve stem.

i Information

▷ Do not press too hard or force the valve stem sideways, or air will escape.

If the sound of air escaping from the tire is heard, reposition the pressure gauge.

3. Read the tire pressure on the gauge stem and compare it to the permissible tire pressure. This information can be found on the tire pressure plate or in the chapter Technical Data.
4. Remove the pressure gauge.
5. Please see the chapter “TIRE PRESSURE MENU (TIRE PRESSURE MONITORING SYSTEM, TPMS)” on page 86.

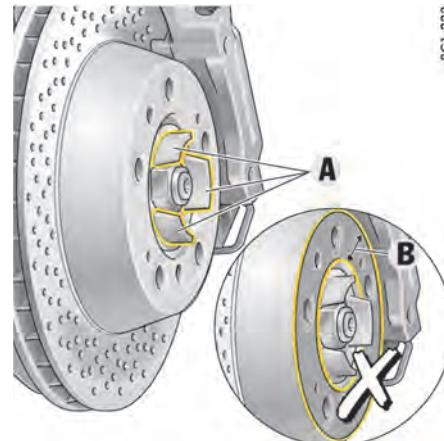

8C1_223

Do **not** grease wheel attachment face **B**

Wheel Attachment Faces

NOTICE

There is a risk of damage to the wheel and wheel attachment face.

- ▷ The wheel attachment face **B** on the brake disk and on the wheel itself must **not** be greased.
- ▷ Only the areas **A** may be greased. Grease these areas very thinly with Optimoly® TA. Do not use any other grease/paste.

Wheel Bolts

- ▷ Always clean the wheel bolts before fitting.
- ▷ Wheel bolts must not be greased.
- ▷ Replace damaged wheel bolts.
Only use genuine Porsche wheel bolts assigned especially to this model or wheel bolts of similar quality that have been manufactured according to Porsche specifications and production requirements.

Tightening torque

Tightening torque for wheel bolts: **160 Nm (118 ftlb.)**.



Security wheel bolts

The adapter (wrench socket) supplied for the security wheel bolts (if fitted) can be stored in the tool kit in the front luggage compartment.

- ▷ If the wheels have to be removed at the workshop, do not forget to hand over the socket for the security wheel bolts along with the car key.
- ▷ To loosen or tighten the wheel bolt with anti-theft protection, the adapter must be used between the wheel bolt and the wheel bolt wrench.
- ▷ When positioning the wrench socket, ensure that it engages fully in the teeth of the wheel bolt.

Flat Tire

1. Stop the vehicle as far away from the driving lane as possible.
The vehicle must be parked on a firm and flat surface offering adequate grip.
2. Switch emergency flasher on.
3. Apply the parking brake.
4. Put the vehicle in 1st gear.
5. Straighten the front wheels.
6. Remove the ignition key, in order to lock the steering and prevent the engine from being started.
7. Get all passengers to leave the vehicle.
8. Set up the warning triangle at a suitable distance.

Filling in tire sealant

The tire sealant can be found in the right-hand box in the front luggage compartment. The compressor is located under the cover in the front luggage compartment.

The tire sealant can be used to seal small cuts, especially in the tire tread.

Sealing the tire with the tire sealant is only an emergency solution so you can drive to the nearest workshop. Even if the tire is air-tight, it may only be used for short journeys in an emergency.

The tire sealant set comprises:

- a filler bottle
- a filler hose
- a valve turner
- a spare valve insert
- a sticker with the maximum permitted speed
- a compressor
- operating instructions

⚠ WARNING

Limits on tire sealant use

Always observe the following points:

- ▷ Use the tire sealant only in the case of cuts or punctures no larger than 0.15 in. (4 mm).
- ▷ Never use the tire sealant if the rim is damaged.

⚠ WARNING

Tire sealant flammability

The sealant is highly flammable and harmful to health.

- ▷ Fire, naked flame and smoking are prohibited when handling tire sealant.
- ▷ Avoid contact with skin, eyes or clothing due to caustic chemical properties of the tire sealant.
- ▷ Keep tire sealant away from children.
- ▷ Do not inhale vapors, due to the consequent harm to personal health resulting in serious personal injury or death.

In the event of contact with sealant:

- ▷ If sealant gets on your skin or into your eyes, thoroughly rinse the affected part of your body immediately with plenty of water.
- ▷ Change soiled clothing immediately.
- ▷ See a doctor immediately in the event of an allergic reaction.
- ▷ If sealant is swallowed, thoroughly rinse out the mouth without delay and drink plenty of water. Do not induce vomiting.
See a doctor immediately.

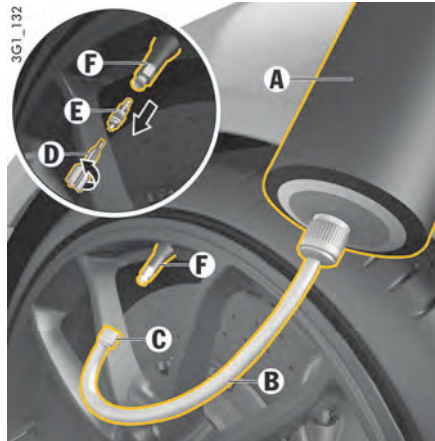

- A - Filler bottle
- B - Filler hose
- C - Filler hose plug
- D - Valve turner
- E - Valve insert
- F - Tire valve

Filling in sealant

1. Leave the object that caused the puncture in the tire.
2. Remove sealant and the enclosed sticker from the front luggage compartment.
3. Stick the sticker in the driver's field of vision.
4. Shake filler bottle **A**.
5. Screw filler hose **B** onto the filler bottle.
The filler bottle is now open.
6. Unscrew valve cap from the tire valve **F**.
7. Remove valve insert **E** from the tire valve with valve turner **D**.
Keep the valve insert in a clean, dry place.
8. Remove plug **C** from the filler hose **B**.
9. Push filler hose onto the tire valve.

10. Hold the filler bottle higher than the level of the tire valve and squeeze it forcefully until the bottle is completely emptied into the tire.

11. Pull filler hose off the tire valve.

12. Screw valve insert **E** securely into the tire valve with the valve turner **D**.

13. Connect the compressor to a socket in the vehicle and inflate the tire to at least 37 psi/ 2.5 bar/25 kPa.

If this tire pressure cannot be reached, the tire is too severely damaged.

Do not continue driving with this tire.

14. Screw valve cap onto the tire valve **F**.

15. Check the tire pressure after driving for around 10 minutes.

If the tire pressure is less than 22 psi/1.5 bar/ 15 kPa, do not continue driving.

If a value of more than 22 psi/1.5 bar/15 kPa is indicated, correct the pressure to the prescribed value.

▷ Please see the chapter "TIRE PRESSURE FOR COLD TIRES (68 °F/ 20 °C)" on page 221.

16. Please contact an authorized Porsche dealer.

▷ Also follow the separate operating instructions for the tire sealing compound.

⚠ WARNING**Pressure loss**

A tire pressure sensor that is soiled with sealant cannot determine the tire pressure correctly.

- ▷ When the defective tire is replaced, the tire pressure sensor must be replaced.
-

⚠ DANGER**Damaged tires**

Damaged tires could burst causing loss of control of the vehicle.

- ▷ Have the tire replaced by a specialist workshop as soon as possible.
 - ▷ Avoid hard acceleration and high cornering speeds.
 - ▷ Observe maximum speed of 50 mph (80 km/h).
 - ▷ Always observe the safety and operating instructions, which can be found in the separate operating instructions for the sealant and on the compressor.
-

Electrical System

In order to avoid damage and faults in electrical or electronic systems, electrical accessories should be installed at an authorized Porsche dealer

- ▷ Use only accessories approved by Porsche.

⚠ WARNING**Changing fuses**

Replacing fuses or relays with the engine running or the ignition on could cause electrical shock.

- ▷ Disconnect the negative terminal on the battery during all work on the electrical system.
 - ▷ Please see the chapter "BATTERY (12 VOLT)" on page 205.
-

Relays

Relays should be checked or changed only at an authorized workshop.

Changing fuses

In order to prevent damage to the electrical system due to short circuits and overloads, the individual circuits are protected by fuses.

The fuse boxes are located in the side walls of the driver's and passenger's footwell respectively.

1. Switch off the load with the defective fuse.
2. Detach the appropriate plastic cover at the finger hole.

3. Remove the relevant fuse (see fuse assignment) from its slot using the yellow plastic gripper **A** (left fuse box) in order to check it.

A blown fuse can be identified by the melted metal strip.

4. Replace only with fuses of the same rating. Spare fuses can be found in the left-hand fuse box, next to the yellow plastic gripper. We recommend that you use genuine Porsche fuses for replacement.

**Information**

If a fuse blows repeatedly, the cause of the fault must be corrected immediately.

- ▷ Please contact an authorized Porsche dealer.
-



A - Plastic gripper
B - Spare fuses

Fuses in left footwell

Row A

No.	Designation	A
1	Lower left: Air-conditioning fan, R/L	40
2	Upper left: PSM control unit	40
3	Lower right: Seat adjustment	25
4	Upper right: PASM control unit	40

Row B

No.	Designation	A
1	Headlight adjustment for LHD/RHD Front lid light Front lid actuator High beam, FL Low beam, FL Side marker light, FR Turn signal lights, RL	40
2	Exhaust flap control Raised brake light, rear wing Rear lid actuator Rear fog light, right Reversing light, left Brake light, left Tail light, left Daytime driving light, FL	15
3	Alarm horn	15
4	Interior lighting Hall sensors Orientation light License plate light Heated rear window relay Central locking LED Door panels LED Ambient light Raised brake light Rear fog light, left Brake light, right Reversing light, right Daytime driving light, FR Tail light, right	15
5	Fuel pump relay	20
6	Filler flap close/open Washer pump	10

No.	Designation	A
7	Not used	
8	Air conditioning control unit	7.5
9	Instrument cluster Steering column Stopwatch	10
10	PCM CAN adapter	25

Row C

No.	Designation	A
1	Center console button panel Gateway control unit Diagnostic socket Ignition lock Passenger compartment monitoring sensor Light switch Front left door control unit Bluetooth phone charger	15
2	Footwell lights Electric ignition lock anti-removal lock Turn signal light indicator, FL/FR Emergency flasher button LED Electric ignition lock light Side turn signal lights, FR/FL High beam, FR Low beam, FR Turn signal light indicator, RR Side marker light, FL	40
3	Vehicle Tracking System control unit	5
4	Horn	15
5	Filler flap	30
6	Power window control unit, FL	25

No.	Designation	A
7	Headlight cleaning system	30
8	PSM control unit	25
9	Alarm siren	5
10	PASM control unit	5

Row D

No.	Designation	A
1	Not used	
2	HomeLink®	5
3	Left headlight	5
4	PDC control unit Gateway/diagnostic socket Air quality sensor Gateway headlights	5
5	PSM control unit	5
6	Steering column switching module Electronic steering gear Refrigerant pressure sensor	5
7	Clutch switch sensor	5
8	Right headlight	5
9	Interior mirror	5
10	Not used	

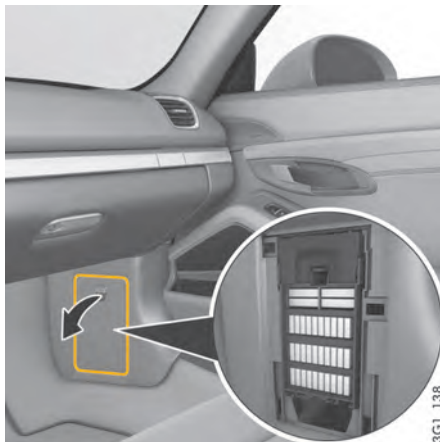

Fuses in right footwell

Row A

No.	Designation	A
1	Not used	40
2	Not used	40
3	Lower right: Fresh-air blower motor Blower regulator	40
4	Upper right: Right seat control unit Seat adjustment	25

Row B

No.	Designation	A
1	Rain sensor	5
2	Air conditioning control unit	25
3	Not used	
4	Not used	
5	RDK control unit	5
6	TV tuner	5
7	Not used	
8	Not used	
9	Not used	
10	Not used	

Row C

No.	Designation	A
1	Heated rear window	30
2	Electric parking brake button	5
3	PASM control unit	5
4	Not used	
5	Temperature sensor Tank leakage diagnosis	5
6	Wiper motor	30
7	Power window control unit, FR	25
8	Steering column adjustment	25
9	Roof console	5
10	Not used	

Row D

No.	Designation	A
1	Airbag control unit	5
2	PASM control unit	5
3	Not used	
4	Not used	
5	Occupant sensing for the passenger's seat	5
6	Not used	
7	Control units DME, VTS, BCM back	5
8	Socket in passenger footwell	20
9	Center console socket Cigarette lighter	20
10	Socket in glove box	20

Emergency unlocking of front luggage compartment lid

If the battery is discharged, the front luggage compartment lid can be opened only with the aid of a donor battery.

Information

The engine **cannot** be started with this method.

- ▷ Please see the chapter “EXTERNAL POWER SUPPLY, EMERGENCY STARTING WITH JUMPER CABLES” on page 207.

Unlocking lids

1. Use the key to unlock the vehicle at the door lock.
2. Remove the plastic cover from the left-hand fuse box.
3. Pull out positive terminal **C** (red) in the fuse box using the plastic gripper **A** (yellow).

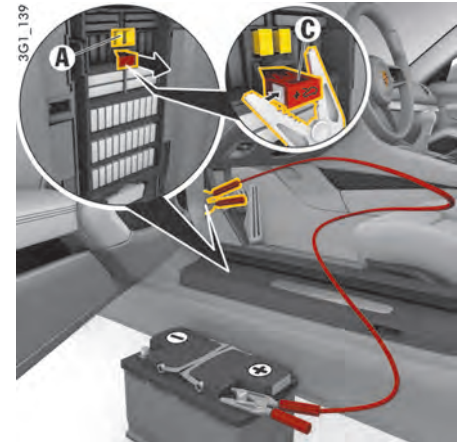

A - Plastic gripper (yellow)

C - Positive terminal (red)

4. Use the red jump lead to connect the positive terminal of the donor battery to the positive terminal **C** in the fuse box.

Information

If the vehicle was locked, the alarm horn will sound when the negative lead is connected.

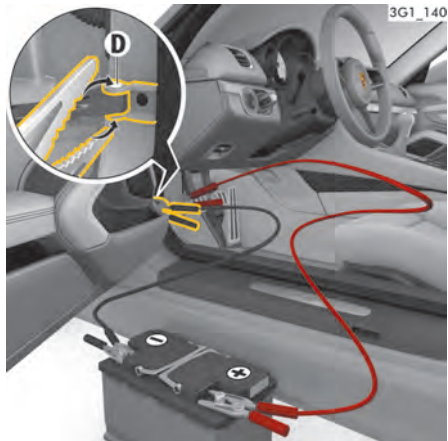

5. Use the black jump lead to connect the negative terminal of the donor battery to the door arrester **D**.
6. Press button **2** on the remote control for approx. 2 seconds to unlock the luggage compartment lid. The alarm system is switched off.
7. Disconnect the negative lead first, then the positive lead.
8. Push positive terminal **C** into the fuse box and fit the plastic fuse box cover.

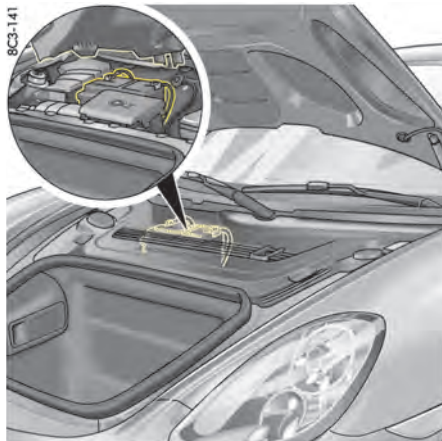

Battery (12 volt)

The battery is located under the cover in the front luggage compartment.

For information on removing the cover:

- ▷ Please see the chapter "TIRE FILLING COMPRESSOR" on page 148.
- ▷ Have the battery removed and installed only by your authorized Porsche dealer.

⚠ DANGER Electric shock

- ▷ Observe all warning notes on the battery.
- ▷ Disconnect the negative terminal on the battery during all work on the electrical system.
- ▷ Do not lay tools or other metal objects on the battery as they could cause a short circuit across the battery terminal.

⚠ DANGER Battery explosion hazard

- ▷ Charge battery in a well ventilated area.
- ▷ Never charge a frozen battery. It may explode because of gas trapped in the ice. Allow a frozen battery to thaw out first.
- ▷ Do not expose the battery to an open flame, electrical spark or a lit cigarette, since they can ignite hydrogen gas from the battery.

⚠ DANGER Static electricity

- ▷ Do not wipe the battery with a dry cloth.
- ▷ Before touching the battery, discharge any static electricity by touching the vehicle.

⚠ WARNING Chemical exposure

- ▷ After handling battery, always protect your skin and remove surface chemicals by washing thoroughly with soap and water.

⚠ WARNING Battery acid and electrolyte exposure

- ▷ Wear eye protection.
- ▷ Do not allow battery acid to come in contact with your skin or eyes.
- ▷ If you get electrolyte, which is an acid, in your eyes or on your skin, immediately rinse with cold water for several minutes and call a doctor.

NOTICE

Risk of damage to the fabric, metal or paint from battery acid or electrolyte.

- ▷ Do not allow battery acid to come in contact with fabric or painted surfaces.
 - ▷ Spilled electrolyte must be rinsed off at once with a solution of baking soda and water to neutralize the acid.
-

Charge state

A well-charged battery prevents starting problems and has a longer service life.

In order to avoid unintentional battery discharge:

- ▷ Switch off unnecessary electrical loads in city traffic, on short trips or in a line of traffic.
- ▷ Always remove the ignition key when leaving the vehicle or
- ▷ Avoid using the Porsche Communication Management system and the audio system when the engine is not running.
- ▷ Please see the chapter "CHARGING THE BATTERY" on page 208.



Information

In the cold season in particular or if the vehicle is used primarily for short distances, it may be necessary to recharge the battery from time to time.

Battery care

- ▷ Ensure that battery is securely mounted.
- ▷ Keep battery surface clean and dry.
- ▷ Keep terminals and connections clean. Corrosion can be prevented by coating the terminals and connections with petroleum jelly or silicone spray.
- ▷ Ensure that terminal clamps and the vent hose are firmly secured.

Winter driving

The ability of the battery to deliver and store power decreases at low outside temperatures. Moreover, the battery is more heavily loaded in the winter months, e.g. by the heated rear window, the more frequent use of additional lights, the blower and the windshield wipers, etc.

- ▷ Have the battery checked before the start of winter.



Information

Keep the battery fully charged to prevent it from freezing.

A discharged battery can already freeze at 23 °F (−5 °C), but a fully charged one only freezes at −40 °F (−40 °C).

- ▷ If the battery is frozen, thaw it out before connecting jump leads.
-

Storing the vehicle

If the vehicle is left for long periods in the garage or workshop, the doors and lids should be closed.

- ▷ Remove the ignition key or disconnect the battery if necessary.



Information

- ▷ When the battery is disconnected, the alarm system ceases to function. If the vehicle was locked before the battery was disconnected, the alarm will be triggered when the battery is reconnected. To deactivate the alarm system:
 - ▷ Lock the vehicle and unlock it again.
-

Alarm system, central locking

- ▷ The status of the central locking and alarm system does not change when you disconnect the battery.



Information

Even if you put your vehicle out of operation, the battery still discharges.

- ▷ The battery must be charged, i.e. connected to a charger, approximately every 6 weeks in order to preserve battery function.
 - ▷ Store a battery that has been removed in a dark, cool place that is not exposed to frost.
-

Replacing the battery

The battery is subject to normal wear: its service life depends heavily on the care you give it, climatic conditions and the conditions of use (distances, loads).

It is not possible to use the details on the battery case to determine a comparable battery that meets all the specific requirements of Porsche.

- ▷ Have the battery removed and installed only by your authorized Porsche dealer.
- ▷ Only use an original Porsche battery, with the correct part number, as a replacement. Only this battery meets the specific requirements of the vehicle.
- ▷ After you install a new battery, it must be initialised in the control unit. Please contact your authorized Porsche dealer.
- ▷ Please observe the disposal instructions for batteries.

Putting vehicle into operation

After connecting the battery or changing an exhaustively discharged battery there are a few simple steps necessary:

- 1.** Store the end position for the power windows.

For information on storing the end positions for the power windows:

- ▷ Please see the chapter “STORING END POSITION OF THE WINDOWS AFTER CONNECTING THE VEHICLE BATTERY” on page 62.

- 2.** Teach tires.

For information on teaching the Tire Pressure Monitoring System:

- ▷ Please see the chapter “TIRE PRESSURE MENU (TIRE PRESSURE MONITORING SYSTEM, TPMS)” on page 86.

- 3.** Store end position on vehicles with a slide/tilt roof.

For information on storing the end position for the slide/tilt roof:

- ▷ Please see the chapter “STORING END POSITION OF THE WINDOWS AFTER CONNECTING THE VEHICLE BATTERY” on page 62.

External Power Supply, Emergency starting with jumper cables

If the battery is flat, the battery of another vehicle can be used for starting or as an external power supply with the help of jump leads.

Both batteries must be 12 V batteries. The capacity (Ah) of the donor battery must not be substantially less than that of the flat battery.

The flat battery must be connected correctly to the vehicle's electrical system.



WARNING

Jumper cable hazards

A short circuit may be caused if unsuitable jumper cables are used or if jumper cable starting is not performed properly. Such short circuits can cause a fire.

- ▷ Use only standard jumper cables with sufficient cross section and completely insulated alligator clips. Follow the instructions provided by the jumper cable manufacturer.
- ▷ Route the jumper cables so that they cannot be caught by moving parts in the engine compartment.
The jumper cables must be long enough so that neither vehicles nor cables touch another.
- ▷ The vehicles must not touch, otherwise current might flow as soon as the positive terminals are connected.
- ▷ Ensure that tools or conductive jewelry (rings, chains, watch straps) do not come into contact with the positive jumper cable, the positive battery post or live parts of the vehicle.
- ▷ Improper hook-up of jumper cables can ruin the alternator.

⚠ WARNING

Battery acid leakage

- ▷ Do not lean over the battery due to danger of chemical burns from leaking acid.

⚠ DANGER

Battery charging and jumping hazards

- ▷ Improper use of booster battery to start a vehicle may cause an explosion.
- ▷ Keep sources of ignition away from the battery, e.g. naked flame, burning cigarettes or sparks due to cable contact.
- ▷ Before connecting jumper cables, it is essential to thaw out a frozen battery.

NOTICE

Risk of damage due to short circuit.

- ▷ Never connect jumper cables directly to the battery. Always connect jumper cables to the emergency starting terminals in the luggage compartment.

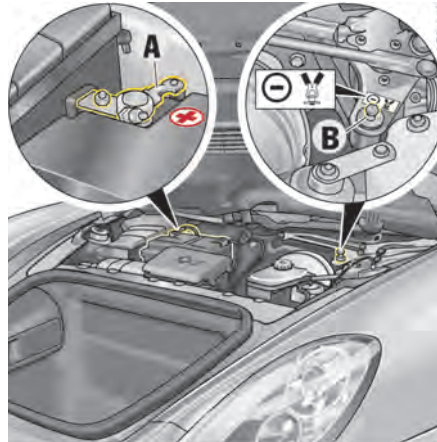

- + = Battery positive terminal **A**
- = Ground point for external power supply/emergency starting **B**

Supplying external power/ Performing emergency starting with jumper cables

Always observe the sequence below:

1. Remove cover in front luggage compartment.
To remove the cover:
Please see the chapter "TIRE FILLING
COMPRESSOR" on page 148.
2. Connect the positive lead (red) to the positive terminal **A** of the discharged battery first, then connect it to the positive terminal of the donor battery.
3. Connect the negative lead (black) first to the negative terminal of the donor battery, then to the ground point **B**.
4. Leave the engine of the donor vehicle running at a higher engine speed.

5. Start the engine.

An attempted start using jump leads should not last more than 15 seconds. Then wait for at least one minute.

6. With engine running:

Disconnect the negative lead from the ground point **B** first, then from the negative terminal of the donor battery.

7. With engine running:

Disconnect the positive lead from the positive terminal of the donor battery first, then from the positive terminal **A** of the discharged battery.

Charging the battery

Automotive batteries lose their efficiency when not in use. The charge available in your battery can be measured with a battery hydrometer. We recommend that the battery voltage be tested by your authorized Porsche dealer who has the appropriate equipment.

If the car is not driven for prolonged periods, the battery must be charged at least every 6 weeks. A discharged battery allows rapid formation of sulfates, leading to premature deterioration of the plates.

⚠ DANGER

Battery explosion hazards

- ▷ Charge battery in a well ventilated area due to hydrogen gas explosion risk.
- ▷ Never charge a frozen battery. It may explode because of gas trapped in the ice. Allow a frozen battery to thaw out first.

⚠ CAUTION

Eye or skin contact

- ▷ If you get electrolyte, which is an acid, in your eyes or on your skin, immediately rinse with cold water for several minutes.

Your authorized Porsche dealer will be pleased to advise you about a suitable charger.

- ▷ Always observe the instructions provided by the charger manufacturer.
 - ▷ If the battery is frozen, thaw it out first before charging it.
 - ▷ When charging the battery, ensure adequate ventilation.
1. Connect the charger to the emergency starting terminals.
Only plug into the mains and switch the charger on when it is connected up correctly.
 2. Switch on the charger.
 3. After charging the battery, first switch off the charger and then disconnect it.
- ▷ Please see the chapter "PUTTING VEHICLE INTO OPERATION" on page 207.

Changing Car Key (Remote Control) Battery

i Information

- ▷ Please observe the regulations for disposing of batteries.

Car key

If the battery in the remote control becomes too weak, the message "**Replace ignition key battery**" will appear on the multi-function display in the instrument panel.

The battery should be changed in this case.

9F3-143

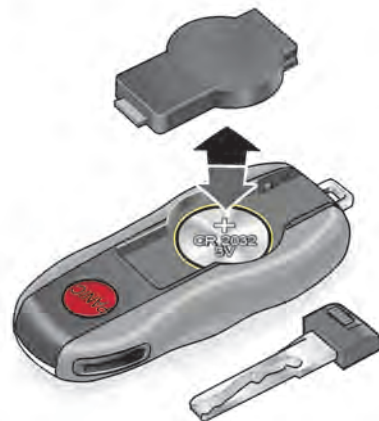

Changing the battery (CR 2032, 3 V)

1. Remove the emergency key.
For information on the emergency key:
 - ▷ Please see the chapter "EMERGENCY KEY" on page 19.
2. Lever off the cover on the back of the key housing using a small screwdriver.
3. Change the battery (check polarity).
4. Re-fit cover and press together firmly.
5. Insert the emergency key.

Replacing bulbs

Bulb Chart

Bulb for	Type	Power
Additional high beam, Bi-Xenon™/Bi-Xenon™ with PDLs	H7	55 W
Side marker lights	WY	5 W

Replacing Light-Emitting Diodes and Long-Life Bulbs

Daytime driving lights, front side lights, rear turn signal lights, gas-discharge bulbs in Bi-Xenon™ headlights, tail lights, fog/reversing lights, license plate lights, additional brake light and interior lights are equipped with light emitting diodes and long-life bulbs.

The LEDs cannot be replaced individually.

Replacement of the long-life bulbs involves a greater amount of installation work.

- ▷ Have defective LEDs and long-life bulbs replaced at an authorized Porsche dealer.

WARNING

Electric shock

Bi-Xenon™ headlights are under high voltage.

- ▷ Exercise extreme care when working close to the headlights.
- ▷ Switch off the lights and ignition before replacing bulbs.

NOTICE

Risk of damage from bulbs with incorrect wattage. Bulbs of a high wattage can damage the housing.

NOTICE

Risk of damage due to short circuit.

- ▷ Always switch off the relevant load when changing bulbs.



Information

Bulbs must be clean and free from grease.

- ▷ Never touch bulbs with your bare hands. Use a cloth or soft paper when replacing bulbs.
- ▷ Always carry spare bulbs with you. In certain countries, it is mandatory to carry spare bulbs.

Headlights

NOTICE

Risk of damage to headlights due to abrasion and excessive temperatures.

- ▷ Do not affix any coverings (e.g. “stone guards” or film) close to the headlights.
- ▷ Use soapy water only to clean light lenses and plastic headlight lenses. In no case may chemical cleaners or other volatile cleaning fluids be used.
- ▷ To prevent scratches, do not rub with a dry or merely moist cloth, tissue or insect sponges.



Information

The headlights can mist up due to temperature and humidity. This misting will disappear after you have driven a sufficient distance.

- ▷ To ensure optimum ventilation, do not cover the gap between headlight and body.

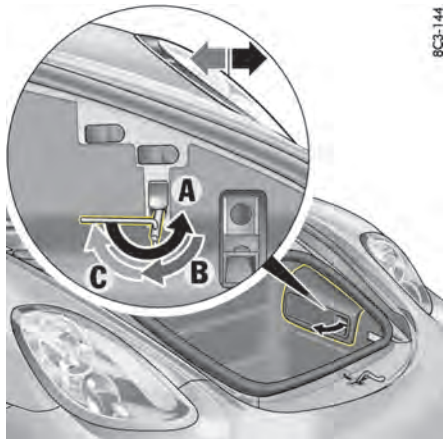

BC3-144

Installing headlights

1. Attach plug (clearly audible clicking sound).
2. Insert headlight into the guide rails and push fully into the wing.
3. Push headlight to the rear and at the same time turn the socket wrench until it points horizontally to the rear **C**.
You should feel and hear the headlight locking mechanism engage.
4. Close the cover for the headlight release mechanism.
5. Attach tool box.
6. Check function of all bulbs.

▽

Removing headlights

1. Open front luggage compartment lid.
2. Remove the relevant toolbox.
3. Open up the cover for the headlight release mechanism.
4. Place socket wrench (tool kit) on the unlocking spindle.
The handle of the wrench should point horizontally to the rear.
5. Turn wrench approx. 180° **A**. This unlocks the headlight and pushes it forward slightly.
6. Turn socket wrench back until it is pointing vertically downwards **B** and leave in position.
7. The headlight is now unlocked and can be pulled forward out of the wing by lifting slightly.
8. Detach plug.

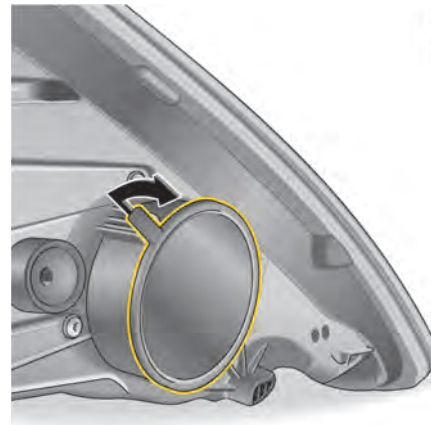

BC1-193

Changing bulb for turn signal light

Opening the cover of the headlight housing

1. Remove the headlight.
▷ Please see the chapter "REMOVING HEADLIGHTS" on page 211.
2. Remove the housing cover by pulling on the tab (**illustration**).



3. Remove the bulb holder **A**.
 4. Replace defective bulb (bayonet lock).
 5. Insert the bulb holder **A** into the guide and push it in as far as it will go.
 6. Close the housing cover.
 7. Install the headlight and check operation of bulb.
- ▷ Please see the chapter "INSTALLING HEADLIGHTS" on page 211.

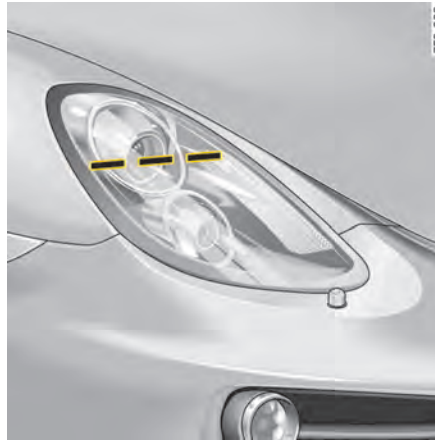

Headlight Adjustment

- ▷ Check tire pressure and adjust if necessary.
- ▷ Please see the chapter "TIRE PRESSURE FOR COLD TIRES (68 °F/ 20 °C)" on page 221.
- ▷ Please see the chapter "REPLACING LIGHT-EMITTING DIODES AND LONG-LIFE BULBS" on page 210.

Adjustment

The adjustment is made with the vehicle ready to drive and the fuel tank completely filled.

The driver's seat must be loaded by a person or a 165 lbs. (75 kg) weight and the tire pressures must meet the prescribed values. After being loaded, the car must be rolled a few meters so that the suspension can settle.

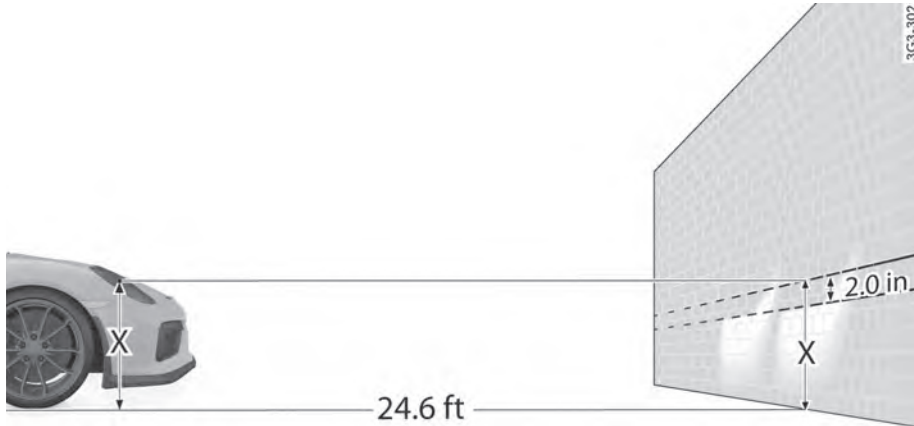

For checking the headlight adjustment, the vertical position of the cutoff of the lowbeam (see fig.) has to be projected on a vertical screen (wall) in distance of 24.6 ft. (7.5 m) from the front lens of the headlamp. The correct position of the cutoff is 2.0 in. (5 cm) at 24.6 ft. or 7.5 m (0.4°) below a horizontal line, x cm from ground to the center of the headlamp lens.

Lateral adjustment of the headlights should be carried out at a specialist workshop with an optical adjustment unit.

Distance

Visual aim shall be performed at not less than 24.6 ft. (7.5 m) (this value is a rounded down conversion from the 25-foot distance typical of field aim using a screen). The 24.6 ft. (7.5 m) distance is measured from the headlamp lens to the viewing screen.

Floor

The surface upon which the vehicle rests is flat and approximately level.

Screen

The screen upon which headlamp beams are projected is perpendicular to the floor and the vehicle's longitudinal axis, flat, uniformly light in color, unobstructed, and wide and high enough to accommodate the vehicle beam patterns to be aimed.

The screen should be wide enough to provide at least 3.3 ft. (1 m) of space outboard of the vehicle's headlamp spacing.

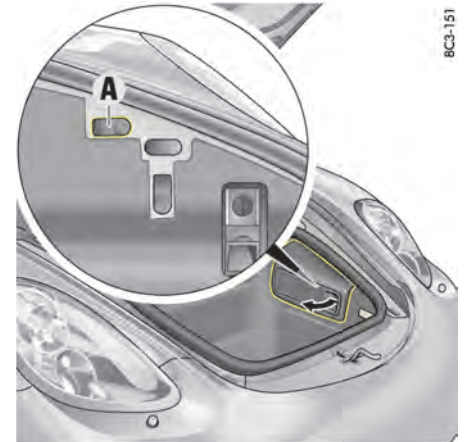

A - Height adjustment

Height adjustment

1. Switch ignition on.
2. Switch on low beam.
3. Open front luggage compartment lid.
4. Remove the relevant toolbox.
5. Open up the cover **A** for the adjusting screw.
6. Place allen key (5 mm) on adjusting screw.
7. Adjust low beam in the corresponding direction.

Towing

Certain state statutes and local ordinances prohibit towing with a chain, rope or even a tow bar. In addition, damage to your vehicle may result from improper procedures. Consult your authorized Porsche dealer for details.

Flat bed towing is the preferred type of towing to be used on Porsche vehicles.



Information

- ▷ Always observe the laws governing towing and tow-starting.
- ▷ Exercise extreme care when your vehicle is being towed.



WARNING

Towed vehicle hazards

No power assistance is available on the towed vehicle when its engine is not running. Greater force is therefore required when braking and steering.

- ▷ Exercise extreme care when your vehicle is being towed.

When the engine is not running, adequate lubrication of the transmission is not warranted. Observe the following points to avoid damage to the transmission.

Towing a vehicle with manual transmission on all four wheels:

- ▷ Put the gearshift lever in neutral.
- ▷ The vehicle must always roll on all four wheels when towed.
The ignition must be switched on so that the brake lights and turn signal lights operate.

Towing a vehicle with manual transmission on one axle:

- ▷ Switch ignition off.
- ▷ Put the gearshift lever in neutral.
- ▷ Make sure that the vehicle is adequately illuminated.
- ▷ Do not exceed a maximum speed of 30 mph (50 km/h).
Maximum towing distance 30 miles (50 km).
If towing distances are greater, the vehicle must be transported with a car transporter or on a trailer.

Pulling out a vehicle stuck in snow, sand, etc.

- ▷ Always pull out the stuck vehicle with the greatest care.
- ▷ Do not pull out the vehicle abruptly or at an angle.
- ▷ If possible, pull the vehicle out backwards in its own tracks.

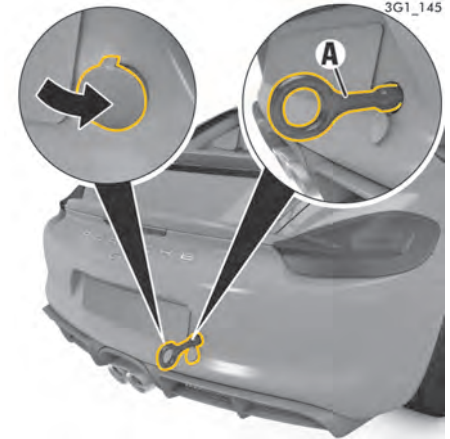

3G1_145

Rear towing lug

Fitting the towing lug

1. Press the lower edge of the appropriate plastic cover into the bumper until the cover disengages.
2. Pull cover out of the bumper and let it hang by its thread.
3. Screw in towing lug **A** as far as it will go (left-hand thread) and tighten hand-tight.

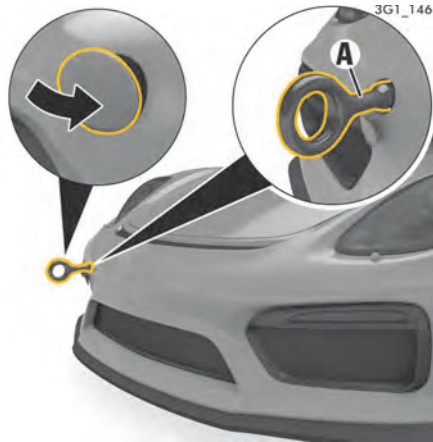

Front towing lug

Removing the towing lug

1. Unscrew the towing lug **A**.
2. Insert plastic cover at the lower edge of the opening.
3. Fold the cover up and press on its upper edge to engage it in the bumper.
4. Store the towing lug in the tool box.



Pulling vehicle onto flat bed

1. Position wooden ramps at the base of the flat bed to reduce the angle of the pull.
2. Reel in the hoist cable and check the underside of the vehicle for any interference.



Tying down vehicle on flat bed

1. Carefully feed towing straps through the opening in the **rear wheels**.
Make sure metal parts of straps do not damage rim.
Make sure the strap is flat over the rim bead.
Make sure brake backing plate is not damaged.
2. Secure straps to rear of flat bed.
3. Reel in hoist cable only far enough to tension tie-down straps.

Transporting the vehicle on car trains, ferries and car transporters

- ▷ Tie the vehicle down only at its wheels.
- ▷ Deactivate interior surveillance and the inclination sensor.
- ▷ Please see the chapter "ALARM SYSTEM AND PASSENGER COMPARTMENT MONITORING" on page 159.



Fire extinguisher

Vehicles with Club Sport package

In vehicles with a fire extinguisher, the extinguisher is attached in the passenger's footwell.

- ▷ To remove the fire extinguisher in the event of an emergency, hold the extinguisher with one hand and release both locking elements **A** on the fire extinguisher holder with the other hand.



Vehicles without Club Sport package

In cars with a fire extinguisher, the extinguisher is located under the front passenger seat.

- ▷ To remove the fire extinguisher in case of an emergency, hold the extinguisher with one hand and press the button **PRESS** on the fire extinguisher holder with the other hand (**arrow**).



Information

- ▷ Check the final inspection date on the fire extinguisher. If the fire extinguisher is used after its inspection interval has elapsed, it may not work properly.
- ▷ Always read the operating instructions on the fire extinguisher.
- ▷ Observe the fire extinguisher manufacturer's safety instructions on the label at the fire extinguisher handle.
- ▷ The fire extinguisher should be checked to ensure correct operation by a specialist workshop every 1-2 years.
- ▷ Have the fire extinguisher refilled after use.

Tire Pressure and Technical Data

Vehicle Identification Data	218
Engine Data	219
Wheels, Tires	220
Tire Pressure for Cold Tires (68 °F/ 20 °C) ...	221
Weights	222
Filling Capacities	223
Driving Performance.....	224
Chassis Setup.....	224
Engine Diagram at Full Load.....	225



Vehicle identification number

Vehicle Identification Data

When ordering spare parts or making inquiries, please always quote the vehicle identification number.

Vehicle identification number

You will find the vehicle identification number at the bottom left behind the windshield in the direction of travel and under the front passenger's seat.



Identification plate

Safety compliance sticker

The safety compliance sticker is your assurance that your new Porsche complies with all applicable Federal Motor Vehicle Safety Standards which were in effect at the time the vehicle was manufactured.

The sticker also shows the month and year of production and the vehicle identification number of your car (perforations) as well as the **Gross Vehicle Weight Rating** and the **Gross Axle Weight Rating**.



Tire pressure plate

Tire pressure plate

The tire-pressure plate is attached to the B-pillar in the driver's door sill area.

Vehicle data carrier

You will find the vehicle data carrier in the "Maintenance" booklet. It contains all important data about your vehicle. This data carrier cannot be re-ordered if it is lost or damaged.

Engine Data

	Cayman GT4
Number of cylinders	6
Displacement	231.9 cu. in. (3,800 cm ³)
Max. engine output as per 80/1269/EEC	283 kW (385 hp)
At engine speed	7,400 rpm
Max. torque as per 80/1269/EEC	420 Nm (309,7 ftlb.)
At engine speed	4,750 – 6,000 rpm
Maximum permitted engine speed	7,800 rpm

Wheels, Tires

- ▷ Approval of tire and wheel sizes is granted based on extensive testing. Your authorized Porsche dealer will be pleased to advise you about the current approval status.
By fitting tires that have been approved by Porsche, you can be sure that you have the best possible tires for your Porsche.
The load capacity coefficient (e.g. "92") and maximum speed code letter (e.g. "Y") for permitted top speed are minimum requirements.
When fitting new tires or changing tires: Please see chapter "TIRES AND WHEELS" on page 186.
- ▷ Snow chain clearance can only be warranted with the tires marked ¹⁾. Snow chains can only be fitted on the rear wheels. Observe state- or province-specific laws regarding maximum speeds with fitted snow chains. Only use Porsche approved fine-link cross-type or edge chains.

Cayman GT4	
20-inch wheel FA / RA	8,5J x 20, RO 61 / 11J x 20, RO 50
Summer tires FA / RA	245/35 ZR20 (91Y) / 295/30 ZR20 (101Y) XL
Snow tires FA / RA	245/35 R20 91V M+S / 295/30 R20 97V M+S
<hr/>	
20-inch wheel FA / RA	8,5J x 20, RO 57 / 10J x 20, RO 50 ¹⁾
Snow tires FA / RA	235/35 R20 92V M+S / 275/30 R20 97V M+S ¹⁾

FA = front axle, RA = rear axle



DANGER

Improper tire size

Installation of sizes not authorized by Porsche may impair driving stability and could result in loss of control of the vehicle.

Before mounting new tires check with your authorized Porsche dealer for a current list of approved tires.

Tire Pressure for Cold Tires (68 °F/ 20 °C)

The standard and comfort tire pressure applies only to the tire makes and types approved by Porsche.

▷ Please see chapter "TIRE PRESSURE MENU (TIRE PRESSURE MONITORING SYSTEM, TPMS)" on page 86.

Standard tire pressure for summer tires

	20-inch wheels	
	FA	RA
Cayman GT4	29 psi/ 2.0 bar/ 200 kPa	33 psi/ 2.3 bar/ 233 kPa

FA = front axle, RA = rear axle

Standard tire pressure for snow tires

	20-inch wheels	
	FA	RA
Cayman GT4	36 psi/ 2.5 bar/ 250 kPa	36 psi/ 2.5 bar/ 250 kPa

FA = front axle, RA = rear axle

Weights

Cayman GT4

Empty weight (depending on equipment) per DIN 70020	2955 lbs. to 3109 lbs. (1,340 kg to 1,410 kg)
Empty weight (depending on equipment) per 70/156/EEC ¹⁾	3120 lbs. to 3274 lbs. (1,415 kg to 1,485 kg)
Maximum axle load, front ²⁾	1731 lbs. (785 kg)
Maximum axle load, rear ²⁾	1995 lbs. (905 kg)
Maximum Gross vehicle weight ²⁾	3616 lbs. (1,640 kg)

¹⁾ Curb weight includes 165 lbs. (75 kg) driver and baggage share.

²⁾ The maximum vehicle weight and maximum axle loads must not be exceeded.

Notice: If additional accessories are installed, the maximum load will be correspondingly less.

Filling Capacities

Only use fluids and fuels approved by Porsche. Your authorized Porsche dealer will be pleased to advise you.

Engine oil change quantity with oil filter	Approx. 1.98 US gallons (7.5 liters)
Engine oil specification	Porsche A40; SAE 0W - 40, SAE 5W - 40, SAE 5W - 50 ▷ Please see chapter "TOPPING UP ENGINE OIL" on page 166.
Fuel tank	Approx. 14.26 US gallons (54 liters) including approx. 2.64 US gallons (10 liters) reserve optional approx. 16.91 US gallons (64 liters) including approx. 2.64 US gallons (10 liters) reserve
Fuel octane rating	The engine is designed to provide optimum performance and fuel consumption if unleaded premium fuel with 98 RON/88 MON (93 CLC or AKI) is used. ▷ Please see chapter "FUEL" on page 171.
Windshield/headlight washer system	Approx. 1.59 US gallons (6 liters)

Driving Performance

The specifications refer to a vehicle with DIN curb weight without performance-reducing additional equipment (e.g. special tires).

	Cayman GT4
Maximum speed	183,3 mph (295 km/h)
Acceleration 0 to 100 km/h (62 mph)	4.4 seconds

Dimensions

	Cayman GT4
Length	174.7 in. (4,438 mm)
Width without exterior mirrors	71.5 in. (1,817 mm)
Width with exterior mirrors	77.9 in. (1,978 mm)
Height at DIN curb weight	49.9 in. (1,266 mm)
Wheelbase	97.8 in. (2,484 mm)
Ground clearance at maximum gross weight	4.1 in. (105 mm)
Turning circle	37.4 ft. (11,4 m)

Chassis Setup

	Cayman GT4
Driving on public roads and on race circuits	
Front axle overall toe-in	+2' ±2'
Rear axle toe-in per wheel	+10' ±2'
Front axle camber	-1°30' ±3'
Rear axle camber	-1°30' ±5'

The anti-roll bars can be individually adjusted at the front and rear axles. We recommend using the standard setting including on the race circuit. When used on public roads, the chassis must be in the standard setting.

▷ Important notes on chassis setup are included in the separate brochure "DRIVING ON THE RACE CIRCUIT".

Engine Diagram at Full Load

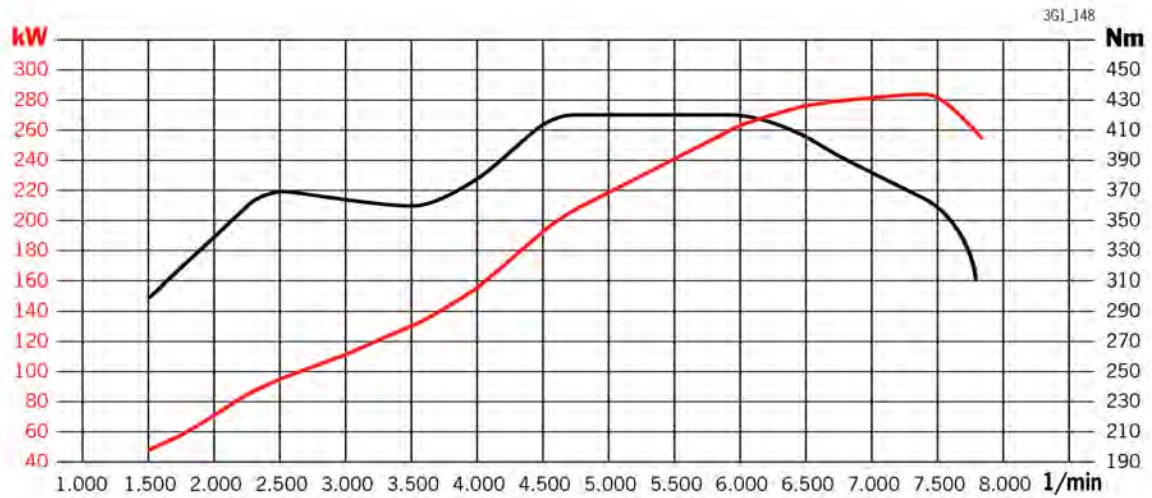

Index

- A**
- A/C button
 - Air-conditioning system51, 55
 - A/C MAX button
 - Air-conditioning system52, 56
 - ABD (automatic brake differential)
 - Functional description136
 - ABS (Anti-lock Brake System)
 - Functional description138
 - Acoustic signals77
 - Adapting fuel gauge102
 - Adaptive light system, driving light assistant64
 - Adhesive foils, care instructions178
 - Adjusting seat position31
 - Aftermarket Alarms127
 - Air cleaner, maintenance instructions186
 - Air conditioning
 - Manual air conditioning51
 - Setting air quantity53
 - Air distribution50, 54, 58
 - Air vents
 - Adjusting59
 - Opening/closing59
 - Airbag
 - Airbag warning light on the tachometer39
 - Automatic deactivation of the passenger airbag...38
 - Care instructions179
 - Disposal37
 - Function37
 - Functional description35
 - Installation location35
 - Passenger airbag warning light39
 - Air-conditioning compressor
 - Information on air-conditioning compressor51, 55
 - Air-conditioning system
 - Automatic load switch-off51, 55
 - Defrosting windshield49, 52
 - Extended ventilation panel58
 - Information on air-conditioning compressor51, 55
 - Manual air conditioning49
 - Setting air distribution54, 58
 - Setting air quantity50, 57
 - Setting automatic air-recirculation mode57
 - Setting temperature50, 53, 57
 - Switching A/C MAX mode on/off52, 56
 - Switching A/C mode on/off51, 55
 - Switching air-conditioning compressor on/off .51, 55
 - Switching air-recirculation mode on and off49, 53, 56
 - SYNC (MONO) mode55
 - Temperature sensor54
 - Air-recirculation button
 - Air-conditioning system49, 53, 56
 - Alarm button18
 - Alarm system
 - Avoiding false alarms160
 - Functional description159
 - Persons/animals remaining in the locked vehicle 159
 - Switching off159
 - Switching off interior surveillance and inclination sensor159
 - Switching on159
 - Alcantara®, care instructions180
 - Alloy wheels
 - Care instructions178
 - Inscription195
 - Alternator
 - Vehicle electrical system warning77
 - Aluminum rims
 - Care instructions178
 - Inscription195
 - Ambient lighting68
 - Antifreeze
 - in coolant184
 - in washer fluid167
 - Anti-lock brake system (ABS)
 - Functional description138
 - Anti-slip control (ASR)
 - Functional description136
 - Armrest
 - Opening oddments tray144
 - Ashtray
 - Emptying146
 - Opening146
 - ASR (Anti-slip control)
 - Functional description136
 - Audio
 - Tips126
 - Audio interface, installation position128
 - AUTO (light switch)64
 - Driving light assistant64
 - Automatic brake differential (ABD)
 - Functional description136
 - Automatic Coming Home lights, courtesy lighting
 - Entry function65
 - Welcome Home function65
 - Automatic speed control (cruise control)
 - Accelerating125
 - Decelerating125
 - Functional description124
 - Interrupting operation125
 - Storing speed125
 - Switching off126
 - Switching on125
 - AUX interface, installation position128
- B**
- Baby seat
 - Installing with Top Tether system43
 - Prescribed installation direction (depending on weight of child)40
 - Top Tether restraint system43
 - Battery
 - Care206
 - Changing in car key209
 - Charging208
 - Emergency starting with jumper cables207
 - General information205
 - Installation position205
 - Procedure after connection207
 - Replacing207
 - Vehicle electrical system warning77
 - Winter driving206
 - Before driving off5
 - Belts
 - Care instructions180
 - Fastening34
 - Opening belt buckle35
 - Safety-belt pretensioners, functional description ...34
 - Warning light on the tachometer34
 - Brake booster123
 - Brake disks3
 - Brake fluid3
 - Changing185
 - Warning light on speedometer185
 - Brake pads3
 - Breaking in new brake pads7
 - Warning message, brakes123
 - Brake pedal122

Brake wear			
Warning message.....	123	Car washing	175
Brakes		Carpet	179
Applying/releasing parking brake.....	120	Fabric linings.....	180
Brake pad warning message	123	Headlights, plastic components, adhesive foils...	178
Brake pedal	122	Leather	179
Brake wear warning message	123	Leather care for seats with seat ventilation	179
Break in new brake pads.....	7	Mats	179
Footbrake.....	121	Paint	176
General information	5	Safety-belts	180
Test stand	164, 183	Seals	178
Break in hints	7	Underbody protection	177
Breaking in		Use of high-pressure cleaning equipment.....	175
Engine.....	7	Wheel attachment faces	198
Engine oil and fuel consumption during		Wheel bolts	199
break-in period.....	7	Windows	177
Hints	7	Carpet, care instructions	179
New brake pads and brake disks.....	7	Catalytic converter	169
New tires	7	Emission control (Check Engine)	77
Brief overview		Center armrest	
Opening and locking the vehicle from outside	20	Opening oddments tray	144
Bulbs		Central locking.....	23
Overview	210	Driver's door emergency operation,	
C		Passenger's door emergency operation.....	28
Car care		Locking vehicle door with car key	
Airbags	179	(remote control).....	22
Alcantara®.....	180	Opening and locking vehicle door from inside.....	23
Alloy wheels	178	Unlocking vehicle door with car key	
Fabric linings	180	(remote control).....	21
Headlights, plastic components, adhesive foils...	178	Central locking system	
Leather	179	Functional description	19
Leather care for seats with seat ventilation	179	Centre console	14
Paint	176	Changing car key (remote control) battery.....	209
Safety-belts	180	Changing wheels.....	196
Seals	178	Chassis control systems	
Underbody protection	177	Overview (PSM, PASM, PTV)	134
Use of high-pressure cleaning equipment	175	Chassis number, position	218
Washing the vehicle, instructions	175	Chassis setup	224
Wheel attachment faces.....	198	Functional description	139
Wheel bolts	199	Selecting.....	139
Windows.....	177	Check Engine (emission control)	
Car key (remote control)		Functional description	77
Changing battery.....	209	Warning light	77
Locking vehicle door	22	Checking pressure	198
Unlocking vehicle door.....	21	Child restraint equipment	
Car Telephone	127	Prescribed installation direction	39
Car instructions		Child seat	
Airbags	179	Prescribed installation direction	39
Alcantara®.....	180	Prescribed installation direction	
Alloy wheels.....	178	(dependent on weight of child)	40
		Chrono.....	95
		Cigarette lighter	146
		Closing	25
		Locking vehicle door from inside	23
		Persons/animals remaining in the vehicle	22
		Vehicle door with car key (remote control).....	22
		Closing luggage compartment lid.....	25
		Closing luggage compartment lids	25
		Clutch	
		Manual transmission	132
		Cockpit.....	11
		Adjusting lighting	66
		Cooling system, temperature gauge	100
		Engine oil temperature gauge.....	101
		Fuel gauge	76
		Odometer	76
		Speedometer	76
		Tachometer	76
		Warning and indicator lights, overview.....	74
		Compressor	
		Tire pressure	148
		Control systems	
		Overview (PSM, PASM, PTV)	134
		Coolant	
		Checking level.....	184
		Topping up.....	184
		Cooling system	
		Warning on multi-function display	100
		Cornering light	
		Dynamic	65
		Courtesy lighting, Entry function	65
		Crankcase ventilation	169
		Cruise control	
		Accelerating	125
		Decelerating	125
		Functional description	124
		Interrupting operation	125
		Storing speed	125
		Switching off	126
		Switching on	125
		Cupholder	145
		D	
		Data carrier for vehicle data	218
		Daytime driving lights.....	64
		Defrosting windshield.....	49, 52
		Air-conditioning system	49, 52
		Diagnostic socket	118
		Diagrams	225
		Digital speedometer	76
		Dimensions	224

Dimming		Emergency key	19, 28	Faults	
Adjusting brightness of instrument lighting	66	Emergency operation		Emergency operation of ignition key/control	
Adjusting brightness of interior lighting	67	Filler flap	172	unit in ignition lock	27
Direction indicator, stalk	66	of ignition key/control unit in ignition lock	27	Emergency operation of powerlift tailgate	26
Displacement, Technical data	219	of luggage compartment lid	26	Emergency operation of the filler flap	172
Door		of tailgate	26	Power windows	62
Locking if persons/animals are remaining		Emergency release		When opening and closing	26
in vehicle	22	Front luggage compartment lid	204	Filler flap, emergency operation	172
Locking with car key (remote control)	22	Emergency starting for flat battery	207	Filling capacities	
Malfunctions when opening and closing	26	Emergency starting with jumper cables	207	Coolant	223
Opening and locking from inside	23	Emission control (Check Engine)		Engine oil	223
Unlocking with car key (remote control)	21	Functional description	77	Fuel	223
Door emergency locking	28	Engine		Overview of fluids and fuels	223
Door locking, automatic	22	Break in hints	7	Washer fluid	223
Door opening in an emergency situation	22	Checking oil level	165	Filter	
Drinks holder	145	Cooling system	100	Air cleaner, maintenance instructions	186
Drive		Oil-level gauge	82	Particle filter, maintenance instructions	186
The vehicle cannot be unlocked	26	Starting	119	Fire extinguisher, storage location	216
Driver's door emergency locking	28	Stopping	120	Floor mats, care instructions	179
Driving		Technical data	219	Fluids and fuels	
In Sport mode	3	Topping up oil	166	Coolant	223
On the race circuit	3	Engine drag torque control (MSR)		Engine oil	223
Driving light assistant		Functional description	136	Fuel	223
Daytime driving lights	64	Engine oil	165	Washer fluid	223
Dynamic cornering light	65	Change quantity	223	Folding the seat backrest forward	32, 33
Low beam	64	Checking level	165	Footbrake	
Switching on	64	Consumption	219	Safety notes	121
Driving off		Engine oil pressure	109	Front luggage compartment lid	
Automatic parking brake release upon		Filler opening	167	Emergency release	204
driving off	121	General information	165, 166	Fuel	
Driving performance, Technical data	224	Oil-level warning on the multi-function display	165	Economy	170
DVD		Pressure gauge	101	Evaporation control	174
Installation location	128	Temperature gauge	101	Fuel can	173
Navigation	128	Entry function, courtesy lighting when entering the		Fuel gauge	76
Player	128	vehicle	65	Fuel reserve warning	76, 79
Dynamic cornering light	65	Error messages		Fuels containing ethanol	173
Dynamic Engine Mounting (PADM)	140	Overview	109	Octane rating	171
E		Exhaust pipes	4	Portable fuel containers	4
Electric parking brake		Exhaust system		Quality	171
Automatic parking brake release upon		Sport	141	Recommendation	173
driving off	120	Exterior mirror		Refueling	171
Emergency braking function	120	Adjusting	44	Tank capacity	223
Operating	120	Exterior mirror heating		Fuel can	173
Releasing	120	Switching on/off	59	Fuel container	173
Testing on brake test stand	164, 183	External audio source, interface	128	Fuel containers, portable	4
Warning light	120	F		Fuel gauge	76
Electrical System		Fabric linings (care instructions)	180	Fuel level indicator	
Emergency unlocking, front luggage		Fault reporting		Fuel gauge	76
compartment lid	204	Overview	109	Fuel reserve	172
Emergency flasher	67			Fuse, changing electric fuses	201

G			
Garage door opener		Immobilizer	
Deleting programed signals	155	Functional description	160
Functional description	154	Switching on/off	160
Operating	155	Inclination sensor	
Programing signal (changeable code system)	156	Function indication	160
Programing signal (fixed code system)	155	Switching off with vehicle key (remote control) ...	159
Gear display		Information messages	
Manual transmission	133	Overview	109
PDK transmission/manual transmission	76	Instrument cluster	
Gear shift assist	97	Adjusting lighting	66
G-forces display	98	Cooling system, temperature gauge	100
Glove box		Engine oil temperature gauge	101
Locking	143	Fuel gauge	76
Opening	143	Odometer	76
Ground clearance	4	Speedometer	76
		Tachometer	76
H		Warning and indicator lights, overview	74
Handbrake (electric parking brake)		Instrument lighting	66
Operating	120	Instrument panel	12
Releasing	121	Adjusting lighting	66
Head restraints	31	Cooling system, temperature gauge	100
Headlights		Engine oil temperature gauge	101
Adjusting	212	Fuel gauge	76
Care instructions	178	Odometer	76
Installing	211	Speedometer	76
Notes	210	Tachometer	76
Operating washer system	71	Warning and indicator lights, overview	74
Removing	211	Interior lighting	
Heated rear window		Ambient lighting	68
Switching on/off	59	Interior lights	67
Heating and ventilation		Orientation lighting	68
Setting air distribution	50	Interior lights	67
High-beam headlight	66	Interior mirror	
Stalk	66	Adjusting	45
High-pressure cleaning equipment		Switching automatic anti-dazzle function on/off	46
Instructions for use	175	Interior surveillance	160
Homelink® (garage door opener)		Switching off with vehicle key (remote control) ...	159
Deleting programed signals	155	iPod® interface, installation position	128
Functional description	154		
Operating	155	J	
Programing signal (changeable code system)	156	Jump-lead starting, external power supply	207
Programing signal (fixed code system)	155		
Hot exhaust pipes	4	K	
		Key	
I		Changing battery	209
Identification number, position	218	Emergency operation, ignition lock	27
Ignition lock		Locking vehicle door	22
Emergency operation of the key	27	Removing emergency key	19, 28
Functional description	118	Replacement keys	18
		Unlocking vehicle door	21
		Keys	18
		L	
		LATCH system	
		Prescribed installation direction of child seat (dependent on weight of child)	40
		Lateral acceleration forces	
		Display	98
		Leather, care instructions	179
		Seats with seat ventilation	179
		Lids	
		Emergency unlocking, front luggage compartment lid	204
		Light	
		Headlight flasher	66
		Switching on courtesy lighting when entering the vehicle	65
		Switching on Welcome Home function	65
		Light switch	
		AUTO function	64
		Overview	64
		Lights	
		Bulb chart	210
		Care instructions	178
		Replacing bulbs	210
		Switching interior lights on/off automatically	68
		Switching on when entering the vehicle	65
		Switching on when leaving the vehicle	65
		Loading information	151
		Locking	
		Locking vehicle door from inside	23
		Locking vehicle door with car key (remote control)	22
		Persons/animals remaining in the vehicle	22
		Vehicle door with car key (remote control)	22
		Longitudinal acceleration forces	
		Display	98
		Luggage compartment	29
		Opening	25
		Overview	148, 150
		Luggage cover	150
		M	
		Maintenance work	
		Adding washer fluid	167
		Changing Air Cleaner	186
		Changing Particle Filter	186
		Checking engine oil level	165
		Checking the Coolant Level and Adding Coolant ..	184
		Notes on maintenance	162, 182

Topping up engine oil.....	166	Odometer		Operating	120
Malfunctions		Display	76	Releasing	120
Emergency operation of ignition key in ignition lock	27	Resetting	76	Testing on brake test stand.....	164, 183
Emergency operation of luggage compartment lid	26	Off delay		Particle filter, maintenance instructions	186
Emergency operation of tailgate.....	26	Switching on	65	PASM (Porsche Active Suspension Management)	
Power windows.....	62	Oil	165	Functional description.....	139
Storing end position of the windows	62	Change quantity	223	Overview	134
When opening and closing	26	Checking level	82, 165	Selecting chassis setup	139
Manual air conditioning	51	Consumption	7	Warning message on the multi-function display ..	140
Maximum permitted engine speed		General information	165, 166	PASS AIR BAG OFF	
Manual transmission.....	133	Level gauge	82	Warning light in the center console	39
Minor repairs		Oil pressure	109	Passenger airbag	
In the event of a flat tire.....	199	Oil-level warning on the multi-function display	165	Automatic deactivation of the passenger airbag ...	38
Mirrors		Pressure gauge, oil pressure	101	Warning light in the center console	39
Adjusting exterior mirrors	44	Temperature gauge	101	Passenger mirror	
Exterior mirror heating	59	Topping up	166	Adjusting	44
Switching automatic anti-dazzle function on and off	46	On-board computer		Passenger's door emergency locking, Emergency operation	
Vanity mirror	47	Measuring oil level	82	Driver's door, Passenger's door.....	28
Motion sensor (interior surveillance)		Menu overview	80	PCCB (Porsche Ceramic Composite Brake)	
Switching off with vehicle key (remote control)....	159	Multi-function display	78	General information.....	4, 5
Multi-function display		Operating principle	78	PCM (Porsche Communication Management)	128
Activating functions, opening menus and viewing options.....	79	Performance display	98	Performance display	
Browsing through long lists.....	79	Tire Pressure Monitoring System	86	Power	98
Checking oil level	82	Opening and closing		Torque.....	98
Display areas	79	Brief overview	20	Performance tests on roller-type test stands.....	164, 183
Menu overview	80	Locking vehicle door with car key (remote control).....	22	Performance, Technical data	219
Operating navigation system	85	Opening and locking vehicle door from inside	23	Petrol	
Operating principle	78	Unlocking vehicle door with car key (remote control).....	21	Fuel gauge	76
Performance display	98	Opening and locking		Fuel reserve warning	76, 79
Retrieving vehicle information.....	81	The vehicle cannot be unlocked	26	Octane rating	171
Selecting a radio station	83	Operating in other countries	170	Portable fuel container	173
Sport Chrono	96	Orientation lighting	68	Portable fuel containers.....	4
Tire Pressure Monitoring System	86	Oxygen sensor	169	Quality.....	171
Tire pressure warnings	90, 93	P		Refueling	171
Trip information.....	86	PADM, Dynamic Engine Mounting	140	Tank capacity.....	223
Using the phone.....	84	Paint		Plastic components, care instructions	178
Warning messages.....	109	Care instructions	176	Porsche Active Suspension Management (PASM)	
N		Polishing	176	Functional description.....	139
Navigation system	128	Preserving	176	Overview	134
Using via multi-function display	85	Removing spots and stains.....	176	Warning message on the multi-function display ...	140
O		Repairing damage	176	Porsche Ceramic Composite Brake (PCCB)	
Octane rating	173	Panic button	18	General information.....	4, 5
Octane rating, petrol.....	171	Parking		Porsche Communication Management (PCM)	128
		Applying the parking brake	120	Porsche Dynamic Light System (PDS).....	65
		Locking the vehicle	22	Porsche Entry & Drive	
		Parking brake		Inclination sensor	160
		Automatic parking brake release upon driving off.....	121	Interior surveillance	160
				Porsche Stability Management (PSM)	
				Functional description.....	135
				Multi-function light in the tachometer.....	138

Overview	134
Switching off.....	136
Porsche Torque Vectoring (PTV)	
Functional description.....	140
Overview	134
Portable fuel container.....	173
Power	
Display on the multi-function display	98
Power Steering	186
Power windows	
Adjusting after connecting battery	62
Malfunctions	62
Opening/closing windows with switch	61
Overview of driver's door control panel	61
Overview of passenger's door control panel	61
Storing end position	62
Pressure	
Tires (bar/psi).....	221
Protection against towing (inclination sensor)	
Switching off with vehicle key (remote control).....	159
PSM (Porsche Stability Management)	
Functional description.....	135
Multi-function light in the tachometer	138
Overview	134
Switching off.....	136
Warning light on the multi-function display	207
PTV (Porsche Torque Vectoring)	
Overview	134
R	
Race circuit.....	3
Racing Tires	1, 3
Radio	
Tips	126
Radio remote control	18
Rain sensor	
Adjusting	71
Switching on.....	70
Range on remaining fuel.....	102
Rear	150
Rear fog light	
Adjusting the driving light	65
Switching on.....	64
Rear Luggage Compartment	150
Rear-axle load	151
Refueling.....	172
Relays	
Replacing	201
Remote control.....	18
Changing battery in car key.....	209
Locking vehicle door	22
Unlocking vehicle door	21
Replacement keys.....	18
Restraint system for children	
Prescribed installation direction	39
Restraint systems for children	
Prescribed installation direction	
(dependent on weight of child)	40
Roof load	222
Running in	
Tires.....	7
S	
Safety compliance sticker.....	218
Safety-belts	33
Care instructions	180
Fastening	34
Opening belt buckle	35
Safety-belt pretensioners, functional description	34
Warning light on the tachometer	34
Sealant/sealing set for defective tires.....	199
Seals, care instructions	178
Seat	
Adjusting.....	31
Seat belts.....	33
Seat heating	
Switching off	33
Switching on	33
Seat-belt pretensioner	
Functional description	34
Seats	
Adjusting seat position	31
Adjusting the seat	31
Child restraint system	39
Head restraints.....	31
Seat adjustment	31
Security wheel bolts	
Storage	148
Setting air quantity	
Air-conditioning system	50, 53, 57
Setting automatic air-recirculation mode	
Air-conditioning system	57
Setting fan	
Air-conditioning system	50, 53, 57
Setting temperature	
Air-conditioning system	50, 53, 57
Setting the date	105
Setting the time	105
Settings	
Adjusting on multi-function display	99
Shifting gears	
Gear shift assist.....	97
Manual transmission	132
Shift prompt	76
Side lights	
Switching on.....	64
Slicks	1
Snow chains	
General information	193
Snow tires.....	192
Socket (12 V).....	147
Speed code letter on tire.....	194
Speed control (cruise control)	
Accelerating	125
Decelerating	125
Functional description.....	124
Interrupting operation	125
Storing speed	125
Switching off.....	126
Switching on.....	125
Speed limit.....	194
Speedometer	76
Sport Chrono	95
Sport mode.....	3
Switching on/off.....	141
Sport tires	3
Sports exhaust system	141
Stainless steel tailpipes	
Care instructions	178
Starting	
Engine.....	119
Steam-jet cleaners, instructions for use	175
Steering.....	186
Steering wheel	
Adjustment	46
Stopping	
Engine.....	120
Stopwatch	95
Storage	
Glove box	143
Oddments tray behind the seats	144
Opening storage compartment in armrest.....	144
Storage options	143
Storage compartment	
behind the seats	144
Glove box	143
In armrest, opening	144
Storage	143
Storing the end position for the power windows	62

Summer tires	
Changing tires	197
Storage	192
Sun visor	47
Switching automatic anti-dazzle function on and off	46
Switching emergency flasher on/off	67
Switching on air-recirculation mode	
Air-conditioning system	49, 53, 56
Switching on parking light	66
T	
Tachometer	
Display	76
Tailpipes	
Stainless steel, care instructions	178
Tank	
Ventilation system	174
Technical data	
Driving performance	224
Engine	219
Tire pressure (bar/psi)	221
Tires, wheels	220
Weights, Roof load	222
Technical modifications to the vehicle, information	163
Telephone	127
Using via multi-function display	84
Test stands	
Brake test	164, 183
Performance test	164, 183
Theft protection	17, 160
Tire	
Care	190
Life	190
Traction	189
Wear	190
Tire filling compressor	148
Tire pressure	
Air pressure (bar/psi)	221
Current settings	89
Data (bar/psi)	221
Fill info	88
Speed warning	94
System learning	90
Tire pressure plate	218
Warnings	90, 93
Tire Pressure Monitoring System	
Warning light	87
Tire Pressure Monitoring System (TPMS)	86
Race circuit mode	91
Tire pressure plate	218
Tire sealing compound/sealing set for defective tires	199

Tires	
Breaking in new tires	7
Changing	197
Checking pressure	198
Damage	190
Fixing a flat tire	199
General information	186
Inscription on radial tire	194
Replacing	191
Sealant	199
Setting type and size	89
Sidewall	194
Snow chains (general information)	193
Snow tires (general information)	192
Sport	3
Storage	192
Tire pressure plate	218
Tire pressure, data (bar/psi)	221
Valves	191
Tool kit	148
Tools	148
Top Tether	
Fastening	43
Installing a child seat	43
Top tether	44
Torque	98
Display on the multi-function display	98
Torque display	98
Torque, Technical data	219
Towing lug	
In the tool kit	148
TPMS (Tire Pressure Monitoring System)	86
Race circuit mode	91
Transmission	
Manual transmission	132
Transmission and chassis control systems	
Overview (PSM, PASM, PTV)	134
Transport (on car trains, ferries, etc.)	
Securing the vehicle	215
Switching off inclination sensor	159
Trip counter	
Display	76
Resetting	76
Trip information	86
Trunk entrapment	29
Turn signal, stalk	66

U	
Underbody protection, care instructions	177
Universal audio interface, installation position	128
Unlocking	
Opening vehicle door from inside	23
The vehicle cannot be unlocked	26
Unlocking and opening tailgate	25
Unlocking vehicle door from inside	23
Unlocking vehicle door with car key (remote control)	21
Upshift prompt	76
USB interface, installation position	128
V	
Vanity mirror	47
Vehicle	
Keys	18
Vehicle data	218
Vehicle door	
Locking from inside	23
Locking with car key (remote control)	22
Malfunctions when opening and closing	26
Unlocking with car key (remote control)	21
Vehicle information	
Retrieving on multi-function display	81
Vehicle key (remote control)	
Emergency operation of key/control unit in ignition lock	27
Vehicle settings	
Adapting multi-function display	99
Adjusting on multi-function display	99
Adjusting volume of warning and information tones	108
Air-conditioning settings	104
Changing the language	108
Light and visibility settings	102
Locking settings	104
Resetting to factory settings	99
Selecting settings menu	99
Setting date and time	105
Setting units	107
Vents	
Adjusting	59
Opening/closing	59
Voice control	129

W

Warning messages		Windshield wiper/washer stalk	
Overview	109	Adjusting the rain sensor sensitivity	69
Tire pressure	94	Windshield wiper/washer system	70
Washer fluid		Windshield, fast wiping	70
Antifreeze	167	Windshield, slow wiping	70
Filling capacity	223	Wiping windshield once (one-touch operation)	70
Topping up	167	Windshield wipers	
Washing the vehicle, instructions	175	Care instructions	177
Weights		Stalk	70
Definitions	151	Winter driving	206
Weights, Technical data	222	Winter tires	
Welcome Home function		Changing tires	197
Switching on	65	General information	192
Wheel		Storage	192
Attachment faces	198	Wiper blades	
Checking pressure	198	Care instructions	177
Security wheel bolts	148	Replacing	168
Wheel alignment	191	Wrench socket for security wheel bolt	
Wheel attachment faces	198	Using	199
Wheel change	193		
Wheels			
Adjusting	191		
Changing	196		
Fixing a flat tire	199		
General information	186		
Inscription on alloy wheels	195		
Inscription on radial tire	194		
Overview	220		
Replacing tires (general information)	191		
Rim offset	220		
Security wheel bolt (wrench socket)	199		
Size	220		
Snow chains (general information)	193		
Snow tires (general information)	192		
Storage	192		
Tire pressure plate	218		
Tire pressure, data (bar/psi)	221		
Tire sealant	199		
Wheel attachment faces	198		
Wheel balancing	191		
Wheel bolts (care instructions)	199		
Windows			
Adjusting after connecting battery	62		
Care instructions	177		
Opening/closing with switch	61		
Storing end position	62		
Windshield washer system			
Adding washer fluid	167		
Antifreeze	167		
Filling capacity	223		